

O6S314

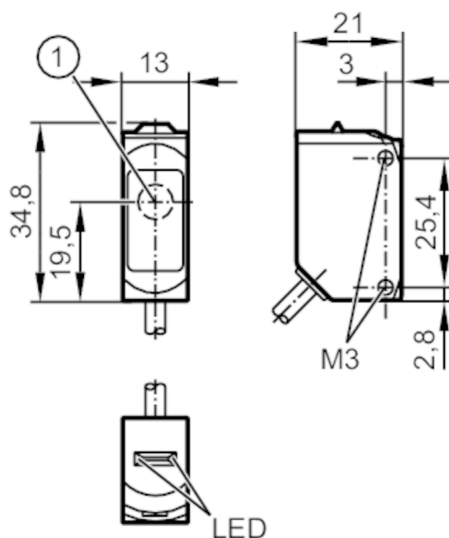

Through-beam sensor transmitter

O6S-OOKG/0,30M/US



1: light emission



Product characteristics

Type of light	red light
Communication interface	IO-Link
Housing	rectangular
Dimensions [mm]	34.8 x 13 x 21

Application

Function principle	Through-beam sensor
--------------------	---------------------

Electrical data

Operating voltage [V]	10...30 DC
Current consumption [mA]	11; ((24 V))
Protection class	III
Type of light	red light
Wave length [nm]	633

Detection zone

Transmitter / receiver	transmitter
Range [m]	< 10
Max. light spot diameter [mm]	300
Light spot dimensions refer to	at maximum range

O6S314



Through-beam sensor transmitter

O6S-OOKG/0,30M/US

Interfaces		
Communication interface	IO-Link	
Transmission type	COM 2 (38,4 kBaud)	
IO-Link revision	1.1	
SDCI standard	IEC 61131-9 CDV	
IO-Link device ID	420 d / 00 01 A4 h	
Profiles	Smart Sensor: Device Identification	
SIO mode	yes	
Required master port type	A	
Operating conditions		
Ambient temperature [°C]	-25...80	
Protection	IP 65; IP 67; IP 68; IP 69K	
Tests / approvals		
EMC	EN 60947-5-2	
Mechanical data		
Weight [g]	52.6	
Housing	rectangular	
Dimensions [mm]	34.8 x 13 x 21	
Materials	housing: stainless steel (1.4404 / 316L); plastics: PPSU; Sealing: EPDM	
Lens material	PMMA	
Lens alignment	side lens	
Displays / operating elements		
Display	operation	1 x LED, green
Remarks		
Pack quantity	1 pcs.	
Electrical connection		
Cable: 0.3 m, PVC; 3 x 0.25 mm ²		
Connector: 1 x M12		
		

Through-beam sensor transmitter

O6S-OOKG/0,30M/US

Connection

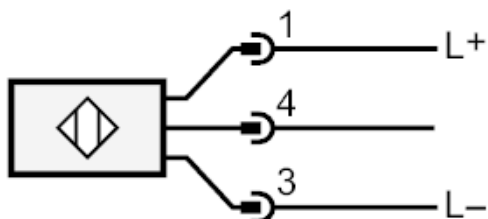

4 IO-Link

Diagrams and graphs

excess gain graph

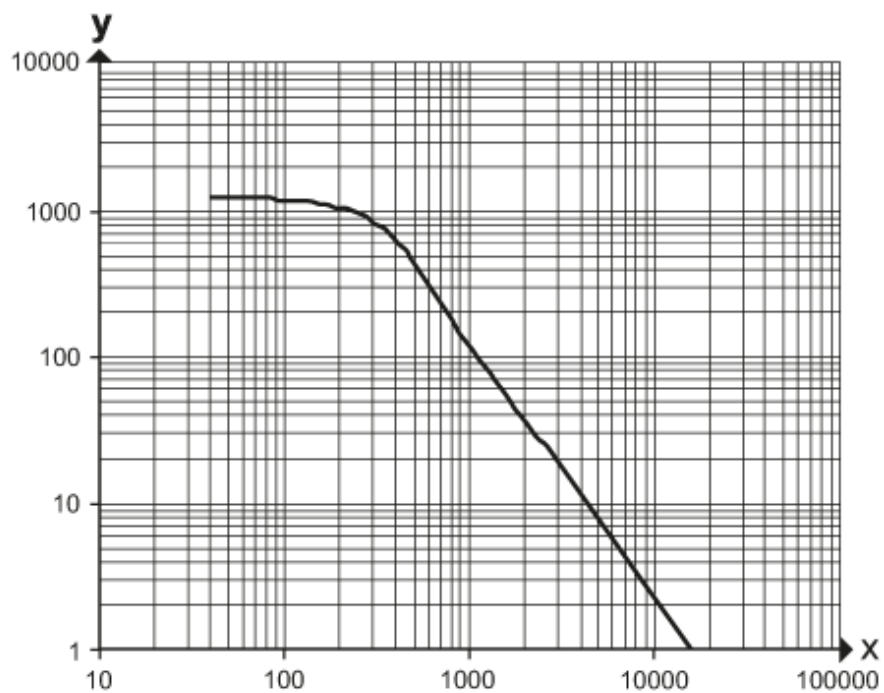

x: distance [mm]

y: excess gain factor