



# PRODUCT/PROCESS CHANGE NOTIFICATION

---

PCN IPD-DIS/13/7900  
Dated 03 Jul 2013

---

**Qualification of copper wire for SOT23 and SOT323 at  
ST's subcontractor in Malaysia and Design optimization  
and new leadframe layout for DVIULC6-4SC6**

**Table 1. Change Implementation Schedule**

Forecasted implementation date for change	26-Jun-2013
Forecasted availability date of samples for customer	26-Jun-2013
Forecasted date for <b>STMicroelectronics</b> change Qualification Plan results availability	26-Jun-2013
Estimated date of changed product first shipment	02-Oct-2013

**Table 2. Change Identification**

Product Identification (Product Family/Commercial Product)	SOT23 and SOT323 packages
Type of change	Package assembly material change
Reason for change	to optimize our industrial process and material
Description of the change	see drawing in attached
Change Product Identification	QA number, internal codification and date code
Manufacturing Location(s)	

**Table 3. List of Attachments**

Customer Part numbers list	
Qualification Plan results	

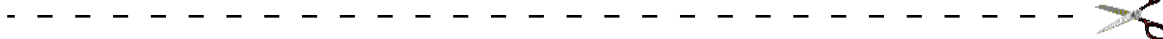

Customer Acknowledgement of Receipt		<b>PCN IPD-DIS/13/7900</b>
Please sign and return to STMicroelectronics Sales Office		<b>Dated 03 Jul 2013</b>
<input type="checkbox"/> Qualification Plan Denied <input type="checkbox"/> Qualification Plan Approved  <input type="checkbox"/> Change Denied <input type="checkbox"/> Change Approved	Name: Title: Company: Date: Signature:	
Remark ..... ..... ..... ..... ..... ..... ..... ..... ..... .....		

## DOCUMENT APPROVAL

Name	Function
Paris, Eric	Marketing Manager
Nopper, Christian	Product Manager
Cazaubon, Guy	Q.A. Manager

## PCN Product/Process Change Notification

**Change 1:** Qualification of copper wire for SOT23 and SOT323 at ST's subcontractor in Malaysia

**Change 2:** Design optimization and new leadframe layout for DVIULC6-4SC6 and HDMIULC6-4SC6

<b>Notification number:</b>	IPD-DIS/13/7900	<b>Issue Date</b>	24/06/2013
-----------------------------	-----------------	-------------------	------------

<b>Issued by</b>	Aline AUGIS
------------------	-------------

<b>Product series affected by the change</b>	<p><b>Protection</b>          DALC208SC6          DSILC6-4SC6          DSL01xxxx          DSL02xxxx          DSL03xxxx          DSL04xxxx          DVIULC6-4SC6          ESDA25SC6-BOS          ESDAxx-2SC6          ESDAxx-4BC6          ESDAxx-5SC6          ESDAxx-5W6          ESDAxxBC6          ESDAxxL          ESDAxxSC5          ESDAxxSC5S          ESDAxxSC6          ESDAxxW          ESDAxxW5          ESDAxxW5S          HDMIULC6-4SC6          LBP01-0803SC5          USBxx-2SC6          USBxx-4SC6</p> <p><b>IPADs</b>          EMIF01-10005W5          KBMF01SC6          USBDF01W5          USBDF02W5          USBUF01W6          USBUF02W6</p> <p><b>ACSwitches</b>          SMDB3</p>
--	--

<b>Type of change</b>	<p><a href="#">Change 1:</a> package assembly material change</p> <p><a href="#">Change 2:</a> waferfab material change and package assembly material change</p>
-----------------------	--

(1) IPD: Industrial & Power Discretes - ASD: Application Specific Device – IPAD™: Integrated Passive and Active Devices

**Description of the change**

**Change 1: copper wire bonding**

		Before Change	After Change		
Package	Wire	Au 0.8mils, 1mils or 1.3mils	Cu 0.8mils	Package	After Change Dual pad frame Au wire
				Before Change	Single pad frame Cu wire
<b>All SOT23-323 packages</b>				<b>DVIULC6-4SC6 and HDMIULC6-4SC6</b>	

**Change 2: new leadframe for DVIULC6-4SC6 and HDMIULC6-4SC6**

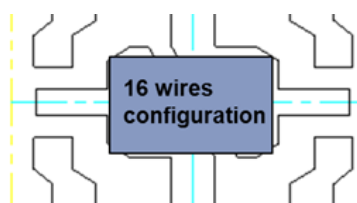

BEFORE CHANGE

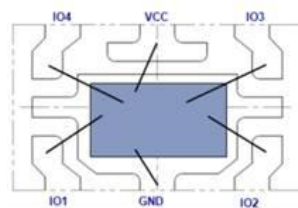

AFTER CHANGE

**Reason for change**

**Change 1:** The change is performed in order to optimize our industrial process and material.  
**Change 2:** The design optimization and the new leadframe layout will simplify the assembly process and enable a better service to our customers.

**Former versus changed product:**

The changed products do not present modified electrical, dimensional or thermal parameters, leaving unchanged the current information published in the product datasheet  
 The Moisture Sensitivity Level of the part (according to the IPC/JEDEC JSTD-020D standard) remains unchanged.  
 The footprint recommended by ST remain the same.  
 There is no change in the packing modes and the standard delivery quantities either.  
 The products remain in full compliance with the ST ECOPACK®2 grade (“halogen-free”).

**Disposition of former products**

Deliveries of former product will continue while the conversion is brought to completion and as long as former product stocks last.

**Marking and traceability**

QA number, date code and internal codification

**Qualification complete date**

Week 16-2013

(1) IPD: Industrial & Power Discretes - ASD: Application Specific Device – IPAD™: Integrated Passive and Active Devices

**Forecasted sample availability**

Product family	Sub-family	Commercial part Number	Availability date
<b>Protection</b>	SOT23/323	DVIULC6-4SC6	From now
		ESDALC6V1W5	Week 32-2013
		HDMIULC6-4SC6	Week 28-2013
		ESDA14V2SC5	Week 28-2013
		ESDA5V3L	Week 28-2013
		ESDA6V1L	Week 28-2013
		USBLC6-2SC6	Week 28-2013
		USBLC6-4SC6	Week 28-2013
		DALC208SC6	Week 28-2013
		DSL01-008SC5	Week 28-2013
		ESDA14V2L	Week 28-2013
		ESDA25L	Week 28-2013
		ESDA5V3SC5	Week 28-2013
		ESDA5V3SC6	Week 28-2013
		ESDA6V1-4BC6	Week 28-2013
ESDA6V1SC5	Week 28-2013		
ESDA6V1W5	Week 28-2013		
<b>ACSwitches</b>	SOT-23	SMDB3	Week 28-2013
<b>IPAD</b>	SOT-323	USBUF02W6	From now

**Change implementation schedule**

Sales types	Estimated production start	Estimated first shipments
<b>All</b>	<b>Week 36-2013</b>	<b>Week 40-2013</b>

**Comments:**

**Customer's feedback**

Please contact your local ST sales representative or quality contact for requests concerning this change notification.  
 Absence of acknowledgement of this PCN within 30 days of receipt will constitute acceptance of the change  
 Absence of additional response within 90 days of receipt of this PCN will constitute acceptance of the change

**Qualification program and results**

QRP13126 (change 2) and QRP13127 (change 1)  
 Attached

## Reliability Report

*Design optimization and new leadframe layout for  
DVIULC6-4SC6 and HDMIULC6-4SC6*

General Information		Locations	
<b>Product Line</b>	<i>Transil ASD</i>	<b>Wafer fab</b>	<i>STMicroelectronics Tours (France)</i>
<b>Product Description</b>	<i>4-line ESD protection for high speed lines</i>	<b>Assembly plant</b>	<i>Subcontractor (Malaysia)</i>
<b>P/N</b>	<i>DVIULC6-4SC6 HDMIULC6-4SC6</i>	<b>Reliability Lab</b>	<i>STMicroelectronics Tours (France)</i>
<b>Product Group</b>	<i>IPD</i>		
<b>Product division</b>	<i>ASD&amp;IPAD</i>		
<b>Package</b>	<i>SOT23-6L</i>		
<b>Silicon Process technology</b>	<i>ULC</i>		
<b>Maturity level step</b>	<i>Qualified</i>		

### DOCUMENT INFORMATION

Version	Date	Pages	Prepared by	Approved by	Comment
1.0	22-APRIL-2013	8	J. MICHELON	J.P. REBRASSE	PCN: IPD-DIS/13/7900

Note: This report is a summary of the reliability trials performed in good faith by STMicroelectronics in order to evaluate the potential reliability risks during the product life using a set of defined test methods.  
 This report does not imply for STMicroelectronics expressly or implicitly any contractual obligations other than as set forth in STMicroelectronics general terms and conditions of Sale. This report and its contents shall not be disclosed to a third party without previous written agreement from STMicroelectronics.



## TABLE OF CONTENTS

<b>1</b>	<b>APPLICABLE AND REFERENCE DOCUMENTS .....</b>	<b>3</b>
<b>2</b>	<b>GLOSSARY .....</b>	<b>3</b>
<b>3</b>	<b>RELIABILITY EVALUATION OVERVIEW .....</b>	<b>3</b>
3.1	OBJECTIVES .....	3
3.2	CONCLUSION .....	3
<b>4</b>	<b>DEVICE CHARACTERISTICS .....</b>	<b>4</b>
4.1	DEVICE DESCRIPTION .....	4
<b>5</b>	<b>TESTS RESULTS SUMMARY .....</b>	<b>4</b>
5.1	TEST VEHICLE .....	4
5.2	TEST PLAN AND RESULTS SUMMARY .....	5
<b>6</b>	<b>ANNEXES .....</b>	<b>5</b>
6.1	DEVICE DETAILS .....	6
6.2	TESTS DESCRIPTION .....	7

## 1 APPLICABLE AND REFERENCE DOCUMENTS

Document reference	Short description
JESD47	Stress-Test-Driven Qualification of Integrated Circuits
SOP 2614	Reliability requirements for product qualification
0061692	Reliability tests and criteria for qualifications
AEC-Q100	Stress test qualification for automotive grade integrated circuits
AEC-Q101	Stress test qualification for automotive grade discrete semiconductors

## 2 GLOSSARY

DUT	Device Under Test
PCB	Printed Circuit Board
SS	Sample Size

## 3 RELIABILITY EVALUATION OVERVIEW

### 3.1 Objectives

To qualify the design optimization and the new leadframe layout of DVIULC6-4SC6 and HDMIUL6-4SC6. The goal of this change will simplify the assembly process and enable a better service to our customers.

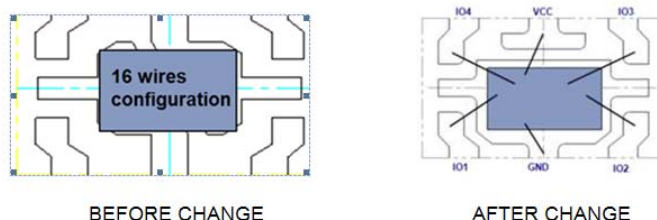

	After Change	Before Change
Package	Dual pad frame Au wire	Single pad frame Cu wire

### 3.2 Conclusion

Qualification plan requirements have been fulfilled without exception. Reliability tests have shown that the devices behave correctly against environmental tests (no failure). Moreover, the stability of electrical parameters during the accelerated tests demonstrates the robustness of the products and safe operation, which is consequently expected during their lifetime.

## 4 DEVICE CHARACTERISTICS

### 4.1 Device description

The **HDMIULC6-4SC6** is a monolithic, application specific discrete device dedicated to ESD protection of the HDMI connection. It also offers the same high level of protection for IEEE 1394a and IEEE 1394b/c, USB 2.0, Ethernet links, and video lines.

Its ultra high cutoff frequency (5.3 GHz) secures a high level of signal integrity. The device topology provides this integrity without compromising the complete protection of ICs against the most stringent ESD strikes.

The **DVIULC6-4SC6** is a monolithic, application specific discrete device dedicated to ESD protection of high speed interfaces, such as DVI, HDMI, IEEE 1394a, and b, USB 2.0, Ethernet links and video lines. Its ultralow line capacitance secures a high level of signal integrity without compromise in protecting sensitive chips against the most stringently characterized ESD strikes.

## 5 TESTS RESULTS SUMMARY

### 5.1 Test vehicle

Lot #	Part Number	Die Manufacturing plant	Assembly plant	Comment
1	DVIULC6-4SC6	STMicroelectronics Tours	Subcontractor Malaysia	New version: design optimization and the new leadframe layout / Cu wire
2	DVIULC6-4SC6	STMicroelectronics Tours	Subcontractor Malaysia	
3	DVIULC6-4SC6	STMicroelectronics Tours	Subcontractor Malaysia	

## 5.2 Test plan and results summary

### DVIULC6-4SC6

Test	PC	Std ref.	Conditions	SS	Steps	Failure/SS			Note
						Lot 1	Lot 2	Lot 3	
<b>Die Oriented Tests</b>									
HTRB	N	JESD22 A-108	Tj = 125°C / VR = 5V	231	168h	0/77	0/77	0/77	
					500h	0/77	0/77	0/77	
					1000h	0/77	0/77	0/77	
<b>package Oriented Tests</b>									
MSL1 search	Y	JESD22 A-113	Ta = 85°C / RH=85%	30	168h			0/30	MSL1 validated
THB	Y	JESD22 A-101	Ta = 85°C; RH = 85% VR = 5V	77	168h			0/77	
					500h			0/77	
					1000h			0/77	
TC	Y	JESD22 A-104	-65°C / +150°C 2 cycles / hour	77	1000 cycles			0/77	
AC	Y	JESD22 A102	Ta =121°C; 100%RH 2 BAR	77	96h			0/77	

## 6 ANNEXES

### 6.1 Devicedetails

#### Pin connection

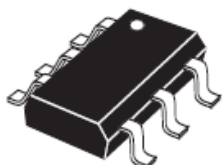

**SOT23-6L  
(JEDEC MO178AB)**

#### Block diagram

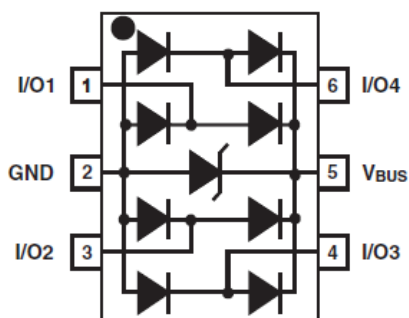

#### Package outline/Mechanical data

Ref.	Dimensions					
	Millimeters			Inches		
	Min.	Typ.	Max.	Min.	Typ.	Max.
A	0.90	-	1.45	0.035	-	0.057
A1	0	-	0.10	0	-	0.004
A2	0.90	-	1.30	0.035	-	0.051
b	0.35	-	0.50	0.014	-	0.020
c	0.09	-	0.20	0.004	-	0.008
D	2.80	-	3.05	0.11	-	0.118
E	1.50	-	1.75	0.059	-	0.069
e	-	0.95	-	-	0.037	-
H	2.60	-	3.00	0.102	-	0.118
L	0.10	-	0.60	0.004	-	0.024
$\theta$	0°	-	10°	0°	-	10°

## 6.2 Tests Description

Test name	Description	Purpose
<b>Die Oriented</b>		
<b>HTRB</b> High Temperature Reverse Bias	The device is stressed in static configuration, trying to satisfy as much as possible the following conditions: low power dissipation; max. supply voltage compatible with diffusion process and internal circuitry limitations;	To determine the effects of bias conditions and temperature on solid state devices over time. It simulates the devices operating condition in an accelerated way. To maximize the electrical field across either reverse-biased junctions or dielectric layers, in order to investigate the failure modes linked to mobile contamination, oxide ageing, layout sensitivity to surface effects.
<b>Package Oriented</b>		
<b>PC</b> Preconditioning	The device is submitted to a typical temperature profile used for surface mounting devices, after controlled moisture absorption.	As stand-alone test: to investigate the moisture sensitivity level. As preconditioning before other reliability tests: to verify that the surface mounting stress does not impact on the subsequent reliability performance. The typical failure modes are "popcorn" effect and delamination.
<b>THB</b> Temperature Humidity Bias	The device is biased in static configuration minimizing its internal power dissipation, and stored at controlled conditions of ambient temperature and relative humidity.	To evaluate the package moisture resistance with electrical field applied, both electrolytic and galvanic corrosion are put in evidence.
<b>TC</b> Temperature Cycling	The device is submitted to cycled temperature excursions, between a hot and a cold chamber in air atmosphere.	To investigate failure modes related to the thermo-mechanical stress induced by the different thermal expansion of the materials interacting in the die-package system. Typical failure modes are linked to metal displacement, dielectric cracking, molding compound delamination, wire-bonds failure, die-attach layer degradation.
<b>AC</b> Autoclave	The device is stored in saturated steam, at fixed and controlled conditions of pressure and temperature.	To investigate corrosion phenomena affecting die or package materials, related to chemical contamination and package hermeticity.

# Reliability Report

## Qualification of copper wire for SOT23 and SOT323 at ST's subcontractor in Malaysia

General Information		Locations	
<b>Product Line</b>	<i>Protection/IPADs/ACSwitches</i>	<b>Wafer fab</b>	<i>STMicroelectronics Tours (France) STMicroelectronics AngMoKio (Singapore)</i>
<b>P/N</b>	<p><b>Protection</b></p> DALC208SC6 DSILC6-4SC6 DSL01xxxx DSL02xxxx DSL03xxxx DSL04xxxx DVIULC6-4SC6 ESDA25SC6-BOS ESDAxx-2SC6 ESDAxx-4BC6 ESDAxx-5SC6 ESDAxx-5W6 ESDAxxBC6 ESDAxxL ESDAxxSC5 ESDAxxSC5S ESDAxxSC6 ESDAxxW ESDAxxW5 ESDAxxW5S HDMIULC6-4SC6 LBP01-0803SC5 USBxx-2SC6 USBxx-4SC6	<b>Assembly plant</b>	<i>Subcontractor (Malaysia)</i>
	<p><b>IPADs</b></p> EMIF01-10005W5 KBMF01SC6 USBDF01W5 USBDF02W5 USBUF01W6 USBUF02W6	<b>Reliability Lab</b>	<i>STMicroelectronics Tours (France)</i>
	<p><b>ACSwitches</b></p> SMDB3		
<b>Product Group</b>	<i>IPD</i>		
<b>Product division</b>	<i>ASD&amp;IPAD</i>		
<b>Package</b>	<i>SOT23/323</i>		
<b>Maturity level step</b>	<i>Qualified</i>		

### DOCUMENT INFORMATION

Version	Date	Pages	Prepared by	Approved by	Comment
1.0	22-APRIL-2013	8	J. MICHELON	J.P. REBRASSE	PCN: IPD-DIS/13/7900

Note: This report is a summary of the reliability trials performed in good faith by STMicroelectronics in order to evaluate the potential reliability risks during the product life using a set of defined test methods.

This report does not imply for STMicroelectronics expressly or implicitly any contractual obligations other than as set forth in STMicroelectronics general terms and conditions of Sale. This report and its contents shall not be disclosed to a third party without previous written agreement from STMicroelectronics.

## TABLE OF CONTENTS

<b>1</b>	<b>APPLICABLE AND REFERENCE DOCUMENTS .....</b>	<b>3</b>
<b>2</b>	<b>GLOSSARY .....</b>	<b>3</b>
<b>3</b>	<b>RELIABILITY EVALUATION OVERVIEW .....</b>	<b>3</b>
3.1	OBJECTIVES .....	3
3.2	CONCLUSION .....	3
<b>4</b>	<b>DEVICE CHARACTERISTICS .....</b>	<b>4</b>
4.1	DEVICE DESCRIPTION .....	4
<b>5</b>	<b>TESTS RESULTS SUMMARY .....</b>	<b>4</b>
5.1	TEST VEHICLE .....	4
5.2	TEST PLAN AND RESULTS SUMMARY .....	5
<b>6</b>	<b>ANNEXES .....</b>	<b>7</b>
6.1	TESTS DESCRIPTION .....	7



## **1 APPLICABLE AND REFERENCE DOCUMENTS**

Document reference	Short description
JESD47	Stress-Test-Driven Qualification of Integrated Circuits
SOP 2614	Reliability requirements for product qualification
0061692	Reliability tests and criteria for qualifications
AEC-Q101	Stress test qualification for automotive grade discrete semiconductors

## **2 GLOSSARY**

DUT	Device Under Test
PCB	Printed Circuit Board
SS	Sample Size

## **3 RELIABILITY EVALUATION OVERVIEW**

### **3.1 Objectives**

To qualify copper wire for SOT23 and SOT323 at ST's subcontractor in Malaysia.

### **3.2 Conclusion**

Qualification plan requirements have been fulfilled without exception. Reliability tests have shown that the devices behave correctly against environmental tests (no failure). Moreover, the stability of electrical parameters during the accelerated tests demonstrates the robustness of the products and safe operation, which is consequently expected during their lifetime.

## **4 DEVICE CHARACTERISTICS**

### **4.1 Change description**

All SOT23-323 packages from ST's subcontractor are included in this change.

		Before Change	After Change
Package	Wire	Au 0.8mils, 1mils or 1.3mils	<b>Cu 0.8mils</b>

## **5 TESTS RESULTS SUMMARY**

### **5.1 Test vehicle**

Lot #	Part Number	Die Manufacturing plant	Assembly plant	Comments
Lot 1	ESDCAN24-2BLY	STMicroelectronics Tours (France)	Subcontractor Malaysia	Qualification Lot
Lot 2	ESDA6V1SC6	STMicroelectronics Tours (France)	Subcontractor Malaysia	Qualification Lot
Lot 3	DSL01-024SC5	STMicroelectronics Tours (France)	Subcontractor Malaysia	Qualification Lot
Lot 4	USBLC6-4SC6	STMicroelectronics AngMoKio (Singapore)	Subcontractor Malaysia	Qualification Lot

## 5.2 Test plan and results summary

### ESDCAN24-2BLY

Test	PC	Std ref.	Conditions	SS	Steps	Failure/SS	Note
						Lot 1	
<b>package Oriented Tests</b>							
THB	Y	JESD22 A-101	Ta = 85°C / RH = 85% VR = 24V	77	168h	0/77	
					504h	0/77	
					1000h	0/77	
TC	Y	JESD22 A-104	[-65°C +150C] / 2 Cycles/hour	77	500C	0/77	
					1000C	0/77	
AC	Y	JESD22 A-102	Ta = 121°C / RH = 100% 2 BARS	77	96h	0/77	

### ESDA6V1SC6

Test	PC	Std ref.	Conditions	SS	Steps	Failure/SS	Note
						Lot 2	
<b>package Oriented Tests</b>							
THB	Y	JESD22 A-101	Ta = 85°C / RH = 85% VR = 24V	77	168h	0/77	
					504h	0/77	
					1000h	0/77	
TC	Y	JESD22 A-104	[-65°C +150C] / 2 Cycles/hour	77	500C	0/77	
					1000C	0/77	
AC	Y	JESD22 A-102	Ta = 121°C / RH = 100% 2 BARS	77	96h	0/77	

### DSL01-024SC5

Test	PC	Std ref.	Conditions	SS	Steps	Failure/SS	Note
						Lot 3	
<b>package Oriented Tests</b>							
THB	Y	JESD22 A-101	Ta = 85°C / RH = 85% VR = 24V	77	168h	0/77	
					504h	0/77	
					1000h	0/77	
TC	Y	JESD22 A-104	[-65°C +150C] / 2 Cycles/hour	77	500C	0/77	
					1000C	0/77	
AC	Y	JESD22 A-102	Ta = 121°C / RH = 100% 2 BARS	77	96h	0/77	

**USBLC6-4SC6**

Test	PC	Std ref.	Conditions	SS	Steps	Failure/SS	Note
						Lot 4	
<b>Package Oriented Tests</b>							
THB	Y	JESD22 A-101	Ta = 85°C / RH = 85% VR = 24V	77	168h	0/77	
					504h	0/77	
					1000h	0/77	
TC	Y	JESD22 A-104	[-65°C +150C] / 2 Cycles/hour	77	500C	0/77	
					1000C	0/77	
AC	Y	JESD22 A-102	Ta = 121°C / RH = 100% 2 BARS	77	96h	0/77	
HTS	N	JESD22 A-103	Ta = 150°C	77	168h	0/77	
					504h	0/77	
					1000h	0/77	
					2000h	0/77	

## 6 ANNEXES

### 6.1 Tests Description

Test name	Description	Purpose
<b>Die Oriented</b>		
<b>HTRB</b> High Temperature Reverse Bias	The device is stressed in static configuration, trying to satisfy as much as possible the following conditions: low power dissipation;  max. supply voltage compatible with diffusion process and internal circuitry limitations;	To determine the effects of bias conditions and temperature on solid state devices over time. It simulates the devices operating condition in an accelerated way. To maximize the electrical field across either reverse-biased junctions or dielectric layers, in order to investigate the failure modes linked to mobile contamination, oxide ageing, layout sensitivity to surface effects.
<b>Package Oriented</b>		
<b>PC</b> Preconditioning	The device is submitted to a typical temperature profile used for surface mounting devices, after controlled moisture absorption.	As stand-alone test: to investigate the moisture sensitivity level. As preconditioning before other reliability tests: to verify that the surface mounting stress does not impact on the subsequent reliability performance. The typical failure modes are "popcorn" effect and delamination.
<b>THB</b> Temperature Humidity Bias	The device is biased in static configuration minimizing its internal power dissipation, and stored at controlled conditions of ambient temperature and relative humidity.	To evaluate the package moisture resistance with electrical field applied, both electrolytic and galvanic corrosion are put in evidence.
<b>TC</b> Temperature Cycling	The device is submitted to cycled temperature excursions, between a hot and a cold chamber in air atmosphere.	To investigate failure modes related to the thermo-mechanical stress induced by the different thermal expansion of the materials interacting in the die-package system. Typical failure modes are linked to metal displacement, dielectric cracking, molding compound delamination, wire-bonds failure, die-attach layer degradation.
<b>AC</b> Autoclave	The device is stored in saturated steam, at fixed and controlled conditions of pressure and temperature.	To investigate corrosion phenomena affecting die or package materials, related to chemical contamination and package hermeticity.

**Please Read Carefully:**

Information in this document is provided solely in connection with ST products. STMicroelectronics NV and its subsidiaries ("ST") reserve the right to make changes, corrections, modifications or improvements, to this document, and the products and services described herein at any time, without notice.

All ST products are sold pursuant to ST's terms and conditions of sale.

Purchasers are solely responsible for the choice, selection and use of the ST products and services described herein, and ST assumes no liability whatsoever relating to the choice, selection or use of the ST products and services described herein.

No license, express or implied, by estoppel or otherwise, to any intellectual property rights is granted under this document. If any part of this document refers to any third party products or services it shall not be deemed a license grant by ST for the use of such third party products or services, or any intellectual property contained therein or considered as a warranty covering the use in any manner whatsoever of such third party products or services or any intellectual property contained therein.

**UNLESS OTHERWISE SET FORTH IN ST'S TERMS AND CONDITIONS OF SALE ST DISCLAIMS ANY EXPRESS OR IMPLIED WARRANTY WITH RESPECT TO THE USE AND/OR SALE OF ST PRODUCTS INCLUDING WITHOUT LIMITATION IMPLIED WARRANTIES OF MERCHANTABILITY, FITNESS FOR A PARTICULAR PURPOSE ( AND THEIR EQUIVALENTS UNDER THE LAWS OF ANY JURISDICTION ), OR INFRINGEMENT OF ANY PATENT, COPYRIGHT OR OTHER INTELLECTUAL PROPERTY RIGHT.**

**UNLESS EXPRESSLY APPROVED IN WRITING BY TWO AUTHORIZED ST REPRESENTATIVES, ST PRODUCTS ARE NOT RECOMMENDED, AUTHORIZED OR WARRANTED FOR USE IN MILITARY, AIR CRAFT, SPACE, LIFE SAVING, OR LIFE SUSTAINING APPLICATIONS, NOR IN PRODUCTS OR SYSTEMS WHERE FAILURE OR MALFUNCTION MAY RESULT IN PERSONAL INJURY, DEATH, OR SEVERE PROPERTY OR ENVIRONMENTAL DAMAGE. ST PRODUCTS WHICH ARE NOT SPECIFIED AS "AUTOMOTIVE GRADE" MAY ONLY BE USED IN AUTOMOTIVE APPLICATIONS AT USER'S OWN RISK.**

Resale of ST products with provisions different from the statements and/or technical features set forth in this document shall immediately void any warranty granted by ST for the ST product or service described herein and shall not create or extend in any manner whatsoever, any liability of ST.

ST and the ST logo are trademarks or registered trademarks of ST in various countries.

Information in this document supersedes and replaces all information previously supplied.

The ST logo is a registered trademark of STMicroelectronics. All other names are the property of their respective owners

©2013 STMicroelectronics - All rights reserved.

STMicroelectronics group of companies

Australia - Belgium - Brazil - Canada - China - Czech Republic - Finland - France - Germany - Hong Kong - India - Israel - Italy - Japan -  
Malaysia - Malta - Morocco - Philippines - Singapore - Spain - Sweden - Switzerland - United Kingdom - United States of America

[www.st.com](http://www.st.com)





## Public Products List

PCN Title : Qualification of copper wire for SOT23 and SOT323 at ST's subcontractor in Malaysia and Design optimization and new leadframe la  
PCN Reference : IPD-DIS/13/7900  
PCN Created on : 01-JUL-2013

Subject : Public Products List

Dear Customer,

Please find below the Standard Public Products List impacted by the change:

### ST COMMERCIAL PRODUCT

DALC208SC6	DSL01-008SC5	DSL01-010SC5
DSL01-016SC5	DSL01-024SC5	DSL02-005SC5
DSL02-008SC5	DSL02-010SC5	DVIULC6-4SC6
EMIF01-10005W5	ESDA14V2L	ESDA14V2SC5
ESDA14V2SC6	ESDA17-5SC6	ESDA19SC6
ESDA25L	ESDA25SC6	ESDA25W
ESDA25W5	ESDA5V3L	ESDA5V3SC5
ESDA5V3SC6	ESDA6V1-4BC6	ESDA6V1-5SC6
ESDA6V1-5W6	ESDA6V1BC6	ESDA6V1L
ESDA6V1SC5	ESDA6V1SC6	ESDA6V1W5
ESDALC6V1W5	ESDALCL6-2SC6	HDMIULC6-4SC6
KBMF01SC6	LBP01-0803SC5	SMDB3
USBDF01W5	USBDF02W5	USBLC6-2SC6
USBLC6-4SC6	USBUF01W6	USBUF02W6

**Please Read Carefully:**

Information in this document is provided solely in connection with ST products. STMicroelectronics NV and its subsidiaries ("ST") reserve the right to make changes, corrections, modifications or improvements, to this document, and the products and services described herein at any time, without notice.

All ST products are sold pursuant to ST's terms and conditions of sale.

Purchasers are solely responsible for the choice, selection and use of the ST products and services described herein, and ST assumes no liability whatsoever relating to the choice, selection or use of the ST products and services described herein.

No license, express or implied, by estoppel or otherwise, to any intellectual property rights is granted under this document. If any part of this document refers to any third party products or services it shall not be deemed a license grant by ST for the use of such third party products or services, or any intellectual property contained therein or considered as a warranty covering the use in any manner whatsoever of such third party products or services or any intellectual property contained therein.

**UNLESS OTHERWISE SET FORTH IN ST'S TERMS AND CONDITIONS OF SALE ST DISCLAIMS ANY EXPRESS OR IMPLIED WARRANTY WITH RESPECT TO THE USE AND/OR SALE OF ST PRODUCTS INCLUDING WITHOUT LIMITATION IMPLIED WARRANTIES OF MERCHANTABILITY, FITNESS FOR A PARTICULAR PURPOSE ( AND THEIR EQUIVALENTS UNDER THE LAWS OF ANY JURISDICTION ), OR INFRINGEMENT OF ANY PATENT, COPYRIGHT OR OTHER INTELLECTUAL PROPERTY RIGHT.**

**UNLESS EXPRESSLY APPROVED IN WRITING BY TWO AUTHORIZED ST REPRESENTATIVES, ST PRODUCTS ARE NOT RECOMMENDED, AUTHORIZED OR WARRANTED FOR USE IN MILITARY, AIR CRAFT, SPACE, LIFE SAVING, OR LIFE SUSTAINING APPLICATIONS, NOR IN PRODUCTS OR SYSTEMS WHERE FAILURE OR MALFUNCTION MAY RESULT IN PERSONAL INJURY, DEATH, OR SEVERE PROPERTY OR ENVIRONMENTAL DAMAGE. ST PRODUCTS WHICH ARE NOT SPECIFIED AS "AUTOMOTIVE GRADE" MAY ONLY BE USED IN AUTOMOTIVE APPLICATIONS AT USER'S OWN RISK.**

Resale of ST products with provisions different from the statements and/or technical features set forth in this document shall immediately void any warranty granted by ST for the ST product or service described herein and shall not create or extend in any manner whatsoever, any liability of ST.

ST and the ST logo are trademarks or registered trademarks of ST in various countries.

Information in this document supersedes and replaces all information previously supplied.

The ST logo is a registered trademark of STMicroelectronics. All other names are the property of their respective owners

©2013 STMicroelectronics - All rights reserved.

STMicroelectronics group of companies

Australia - Belgium - Brazil - Canada - China - Czech Republic - Finland - France - Germany - Hong Kong - India - Israel - Italy - Japan - Malaysia - Malta - Morocco - Philippines - Singapore - Spain - Sweden - Switzerland - United Kingdom - United States of America

[www.st.com](http://www.st.com)