

Copy and face milling cutter heads

For milling cutter indexable inserts RD..1003., RD..12T3., RD..1604..

ATORN[®]

Application

For face milling and copy milling, light and medium chipping

Version

- Wear-resistant, nickel-plated version
- With internal cooling
- Clamping screw tightening torque (indexable insert) M3.5 = 3.5 Nm, M4.5 = 7.6 Nm

Art. No.	16035 425
Max. cutting edge diameter	125 mm
Length	55 mm
Bore diameter	40 mm
max. ap	4 mm
Number of cutting edges	8 PCS
Suitable indexable insert no.	34

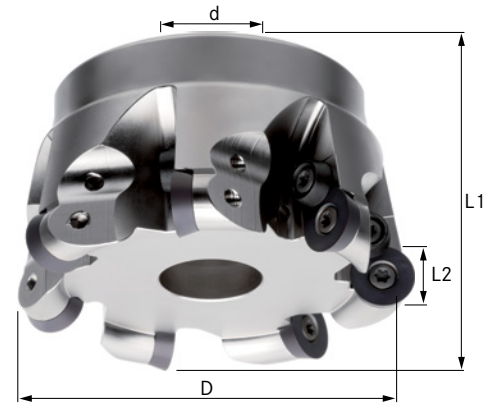

EAN-Code

4050293539356