

Revision Level		Revision Record	Changed	Date	Approval	Date
Part	Drawing					
	①	Remove bundle diameter.	Mandy Ong	09-Feb-09	Edward Tan	09-Feb-09
	②	Updated pictogramme and drawing template.	SIMON NG	10-Sep-19	Edward Tan	10-Sep-19
	③	Added HT Global project Number.	SIMON NG	10-Sep-19	Edward Tan	10-Sep-19
	④	Added cable tie dimensions chart.	SIMON NG	10-Sep-19	Edward Tan	10-Sep-19
	⑤	Remove tie head dimension.	SIMON NG	10-Sep-19	Edward Tan	10-Sep-19

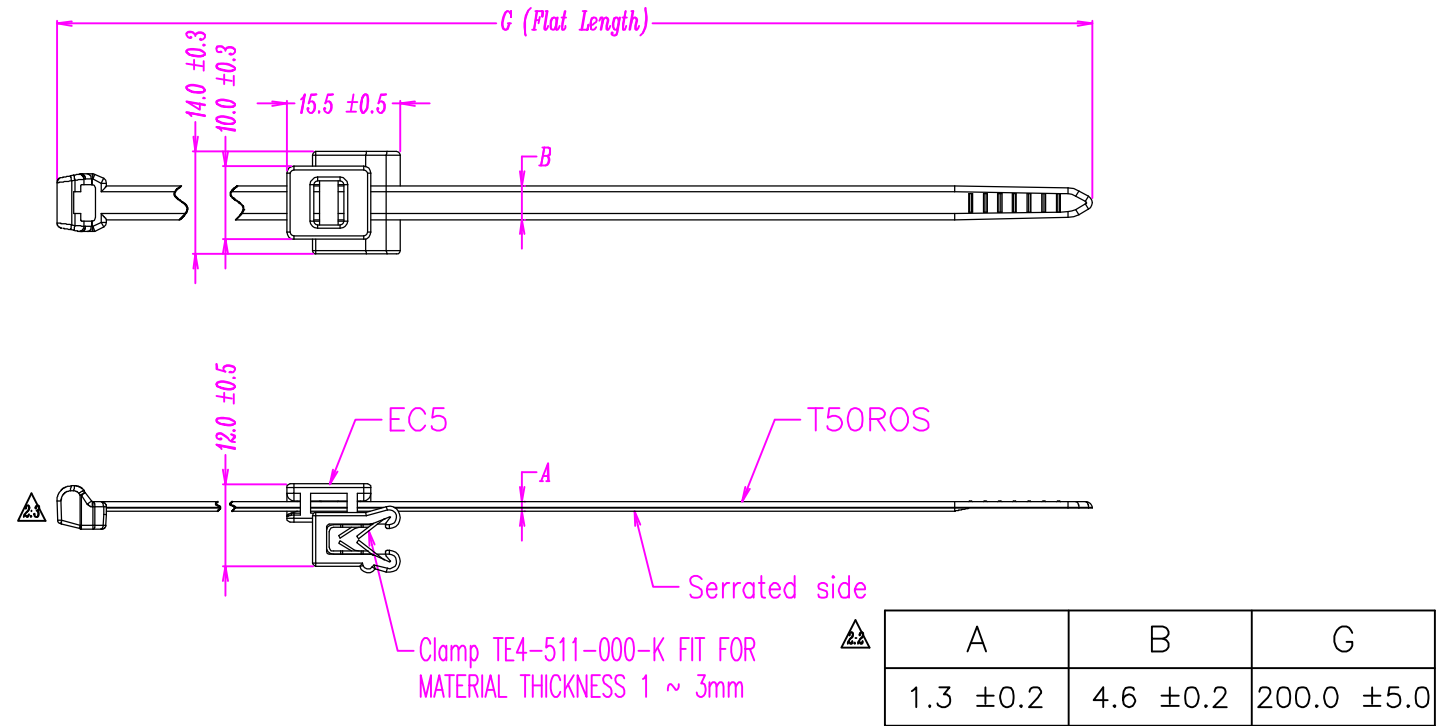

Material	P.A. 66
Tensile strength	225N (Minimum)
PERFORMANCE SPECIFICATION	

ACAD		Drawn	WENDY TAN	08 April 2008	Scale: 1 : 1	Reference: 14.1478	
The copyright of this drawing is reserved by HELLERMANN TYTON. It is issued on condition that it is not reproduced, copied or disclosed to a third party, either wholly or in part, without the consent of HELLERMANN TYTON.		Approved.	EDWARD TAN	08 April 2008	Title		
		<b>HellermannTyton</b>		T50ROSEC5A		Uncontrolled Document	
		545, Yishun Industrial Park A Yishun Avenue 7 Singapore 768741 Tel: (+65) 6852 8585 Fax: (+65) 6756 6798		Drawing-No [SG08010-02] 97-0405-014-CSH			
						Format	A4
						Sheet 1 of 1	