TECHNICAL REFERENCE

MODEL

Product name: AC Servo Amplifier
Product number: Minas-LIQI series

Issued on March 26, 2012
(REVISION . . .)

Received by

Date:

CHECKED	CHECKED	CHECKED	DESIGNED

Motor Business Unit, Appliances Company
Panasonic Corporation

7-1-1 Morofuku, Daito-City, Osaka 574-0044, Japan

Contents

1.	Specification Overview.....	1
2.	Specifications of Interface.....	2
2-1	Specifications of Input Signal of I/F Connector.....	2
2-2	Specifications of Output Signal of I/F Connector.....	4
2-3	Input/Output Signal Allocation.....	5
2-3-1	Allocation of Input Signal.....	5
2-3-2	Allocation of Output Signal.....	8
3.	Specifications of Front Panel.....	10
3-1	Rotary switch(RSW).....	10
3-2	7 segment LED.....	11
4.	Basic function.....	12
4-1	Setting Rotational Direction.....	12
4-2	Position control.....	13
4-2-1	Command Pulse Input.....	13
4-2-2	Command Scaling (Electronic Gear).....	15
4-2-3	Position Command Filter.....	16
4-2-4	Pulse Regeneration.....	18
4-2-5	Counter Clear (CL).....	21
4-2-6	In-position Output (INP).....	22
4-2-7	Command Pulse Inhibition (INH).....	23
4-3	Setting of Regenerative Resistor.....	24
5.	Gain Adjustment / Damping Control Functions.....	25
5-1	Automatic Adjusting Function.....	25
5-1-1	Real-time Auto Tuning.....	26
5-1-2	Adaptive Filter.....	31
5-2	Manual Adjustment.....	33
5-2-1	Block Diagram of Position Control Mode.....	34
5-2-2	Gain Switching Function.....	35
5-2-3	Notch Filter.....	39
5-2-4	Damping Control.....	41
5-2-5	Feed Forward Function.....	44
5-2-6	3rd Gain Switching.....	46
5-2-7	Friction Torque Compensation.....	47
6.	Applied Functions.....	49
6-1	Torque Limit Switching.....	49
6-2	Motor Movement Range Setting.....	50
6-3	Electronic Gear Switching.....	52
6-4	Setting of Sequence Movements.....	53
6-4-1	Drive prohibition input (POT , NOT) sequence.....	53
6-4-2	Sequence at Servo Off.....	54
6-4-3	Emergency Stop at Alarm.....	55
6-4-4	Emergency Stop at Alarm.....	56
7.	Protective/Warning Functions.....	57
7-1	List of Protective Functions.....	57
7-2	Details of Protective Functions.....	59
7-3	Warning Functions.....	64
7-4	Protection Function Setting before Gain Adjustment.....	65
8.	Others.....	67
8-1	List of parameters.....	67
8-2	Timing Chart.....	73
8-2-1	Timing Chart of Operations After Turning Power On.....	73

8-2-2 Timing Chart of Servo On/Off When Monitor is Turned Off.....	74
8-2-3 Timing Chart of Servo On/Off When Motor is Operating	74
8-2-4 Timing Chart of Operations When Alarm is Issued (Servo-On Command Status).....	75
8-2-5 Timing Chart of Operations When Alarm is Cleared (Servo-On Command Status)	76

1. Specification Overview

Basic Specification	Control method		IGBT PWM method sine wave drive		
	Control mode		Position Control		
	Encoder feedback		2500p/r(resolution: 10,000) 5-wire serial incremental encoder		
	Control signal	Input	6 multi-function inputs Functions of multi-function inputs: parameter-selectable		
		output	3 multi-function outputs Functions of multi-function outputs: parameter-selectable		
	Pulse signal	Input	1 inputs each Both line driver interface and open collector interface supported using optocoupler input		
		output	4 outputs each Encoder pulses (phase A, B and Z signals) or external scale pulses (phase EXA, EXB and EXZ signals) output by line driver. Open collector output is also available for phase Z and EXZ signals.		
	Communication function(USB)		Personal computer, etc. can be connected for parameter setting configuration and status monitoring.		
	Front panel		①7 seg LED 2pcs ②RSW 1pcs		
	Regeneration		External resistor		
Dynamic brake		Provided			
Function	Position control	Control input		Deviation counter clear, command pulse input inhibition, electronic gear switching, damping control switching, etc.	
		Control output		In-position, etc.	
		Input pulse	Maximum command pulse frequency	500 kpps	
			Input pulse train	Differential input; parameter-selectable (1) Positive/Negative 2) Phase A/Phase B 3) Command/Direction)	
			Command scaling (electric gear ratio setting)	1/1000 - thousandfold Encoder resolution (numerator) and command pulse count per motor revolution (denominator) can be arbitrarily specified between $1-2^{20}$ for numerator and $1-2^{20}$ for denominator but use within the range above.	
			Smoothing filter	Selectable between first order filter and FIR filter for command input.	
	Damping control		Available		
	Common	Auto tuning		Identifying load inertia real-time and automatically setting gain that meets set stiffness when the motor is driving by a operation command from the host or drive	
		Dividing encoder pulse		Pulse count can be arbitrarily specified (up to encoder pulse count).	
		Protective function		Overvoltage, undervoltage, overspeed, overload, overheat, overcurrent, encoder abnormalities Position deviation fault, Command pulse division, EEPROM error, etc.	
Alarm data trace back function		Alarm data history can be viewed.			

2. Specifications of Interface

2-1 Specifications of Input Signal of I/F Connector

Input signals and their functions

Category	Signal	Code	Connector pin No.	Item
Common	Power supply	COM+	1	· Plus terminal of an external 12 - 24 V DC power
		COM-	11	· Minus terminal of an external 12 - 24 V DC power
Input pulse	Command pulse input 1	PULS1	20	· Position command pulse input terminal dedicated for the line driver output. · This input is invalid with the default setting. · For details, see Section 4-2-1.
		PULS2	21	
	Command direction input 1	SIGN1	22	
		SIGN2	23	
Control input	Servo On	SRV-ON	2 (SI1) *	· Digital input to enable/disable the drive (with and without power to the motor).
	Positive overtravel limit	POT	7 (SI6) *	· This is an overtravel limit to the positive direction. · The operation when this input is turned on is set by Pr5.04 "Over-travel inhibit input setup". · Before use, set "Over-travel inhibit input setup" to any value other than 1, and connect pins so that the input is turned on when the signal input exceeds the moving range in the positive direction of the moving part of the machine.
	Negative overtravel limit	NOT	6 (SI5) *	· An overtravel limit to the negative direction. · The operation when this input is turned on is set by Pr5.04 "Over-travel inhibit input setup". · Before use, set "Over-travel inhibit input setup" to any value other than 1, and connect pins so that the input is turned on when the signal input exceeds the moving range in the negative direction of the moving part of the machine.
	Deviation counter clear	CL	4 (SI3) *	· Digital input to clear the deviation counter. · This input clears the counter at the edges with the default setting. To change the setting, use Pr5.17 "Counter clear input mode". · For details, see Section 4-2-5.
	Alarm clear	A-CLR	3 (SI2) *	· This input clears the alarm state. · Note some alarms cannot be cleared with this input.
	Command pulse inhibition input	INH	5 (SI4) *	· Digital input to inhibit the position command pulse input · Before use, set Pr5.18 "Invalidation of command pulse inhibit input" to 0. · For details, see Section 4-2-7.

*1 "-" in the table means that operations do not depend on "on/off" of the input signal.

Category	Signal	Code	Connector pin No.	Item
Control input	Command scaling switch 1	DIV1	–	· This input switches the command scaling numerator. · For details, see Section 6-4.
	Damping switch 1	VS-SEL1	–	· This input switches frequencies applied for the damping control. Together with the damping switch 2 (VS-SEL2), it is possible to switch between four frequencies at the maximum. · For details, see Section 5-2-4.
	Gain switch	GAIN	–	· Digital input to switch the gains between the 1st and 2nd in the servo loop. · For details, see Section 5-2-2.
	Torque limit switch	TL-SEL	–	· Digital input to switch between the 1st and 2nd torque limits. · For details, see Section 6-1.
	Damping switch 2	VS-SEL2	–	· This input switches frequencies applied for the damping control. Together with the damping switch 1 (VS-SEL1), it is possible to switch between four frequencies at the maximum. · For details, see Section 5-2-4.
	Command scaling switch 2	DIV2	–	· This input switches the command scaling. · For details, see Section 6-3.
	Forced Alarm Input	E-STOP	–	· Generates Err87.0 "Compulsory alarm input protection".

- The "*" mark attached to pin numbers displays that functions of signals and logics can be altered among pins with number Pr4.00 - Pr4.05 (SI* input selection). Note that pin numbers assignable to the following functions cannot be changed.
Deviation Counter Clear Input (CL): SI3; Command Pulse Inhibition Input (INH): SI4
- No function is allocated to the connector pins marked with "-" in the default setting.

2-2 Specifications of Output Signal of I/F Connector

Output signals and their functions

Category	Signal	Code	Connector pin No.	Item
Common	Frame ground	FG	Shell 26	· Internally connected with the earth terminal.
	Signal ground	GND	12	· Signal ground · The signal ground is internally isolated from the control signal power supply (COM-).
Pulse output	Phase A signal output	OA+	13	· Differential outputs after the parameterized scaling of either an encoder signal or an external scale signal (A, B, and Z phases) (RS422 equivalent). · The ground terminal of the line driver in the output circuit is connected to the signal ground (GND) and thus not isolated. · The maximum frequency of the pulse output is 4 Mpps after quadrature.
		OA-	14	
	Phase B signal output	OB+	15	
		OB-	16	
	Phase Z signal output	OZ+	17	
		OZ-	18	
Phase Z signal output	CZ	19	· Open collector output of phase Z signal · The emitter terminal of the transistor in the output circuit is connected to the signal ground (GND) and thus not isolated.	
Control output	Servo alarm output	ALM	8 (S01) *	· Digital output to display the alarm state. · Turns on the output transistor in a normal state, and turns off the output transistor when an alarm is issued.
	Servo ready output	S-RDY	10 (S03) *	· Digital output to display the driver is ready to be enabled. · The output transistor turns on when both the main and control power supplies are properly provided and no alarm is shown. · Turns on the output transistor after absolute data are transferred, when the absolute I/F function is valid in the absolute mode.
	Motor holding brake release	BRK-OFF	-	· Outputs a timing signal that activates the electromagnetic brake of the motor. · Turns on the output transistor at the time the electromagnetic brake is released.
	In-position	INP	9 (S02) *	· Digital output to give an in-position signal. · Turns on the output transistor in the in-position state. · For details, see Section 4-2-6.
	Torque limited	TLC	-	· Digital output to display the torque is limited. · Turns on the output transistor while torque is limited.
	Zero speed	ZSP	-	· Digital output to display the zero speed state. · Turns on the output transistor while zero-speed is detected.
Control output	In-position 2	INP2	-	· Outputs the in-position 2 signal. · Turns on the output transistor in the state of in-position. · For details, see Section 4-2-6.
	Warning 1	WARN1	-	· Outputs a warning output signal that has been set by Pr4.40 "Selection of alarm output 1". · Turns on the output transistor while a warning is issued.
	Warning 2	WARN2	-	· Outputs a warning output signal that has been set by Pr4.41 "Selection of alarm output 2". · Turns on the output transistor while a warning is issued.
	Output for presence/absence of position command	P-CMD	-	· Turns on the output transistor when a position command is present.
	Alarm clear attribute output	ALM-ATB	-	· Turns on the output transistor when an alarm that can be cleared is issued.
	Main Power output	P-ON	-	· Turns on the output transistor when the main DC power after commutating is in low level.

- The "*" mark attached to pin numbers displays that signal functions can be altered among pins with number Pr4.10 - Pr4.10 (which can be selected by SO* output).
- No function is allocated to the connector pins marked with "-" in the default setting.

2-3 Input/Output Signal Allocation

The assignment of the input/output signals can be changed from the default setting.

2-3-1 Allocation of Input Signal

An input signal that you wish can be assigned to an input pin of the I/F connectors. It is also possible to change the logic.

Note that for some signals, assignment is limited. For details, see (2) "Change the default assignment for input signals."

(1) Use the default signal assignment

The following table shows the default setting for the signal assignment.

Input signals*2	Corresponding parameter	Default value (): Decimal number	Default status	
			Signal	Logic *1
SI1 input	Pr4.00	00000003h (3)	SRV-ON	a connect
SI2 input	Pr4.01	00000004h (4)	A-CLR	a connect
SI3 input	Pr4.02	00000007h (7)	CL	a connect
SI4 input	Pr4.03	00000088h (136)	INH	b connect
SI5 input	Pr4.04	00000082h (130)	NOT	b connect
SI6 input	Pr4.05	00000081h (129)	POT	b connect

*1 "a connect" and "b connect" represent the following respectively:

a connect : A signal input is open with COM-, and thus the function is invalid (OFF state).

A signal input is connected with COM-, and thus the function is valid (ON state).

b connect : A signal input is open with COM-, and thus the function is valid (ON state).

A signal input is connected with COM-, and thus the function is invalid (OFF state).

In this specification, a signal input is defined ON when its function is valid; OFF when the function is invalid.

*2 For pin numbers assigned as input signals SI1 – SI10, see Specifications.

*3 The mark "-" displays that there is no function assigned.

(2) Change the default assignment for input signals
To reassign an input signal, change the following parameter.

Category	No.	Parameter	Setup range	Unit	Function
4	00	SI1 input selection	0~ 00FFFFFFh	-	To assign a function to the input SI1. Set this parameter with the hexadecimal system. *1 Following the hexadecimal form, set each control mode as follows: 0 0 0 0 0 0 * * h Enter a function number in the place marked with "**". Please refer to the function number table shown later in this section. The setting of logics is also included in the function numbers. If you wish to assign to a pin DIV1_a connect, the setting will be 0000000C h .
4	01	SI2 input selection	0~ 00FFFFFFh	-	To assign a function to the input SI2. Set this parameter with the hexadecimal system. Settings can be made in the same way for Pr4.00.
4	02	SI3 input selection	0~ 00FFFFFFh	-	To assign a function to the input SI3. Set this parameter with the hexadecimal system. Settings can be made in the same way for Pr4.00.
4	03	SI4 input selection	0~ 00FFFFFFh	-	To assign a function to the input SI4. Set this parameter with the hexadecimal system. Settings can be made in the same way for Pr4.00.
4	04	SI5 input selection	0~ 00FFFFFFh	-	To assign a function to the input SI5. Set this parameter with the hexadecimal system. Settings can be made in the same way for Pr4.00.
4	05	SI6 input selection	0~ 00FFFFFFh	-	To assign a function to the input SI6. Set this parameter with the hexadecimal system. Settings can be made in the same way for Pr4.00.

Function number table

Signal	Code	Setting	
		a connect	b connect
Invalid	-	00h	Not available
Positive overtravel limit	POT	01h	81h
Negative overtravel limit	NOT	02h	82h
Servo on	SRV-ON	03h	83h
Alarm clear	A-CLR	04h	Not available
(No setting)	-	05h	85h
Gain switch	GAIN	06h	86h
Deviation counter clear	CL	07h	Not available
Command pulse inhibition	INH	08h	88h
Torque limit switch	TL-SEL	09h	89h
Damping switch 1	VS-SEL1	0Ah	8Ah
Damping switch 2	VS-SEL2	0Bh	8Bh
Command scaling switch	DIV1	0Ch	8Ch
Command scaling switch 2	DIV2	0Dh	8Dh
(No setting)	-	0Eh~13h	8Eh~93h
Forced alarm input	E-STOP	14h	94h
(No setting)	-	15h	95h

Precautions:

- Do not set any value other than set values specified in the table. If it is set other than values specified in the table, Err33.2 "IF input function number error 1 protection" or Err33.3 "IF input function number error 2 protection" will occur. And the (No setting) in the table is set to protection function. Because input do not operate, please set it to invalid(00h).
- A function can not be assigned to more than one signal. If any function is assigned to more than one signal, Err33.0 "IF overlaps allocation error 1 protection" and Err33.1 "IF overlaps allocation error 2 protection" will occur.
- Deviation Counter Clear (CL) can be assigned only to SI7 Input. If it is assigned to the other signals, Err33.6 "CL fitting error protection" will occur.
- Command Pulse Inhibition (INH) can be assigned only to SI10 Input. If it is assigned to the others, Err33.7 "INH fitting error protection" will occur.
- Control input pins set as invalid do not affect operations.
- Servo-on Input Signal (SRV-ON) must always be assigned. When it is not assigned, Servo-on cannot be activated

2-3-2 Allocation of Output Signal

Output signals can assign any function except Servo Alarm Output (ALM) to output pins of the I/F connector. The logic cannot be changed for the output pins.

(1) Use the default signal assignment

The following table shows the default setting for the signal assignment.

Output signals *1	Corresponding parameter	Default value (): Decimal number	Default status
			Signal
SO1 output	Pr4. 10	00000001h (1)	ALM
SO2 output	Pr4. 11	00000004h (4)	INP
SO3 output	Pr4. 12	00000002h (2)	S-RDY

*1 For pin numbers assigned as output signals SO1 – SO3, see Specifications.

(2) Change the default assignment for output signals

To reassign an output signal, change the following parameter.

Category	No.	Parameter	Setup range	Unit	Function
4	10	SO1 output selection	0~ 00FFFFFFh	-	To assign a function to the output SO1. Set this parameter with the hexadecimal system.*1 Following the hexadecimal form, set each control mode as follows: 0 0 0 0 0 0 * * h Enter a function number in the place marked with "**". Please refer to the function number table shown later in this section.
4	11	SO2 output selection	0~ 00FFFFFFh	-	To assign a function to the output SO2. Set this parameter with the hexadecimal system. Settings can be made in the same way for Pr4.10.
4	12	SO3 output selection	0~ 00FFFFFFh	-	To assign a function to the output SO3. Set this parameter with the hexadecimal system. Settings can be made in the same way for Pr4.10.

Function number table

Signal	Code	Setting
Invalid	-	00h
Servo alarm output	ALM	01h
Servo ready output	S-RDY	02h
Motor holding brake release	BRK-OFF	03h
In-position	INP	04h
(No setting)	-	05h
Torque limited	TLC	06h
Zero speed	ZSP	07h
(No setting)	-	08h
Warning 1	WARN1	09h
Warning 2	WARN2	0Ah
Output for presence/absence of position command	P-CMD	0Bh
In-position 2	INP2	0Ch
(No setting)	-	0Dh
Alarm attribute output	ALM-ATB	0Eh
(No setting)	-	0Fh
Main power on output	P-ON	10h

Precautions:

- The same function can be assigned to multiple output signals.
- A control output pin set as invalid normally keeps the output transistor turned off.
- Do not set any value other than set values specified in the table.
If it is set to other than set values specified in the table, Err33.4 「I/F output function code error will occur. And the (No setting) in the table is set to protection function..If it is set to any values ,output will get unstable.

3. Specifications of Front Panel

3-1 Rotary switch(RSW)

By manipulating the RSW, Pr.0.03(selection of stiffness at real-time auto-gain tuning) was corrected by setting the RSW, and can be changed from the front panel gain control.

RSW setting	The stiffness correction	Example) Pr0. 03=8		Parameter Pr0.03 is changed
		Stiffness after correction	LED Display	
PC	± 0	8	Pc	Possible
+1	+1	9	9	Impossible
+2	+2	10	10	
+3	+3	11	11	
+4	+4	12	12	
+5	+5	13	13	
+6	+6	14	14	
+7	+7	15	15	
-	± 0	8	8	
-7	-7	1	1	
-6	-6	2	2	
-5	-5	3	3	
-4	-4	4	4	
-3	-3	5	5	
-2	-2	6	6	
-1	-1	7	7	

*1 The setting value is 0 that the **arrow of** rotary switch  upward direction. The value is increased while the arrow is turned by clockwise direction.

3-2 7 segment LED

At power-up after displaying the check pattern, perform the following normal display.
 If you operate the front RSW will show the real-time stiffness value of RSW after adjustment for the front.
 However, when an alarm occurs when an alert will display a warning code, the alarm code (main + sub).

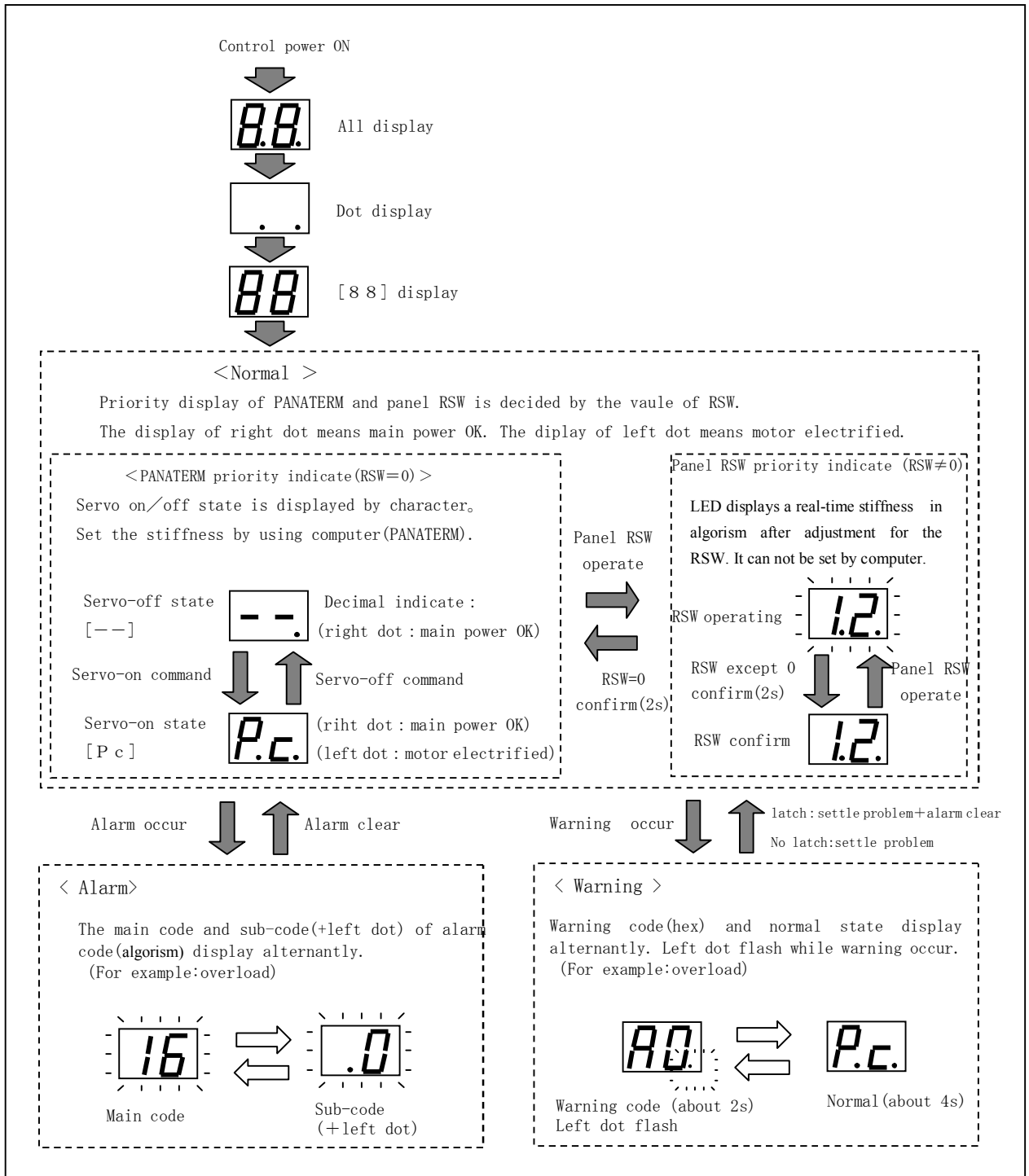

4. Basic function

4-1 Setting Rotational Direction

The rotation direction of the motor to the directions of position command can be switched.

■ Related parameters

Category	No.	Parameter	Setup range	Unit	Function
0	0	Rotational direction setup	0~1	-	Specifies the relationship between the commanded direction and the direction of rotation of the motor. 0 : CW motor rotation for positive direction command 1 : CCW motor rotation for positive direction command

As the direction of motor rotation, clockwise as seen from the shaft end to the load is defined as CW and counterclockwise as CCW

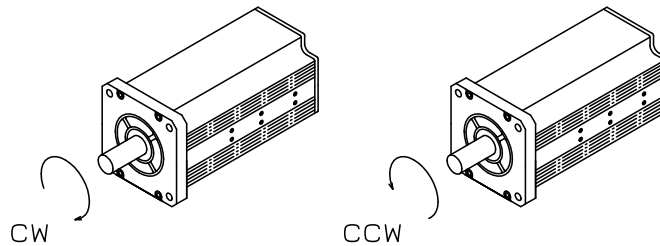

The positive or negative direction referred to in this document displays the direction as specified with this parameter. The table below shows the relationships with positive overtravel limit and negative overtravel limit as examples.

Pr0.00	Command direction	Direction of motor rotation	Positive overtravel limit	Negative overtravel limit
0	Positive	CW	Enabled	-
0	Negative	CCW	-	Enabled
1	Positive	CCW	Enabled	-
1	Negative	CW	-	Enabled

4-2 Position control

Position control is performed based on a position command (pulse train) input from the controller. This section describes basic settings for position control.

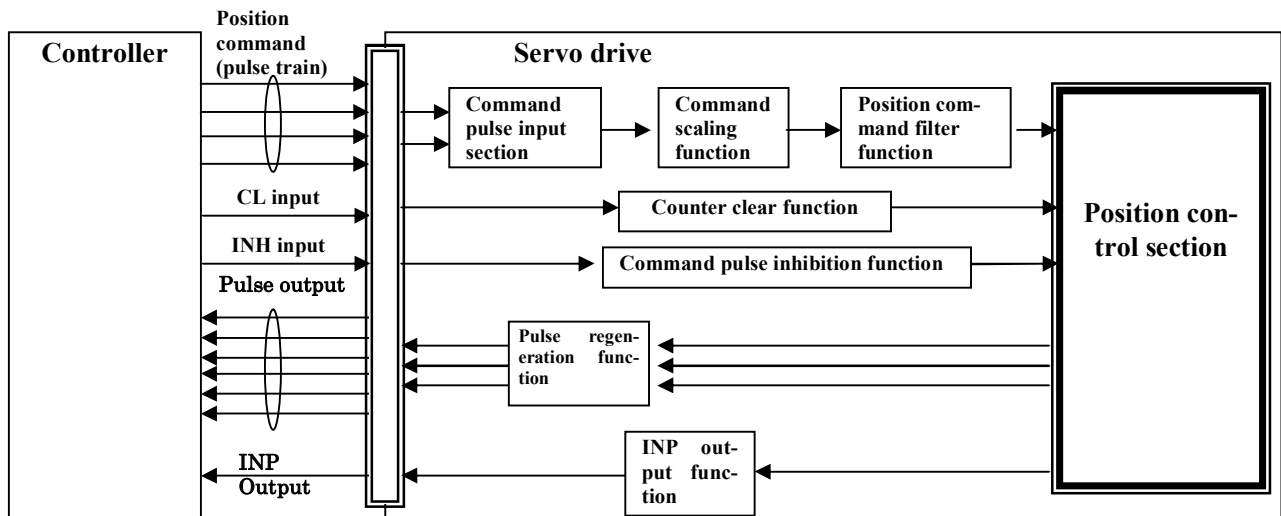

4-2-1 Command Pulse Input

The input of position command (pulse train) use PULS1, PULS2, SIGN1, SIGN2.

Three command pulse formats are supported: 2-phase pulse, positive pulse train/negative pulse train and pulse train + sign. The pulse format must be selected out of the three and the pulse counting direction must be specified according to the specifications of the controller and equipment installation condition.

■ Related parameters

Category	No.	Parameter	Setup range	Unit	Function
0	6 *	Command pulse rotational direction setup	0~1	—	Specifies the counting direction for command pulse input. See the table on the following page for the details.
0	7 *	Command pulse input mode setup	0~3	—	Specifies the counting mode for command pulse input. See the table on the following page for the details.

The following table shows the combinations of Pr0.06 "Command pulse rotational direction setup" and Pr0.07 "Command pulse input mode setup"

Pulses are counted at the edges with arrows in the table.

Pr0.06	Pr0.07	Command pulse	Signal	Positive command	Negative command
0	0 or 2	2-phase pulse with 90° difference (Phase A + Phase B)	PULS		
			SIGN		
	1	Positive pulse train + Negative pulse train	PULS		
			SIGN		
	3	Pulse train + Sign	PULS		
			SIGN		
1	0 or 2	2-phase pulse with 90° difference (Phase A + Phase B)	PULS		
			SIGN		
	1	Positive pulse train + Negative pulse train	PULS		
			SIGN		
	3	Pulse train + Sign	PULS		
			SIGN		

PULS/SIGN signal		Max. allowable input frequency	Minimum required time width [μs]					
			t1	t2	t3	t4	t5	t6
PULS1, 2, SIGN1, 2	Line driver	500 kpps	2	1	1	1	1	1
	Open collector	200 kpps	5	2.5	2.5	2.5	2.5	2.5

4-2-2 Command Scaling (Electronic Gear)

This function multiplies a pulse command value input from the controller by the specified scaling factor to use as a position command to the position control section. Using this function allows arbitrary setting of the motor revolution and distance per unit input command pulse and increase of a command pulse frequency when the required motor speed cannot be obtained due to the limit to the controller pulse output capability.

■ Related parameters

Category	No.	Parameter	Setup range	Unit	Function
0	08	Command pulse counts per one motor revolution	0~1048576	pulse	Specifies the command pulse count corresponding to one revolution of the motor. When this setting is 0, Pr0.09 "1st numerator of electronic gear" and Pr0.10 "Denominator of electronic gear" are valid. This setting is invalid in full-closed control.
0	09	1st numerator of electronic gear	0~1073741824	—	Specifies the numerator for scaling for a command pulse input. Valid when Pr0.08 "Command pulse counts per one motor revolution" is 0 or in full-closed control. When this parameter is set to 0, the encoder resolution is set to the numerator for position control, and for full-closed control, the command scaling ratio becomes 1:1.
0	10	Denominator of electronic gear	1~1073741824	—	Specifies the denominator for scaling for a command pulse input. Valid when Pr0.08 "Command pulse counts per one motor revolution" is 0 or in full-closed control.

The relationships between Pr0.08, 0.09, and 0.10 in position control

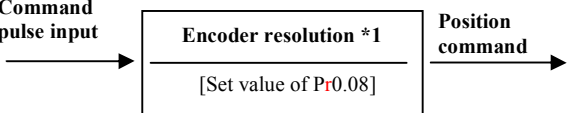
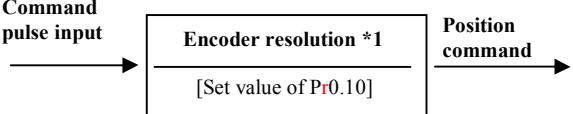
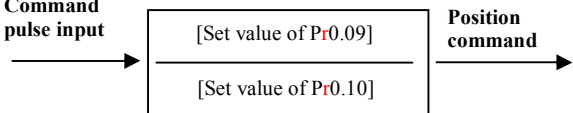
Pr0.08	Pr0.09	Pr0.10	Command scaling
1~1048576	— (No effect)	— (No effect)	 <p>* The process shown in the above diagram is executed in accordance with the set value of Pr0.08, regardless of settings of Pr0.09 and Pr0.10.</p>
0	0	1~1073741824	 <p>* When the set value of both Pr0.08 and Pr0.09 is 0, the process shown in the above diagram is executed in accordance with the set value of Pr0.10.</p>
	1~1073741824	1~1073741824	 <p>* When the set value of Pr0.08 is 0 and that of Pr0.09 is not 0, the process shown in the above diagram is executed in accordance with the set values of Pr0.09 and Pr0.10.</p>

4-2-3 Position Command Filter

A command filter can be specified to smooth a position command after scaling (electric gear).

■ Related parameters

Category	No.	Parameter	Setup range	Unit	Function
2	22	Position command smoothing filter	0~10000	0.1 ms	Specifies the first order filter time constant for a position command.
2	23	Position command FIR filter	0~10000	0.1 ms	Specifies the FIR filter time constant for a position command.

· Pr2.22 "Position command smoothing filter"

Specifies the first order filter time constant for a square wave command with a target velocity of V_c as shown in the figure below.

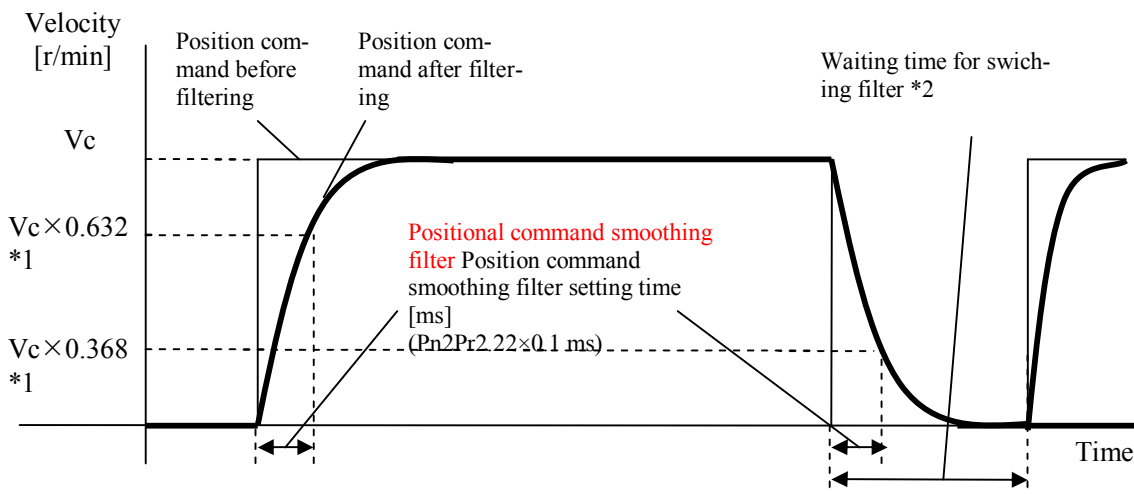

*1 Actual filter time constant contains absolute error of 0.4 ms maximum when the set value multiplied by 0.1 ms is less than 100 ms and relative error of 0.2% maximum when the set value multiplied by 0.1 ms is 20 ms or greater.

*2 Pr2.22 " Positional command smoothing filter " is switched when "in-position" is being output and when a command whose command pulse per time (0.166 ms) changes from 0 to any state except 0 is rising. Specifically when filter time constant is decreased and the in-position range is increased, the motor may temporarily rotates at a faster speed than the command speed if accumulated pulses—an area acquired by integrating the difference between the position command before filtering and the position command after filtering by time—are left in the filter at the point above. This is because accumulated pulses are rapidly cleared immediately after the switching and the motor goes back to the initial position. Use caution.

*3 There is a delay until the change in Pr2.22 " Positional command smoothing filter " is applied to internal calculation. If the switching timing described in *2 comes during the delay, the change may be suspen

· Pr2.23 "Position command FIR filter"

Specifies the time required to reach V_c for a square wave command with a target velocity of V_c as shown in the figure below.

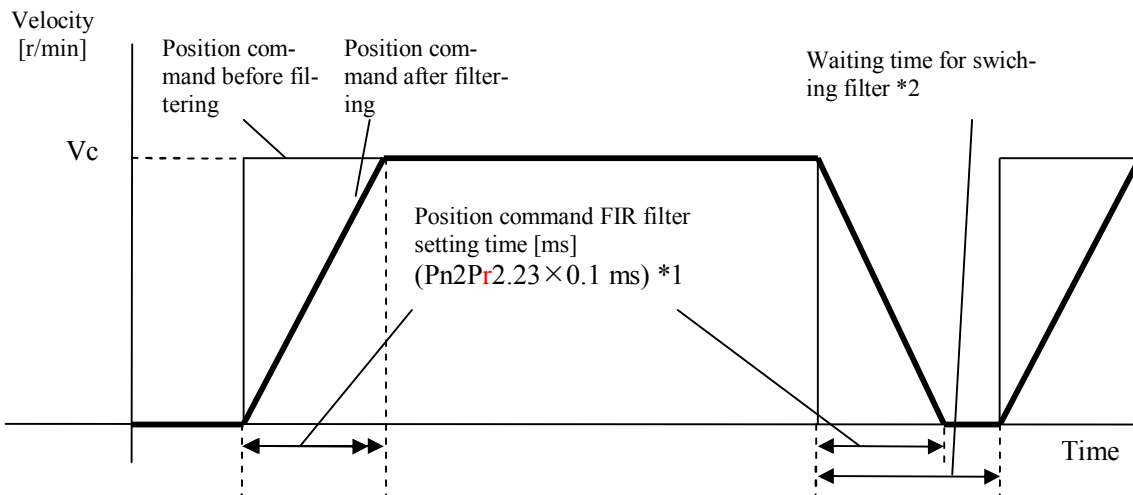

- *1 Actual average travel times contains absolute error of 0.2 ms maximum when the set value multiplied by 0.1 ms is less than 10 ms and relative error of 1.6% maximum when the set value multiplied by 0.1 ms is 10 ms or greater.
- *2 Before changing Pr2.23 "Position command FIR filter," stop the command pulse, and wait until the time for filter switching passes. The time for filter switching is as follows: the set value × 0.1 ms + 0.25 ms in the range of 10 ms or smaller, and the set value × 0.1 ms × 1.05 ms in the range of 10 ms or greater. When changing Pr2.23 "Position command FIR filter" during inputting a command pulse, the change is not updated immediately. It is updated when no command pulse is present during the time for filter switching.
- *3 There is a delay until the change in Pr2.23 "Position command FIR filter" is applied to internal calculation. If the switching timing described in *2 comes during the delay, the change may be suspended.

4-2-4 Pulse Regeneration

A distance can be transmitted from the servo drive as phase A and phase B pulses signal to the controller. If the output source is an encoder, the phase Z signal is output one time per rotation of the motor.

■ Related parameters

Category	No.	Parameter	Setup range	Unit	Function
0	11	Output pulse counts per one motor revolution	1~262144	P/r	Specifies the output pulse resolution as the output pulse count per rotation for OA and OB. Accordingly, if the pulse count has been multiplied by 4, the equation below applies. Output pulse resolution per rotation = Set value of Pr0.11 × 4
0	12	Reversal of pulse output logic	0~3	—	Specifies the logic of the pulse output phase B signal and the output source. Reversing the phase B pulse logic allows the phase relation of phase B pulse with reference to phase A pulse. In the full-closed control mode, an encoder or external scale can be chosen as the output source. The output source must be an encoder in other than full-closed control modes.
5	03	Denominator of pulse output division	0~262144	—	If the output pulse counts per one motor revolution is not an integer, set "Denominator of pulse output division" to any value except 0. It is also set using a divider ratio with Pr0.11 as the numerator and Pr5.03 as the denominator. Accordingly, if the pulse count has been multiplied by 4, the equation below applies. Output pulse resolution per rotation = (Set value of Pr0.11 / Set value of Pr5.03) × Encoder resolution
5	33	Pulse regenerative output limit setup	0~1	—	Set the error detection function (Err28.0 "Limit of pulse replay error protection") as valid or invalid. 0: Invalid 1: Valid

The following table shows combinations of Pr0.11 "Output pulse counts per one motor revolution" and Pr5.03 "Denominator of pulse output division".

Pr0.11	Pr5.03	Pulse regeneration output processing
1~262144	0	<p style="text-align: center;">[When the output source is the encoder]</p> <div style="display: flex; align-items: center; justify-content: center;"> <div style="text-align: right; margin-right: 10px;">Encoder pulse [pulse]</div> <div style="border: 1px solid black; padding: 5px; margin: 0 10px;"> $\frac{[\text{Set value of Pr0.11}] \times 4}{\text{Encoder resolution}}$ </div> <div style="text-align: left; margin-left: 10px;">Output pulse [pulse]</div> </div> <p>* When Pr5.03 is set as 0, the process shown above is executed in accordance with the set value of Pr0.11. Accordingly, each of OA and OB of pulse regeneration output will be identical to the number of pulses set in Pr0.11. The output pulse resolution will not be identical to the encoder pulse resolution or greater.</p>
1~262144	1~262144	<div style="display: flex; align-items: center; justify-content: center;"> <div style="text-align: right; margin-right: 10px;">Encoder FB pulse [pulse]</div> <div style="border: 1px solid black; padding: 5px; margin: 0 10px;"> $\frac{[\text{Set value of Pr0.11}]}{[\text{Set value of Pr5.03}]}$ </div> <div style="text-align: left; margin-left: 10px;">Output pulse [pulse]</div> </div> <p>* When Pr5.03 ≠ 0, the process above takes place based on the Pr0.11 and Pr5.03 settings, which allows applications where the pulse count per rotation of the pulse regeneration output OA and OB is not an integer. Note that when the pulse output resolution per rotation is not a multiple of 4, output of phase Z may not be synchronous with phase A, resulting in a smaller pulse width. The output pulse resolution will not be identical to the encoder pulse resolution or greater.</p>

Details of Pr0.12 "Reversal of pulse output logic" are shown below.

Pr0.12	Ph B logic	Output source	For positive direction	For negative direction
0	Non-reversed	Encoder	<p>PH A </p> <p>PH B </p>	<p>PH A </p> <p>PH B </p>
1	Reverse	Encoder	<p>PH A </p> <p>PH B </p>	<p>PH A </p> <p>PH B </p>

*Please do not set setting 2 and 3.

■ Notes on pulse regeneration function

- The maximum output frequency of pulse regeneration output is 4 Mpps (after multiplying by 4). Operation at a speed exceeding this may cause faulty functioning of regeneration leading to displacement.

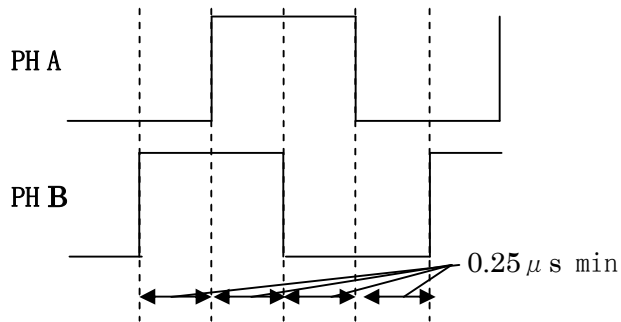

By Pr5.33 "Pulse regenerative output limit setup", Err28.0 "Limit of pulse replay error protection" can be issued when reaching the limit of pulse regeneration. Note that this error message is issued by detecting the output limit of pulse regeneration, not using the maximum output frequency. The error message may be issued when frequency jumps instantaneously, depending on the rotational state of the motor such as rotational fluctuation.

- When the output source is an encoder and the pulse output resolution per rotation is not a multiple of 4, phase Z may not be synchronous with phase A, leading to a smaller pulse width.

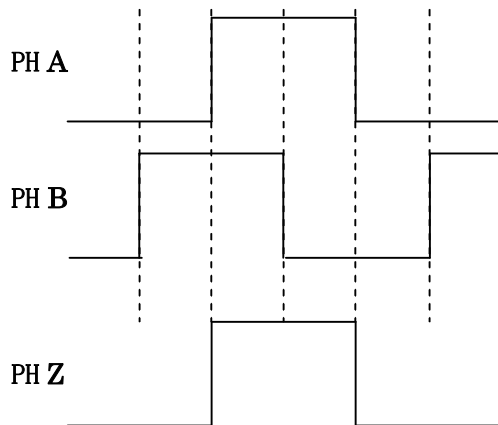

Scaling factor: multiple of 4

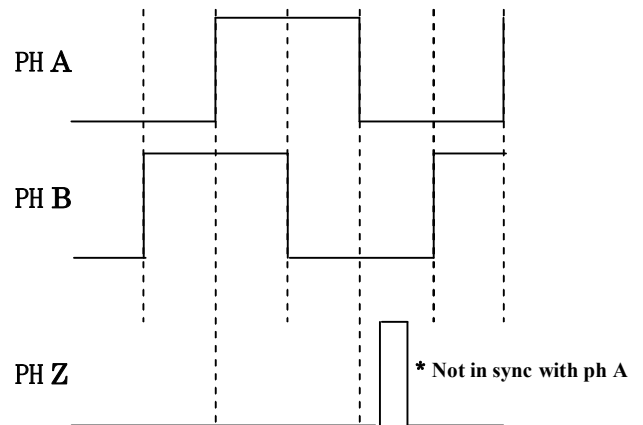

Scaling factor: not multiple of 4

* If Pr5.03 = 0 and output resolution is specified with Pr0.11, factor is always a multiple of 4.

- When an incremental encoder is used, the first phase Z signal after power-up may not agree with the pulse width as shown above. When using a phase Z signal, operate the motor by at least one rotation after power-up, make sure that the phase Z signal has been regenerated once and use the second or later phase Z signal.

4-2-5 Counter Clear (CL)

This function allows the position deviation counter value in position control to be cleared to 0 by using a deviation counter clear input (CL).

■ Related parameters

Category	No.	Parameter	Setup range	Unit	Function
5	17	Counter clear input mode	0~4	—	Selects the input mode of deviation counter clear input. 0: Invalid 1: Clear by level (without reading filter) 2: Clear by level (with reading filter) 3: Clear by edge (without reading filter) 4: Clear by edge (with reading filter)

For signal width and timing of deviation clear that need deviation counter clear input (CL), see the table below.

Pr5.17	CL signal width	Timing of clearing deviation
1	500 μ s or longer	Continue to clear when the deviation counter clear input is ON*1.
2	1 ms min.	
3	100 μ s or longer	Clear once at the edge*1 where the deviation counter clear input turns ON.
4	1 ms min.	

*1 The deviation counter clear input being OFF represents the input photocoupler being OFF, and the deviation counter clear input being ON represents the input photocoupler being ON.

4-2-6 In-position Output (INP)

Whether or not positioning has been completed can be checked with the In-position output (INP). This signal is turned on when the absolute value of the deviation counter value in position control is in the in-position range specified with the parameter. Settings such as including in the criteria whether or not a position command has been given are also available.

■ Related parameters

Category	No.	Parameter	Setup range	Unit	Function
4	31	Positioning complete (In-position) range	0~262144	Command unit	Set the threshold of position deviation that outputs the in-position signal (INP1). The unit is command by default, but it can be changed to encoder in Pr5.20 "Position setup unit select". Note that in that case, the unit of Pr0.14 "Position deviation excess setup" is also changed.
4	32	Positioning complete (In-position) output setup	0~3	-	Selects a condition to output the in-position signal (INP1). 0: The signal turns ON when the position deviation does not exceed Pr4.31 "Positioning complete (In-position) range". 1: The signal turns ON when there is no position command and the position deviation does not exceed Pr4.31 "Positioning complete (In-position) range". 2: The signal turns ON when there is no position command, the zero-speed detection signal is ON, and the position deviation does not exceed Pr4.31 "Positioning complete (In-position) range". 3: The signal turns ON when there is no position command and the position deviation does not exceed Pr4.31 "Positioning complete (In-position) range". Then, the signal remains turned ON until Pr4.33 "INP hold time" is over. After "INP hold time" is over, the INP output turns ON/OFF depending on the status of position command or position deviation.
4	33	INP hold time	0~30000	1 ms	Set the hold time for Pr4.32 "Positioning complete (In-position) output setup" being set as 3. 0: The hold time is infinite and the ON status is maintained until the next position command is given. 1 - 30000: The motor remains turned ON for the period set [ms]. Note that the motor is turned OFF when a position command is issued during the hold time.
4	42	2nd Positioning complete (In-position) range	0~262144	Command unit	Set the threshold of position deviation that outputs the in-position signal 2 (INP2). INP2 turns ON whenever the position deviation does not exceed the value set in this setting, regardless of Pr4.32 "Positioning complete (In-position) output setup". (The presence/absence of a position command is irrelevant.) The unit is command by default, but it can be changed to encoder in Pr5.20 "Position setup unit select". Note that in that case, the unit of Pr0.14 "Position deviation excess setup" is also changed.

- The presence/absence of a position command is judged by a command issued after the position command filter.
For the position command filter, see Section 4-2-3 "Position Command Filter."

4-2-7 Command Pulse Inhibition (INH)

The command pulse inhibition input signal (INH) can be used to force the command pulse input processing to stop.

Turning the INH input on forces the servo drive to ignore the command pulse input and the pulse counting does not take place.

This function is disabled by the factory setting. Before use, change the setting of Pr5.18 "Invalidation of command pulse inhibit input".

■ Related parameters

Category	No.	Parameter	Setup range	Unit	Function
5	18	Invalidation of command pulse inhibit input	0~1	—	Enables/disables the command pulse inhibition input. 0: Enable 1: Disable
5	19	Command pulse inhibit input reading setup	0~4	—	Selects the cycle of reading the signal of command pulse inhibition input. Updates the status of signal when it is periodically read and found the same twice or more. 0: 0.166 ms 1: 0.333 ms 2: 1 ms 3: 1.666 ms 4: 0.166 ms (when the signal is found the same twice or more) A prolonged cycle of reading decreases the likelihood of misoperation caused by noise, but it also reduces responsiveness to signal input.

4—3 Setting of Regenerative Resistor

This section describes the settings concerning the regenerative resistor.

For detailed specifications of the regenerative resistor.

■ Related parameters

Category	No.	Parameter	Setup range	Unit	Function
0	16	External regenerative resistor setup	0~3	—	Set this parameter according to whether the built-in regenerative resistor is used as it is or the built-in resistor is isolated and an external regenerative resistor is provided. 0: Use the built-in resistor and provide regeneration over. 1: Use an external resistor and provide regeneration over. 2: Use an external resistor but not provide regeneration over. 3: Use with no regenerative resistor (no regeneration over).

5. Gain Adjustment / Damping Control Functions

5-1 Automatic Adjusting Function

The following figure shows an overview of automatic adjustment function.

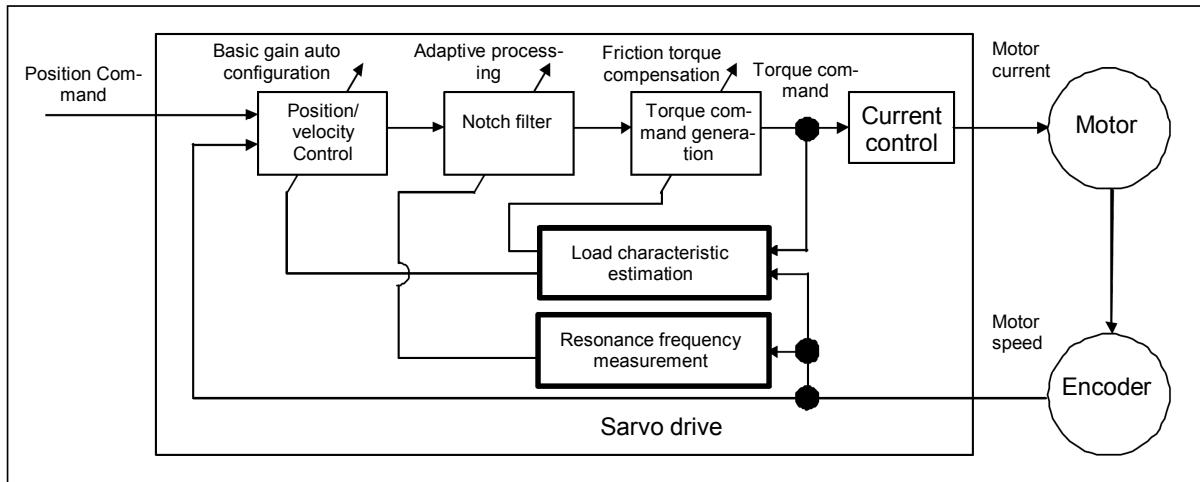

1) Real-time auto tuning

This function estimates load characteristic using motor speed and torque command, and automatically specifies basic gain with regard to position control and speed control on the basis of inertia estimation value. At the same time, setting time for positioning is reduced by adding an estimated friction torque to a torque command in advance.

2) Adaptive filter

Estimating a resonance frequency using a motor speed and removing the frequency components from a torque command suppresses vibrations caused by resonance.

5-1-1 Real-time Auto Tuning

Load characteristic of a machine is estimated on a real-time basis, and using the results, basic gain settings and friction compensation are automatically specified in accordance of hardness parameters.

1) Scope of application

This function is enabled under the following conditions:

	Conditions for real-time auto tuning
Operation status	<ul style="list-style-type: none"> · In Servo On status. · Parameters for other functions than control, such as deviation counter clearing, input signals such as command input prohibition, and torque limit settings, must be specified appropriately and normal rotation of motor must have no problems.

2) Cautions

Real-time auto tuning may not normally function in the following conditions. If that happens, change the load conditions/operation pattern or see the descriptions about manual tuning to manually configure relevant parameters.

	Conditions hindering real-time auto tuning
Load condition	<ul style="list-style-type: none"> · The load inertia is too small or large with reference to the rotor inertia (smaller than three times or 20 times or larger). · The load inertia varies. · The mechanical stiffness is extremely low. · Any non-linear characteristic exists such as backlash.
Operation pattern	<ul style="list-style-type: none"> · Continuous use at a low speed of less than 100 [r/min] · The acceleration is low at 2000 [r/min] per 1 [s]. · A speed at 100 [r/min] or higher or a acceleration/deceleration of 2000 [r/min] per 1 [s] does not continue for 50 [ms] or longer. · The acceleration/deceleration torque is small with reference to the uneven load/viscous friction torque.

3) Parameters controlling operation of real-time auto tuning

Configure the real-time auto tuning operation by setting the following parameters.

Category	No.	Parameter	Setup range	Unit	Function																								
0	02	Real-time auto-gain tuning setup	0~6	-	<p>Specifies the operation mode of real-time auto tuning.</p> <table border="1"> <thead> <tr> <th>Setting</th> <th>Mode</th> <th>Description</th> </tr> </thead> <tbody> <tr> <td>0</td> <td>Invalid</td> <td>The real-time auto tuning function is disabled.</td> </tr> <tr> <td>1</td> <td>Standard</td> <td>The mode for the optimum stability. No uneven load or friction compensation takes place and no gain switching is used.</td> </tr> <tr> <td>2</td> <td>Positioning</td> <td>The mode for the optimum positioning. Used for a ball screw-driven device, etc. with no uneven load and little friction, as in a horizontal axis.</td> </tr> <tr> <td>3</td> <td>Vertical axis</td> <td>In addition positioning mode, compensation against biased load on vertical axis is made to reduce variations in settling time of positioning.</td> </tr> <tr> <td>4</td> <td>Friction compensation</td> <td>In addition to the vertical axis mode, settling time of positioning is reduced for belt-drive axis where frictions are high.</td> </tr> <tr> <td>5</td> <td>Load characteristic measurement</td> <td>Basic gain settings and friction compensation settings are not changed and load characteristic estimation only is made. This is used in combination with setup support software.</td> </tr> <tr> <td>6</td> <td>(No setting)</td> <td>It can not be used.</td> </tr> </tbody> </table>	Setting	Mode	Description	0	Invalid	The real-time auto tuning function is disabled.	1	Standard	The mode for the optimum stability. No uneven load or friction compensation takes place and no gain switching is used.	2	Positioning	The mode for the optimum positioning. Used for a ball screw-driven device, etc. with no uneven load and little friction, as in a horizontal axis.	3	Vertical axis	In addition positioning mode, compensation against biased load on vertical axis is made to reduce variations in settling time of positioning.	4	Friction compensation	In addition to the vertical axis mode, settling time of positioning is reduced for belt-drive axis where frictions are high.	5	Load characteristic measurement	Basic gain settings and friction compensation settings are not changed and load characteristic estimation only is made. This is used in combination with setup support software.	6	(No setting)	It can not be used.
Setting	Mode	Description																											
0	Invalid	The real-time auto tuning function is disabled.																											
1	Standard	The mode for the optimum stability. No uneven load or friction compensation takes place and no gain switching is used.																											
2	Positioning	The mode for the optimum positioning. Used for a ball screw-driven device, etc. with no uneven load and little friction, as in a horizontal axis.																											
3	Vertical axis	In addition positioning mode, compensation against biased load on vertical axis is made to reduce variations in settling time of positioning.																											
4	Friction compensation	In addition to the vertical axis mode, settling time of positioning is reduced for belt-drive axis where frictions are high.																											
5	Load characteristic measurement	Basic gain settings and friction compensation settings are not changed and load characteristic estimation only is made. This is used in combination with setup support software.																											
6	(No setting)	It can not be used.																											
0	03	Selection of machine stiffness at realtime auto-gain tuning	0~31	-	<p>Specifies the response for enabled real-time auto tuning. A larger setting increases the speed response and servo stiffness but invites more vibration. Gradually increase the setting while monitoring the operation.</p> <p>While the RSW is not 0, the value of parameter can be corrected by actual setting of RSW. Please refer to 3. the front panel specification.</p>																								
6	31	Real time auto tuning estimation speed	0~3	-	<p>Specifies the load characteristics estimation speed for enabled real-time auto tuning. A larger setting allows faster follow-up to the variation in the load characteristics but also increases estimation fluctuation due to disturbance. The result of estimation is stored in the EEPROM every 30 minutes.</p> <table border="1"> <thead> <tr> <th>Setting</th> <th>Mode</th> <th>Description</th> </tr> </thead> <tbody> <tr> <td>0</td> <td>No change</td> <td>Terminates estimation of load characteristic.</td> </tr> <tr> <td>1</td> <td>Little change</td> <td>Responded against change of load characteristic on the order of minutes.</td> </tr> <tr> <td>2</td> <td>Gradual change</td> <td>Responded against change of load characteristic on the order of seconds.</td> </tr> <tr> <td>3 *</td> <td>Steep change</td> <td>Appropriate estimation is made against change of load characteristic.</td> </tr> </tbody> </table> <p>* If oscillation automatic detection is made valid from setup support software, this setting is ignored and operation is based on settings of setting value 3.</p>	Setting	Mode	Description	0	No change	Terminates estimation of load characteristic.	1	Little change	Responded against change of load characteristic on the order of minutes.	2	Gradual change	Responded against change of load characteristic on the order of seconds.	3 *	Steep change	Appropriate estimation is made against change of load characteristic.									
Setting	Mode	Description																											
0	No change	Terminates estimation of load characteristic.																											
1	Little change	Responded against change of load characteristic on the order of minutes.																											
2	Gradual change	Responded against change of load characteristic on the order of seconds.																											
3 *	Steep change	Appropriate estimation is made against change of load characteristic.																											

4) Parameter changed by real-time auto tuning

The real-time auto tuning function updates the following parameters using load characteristic values, in accordance with Pr0.02 "Real-time auto-gain tuning setup".

Category	No.	Parameter	Setup range	Unit	Function
0	04	Inertia ratio	0~10000	%	This parameter is updated if updating inertia ratio of real-time auto tuning is valid.
6	07	Torque command additional value	-100~100	%	This parameter is updated if vertical axis mode of real-time auto tuning is valid.
6	08	Positive direction torque compensation value	-100~100	%	This parameter is updated if friction compensation mode of real-time auto tuning is valid.
6	09	Negative direction torque compensation value	-100~100	%	This parameter is updated if friction compensation mode of real-time auto tuning is valid.

The real-time auto tuning function updates the following basic gain setting parameters in accordance with Pr0.03 "Selection of machine stiffness at realtime auto-gain tuning" For details, refer to 7) Basic gain parameter settings table.

Category	No.	Parameter	Setup range	Unit	Function
1	00	1st gain of position loop	0~30000	0.1/s	If hardness setting is valid, update the setting values in accordance with hardness.
1	01	1st gain of velocity loop	1~32767	0.1 Hz	If hardness setting is valid, update the setting values in accordance with hardness.
1	02	1st time constant of velocity loop integration	1~10000	0.1 ms	If hardness setting is valid, update the setting values in accordance with hardness.
1	04	1st time constant of torque filter	0~2500	0.01 ms	If hardness setting is valid, update the setting values in accordance with hardness.
1	05	2nd gain of position loop	0~30000	0.1/s	If hardness setting is valid, update the setting values in accordance with hardness.
1	06	2nd gain of velocity loop	1~32767	0.1 Hz	If hardness setting is valid, update the setting values in accordance with hardness.
1	07	2nd time constant of velocity loop integration	1~10000	0.1 ms	If hardness setting is valid, update the setting values in accordance with hardness.
1	09	2nd time constant of torque filter	0~2500	0.01 ms	If hardness setting is valid, update the setting values in accordance with hardness.

Specify fixed values for the following parameters for real-time auto tuning.

Category	No.	Parameter	Setup range	Unit	Function
1	03	1st filter of speed detection	0~5	—	If fixed parameter setting is valid, specify "0."
1	08	2nd filter of speed detection	0~5	—	If fixed parameter setting is valid, specify "0."
1	10	Velocity feed forward gain	0~1000	0.1%	If fixed parameter setting is valid, specify "300" (30%).
1	11	Velocity feed forward filter	1~6400	0.01 ms	If fixed parameter setting is valid, set "50" (0.5 ms).
1	12	Torque feed forward gain	0~1000	0.1%	If fixed parameter setting is valid, specify "0."
1	13	Torque feed forward filter	0~6400	0.01 ms	If fixed parameter setting is valid, specify "0."

(Continued)

Specify the following parameters for real-time auto tuning in accordance with gain switching settings.

Category	No.	Parameter	Setup range	Unit	Function
1	14	2nd gain setup	0~1	—	Specify "0" for other cases than maintaining current settings.
1	15	Mode of position control switching	0~10	—	If gain switching is valid, specify "10." If gain switching is invalid, specify "0."
1	16	Delay time of position control switching	0~10000	0.1 ms	Specify "50" for other cases than maintaining current settings.
1	17	Level of position control switching	0~20000	—	Specify "50" for other cases than maintaining current settings.
1	18	Hysteresis at position control switching	0~20000	—	Specify "33" for other cases than maintaining current settings.
1	19	Position gain switching time	0~10000	0.1 ms	Specify "33" for other cases than maintaining current settings.

5) Usage

Control parameters are specified automatically if a value other than "0" is specified for Pr0.02 "Real-time auto-gain tuning setup" in accordance with Pr0.03 "Selection of machine stiffness at realtime auto-gain tuning"

Input an operation command after the drive has been enabled by Servo On. If estimation load characteristic is successful, Pr0.04 "Inertia ratio" is updated. In addition, some mode setting may cause changes of Pr6.07 "Torque command additional value", Pr6.08 "Positive direction torque compensation value", and Pr6.09 "Negative direction torque compensation value".

Specifying higher settings for Pr0.03 "Selection of machine stiffness at realtime auto-gain tuning" can increase response of motor. Adjust to the optimum value while monitoring the positioning stabilization time and vibration conditions.

6) Other cautions

- ① Strange noises or vibrations may occur on the first action of turning on the servo immediately after startup or setting higher value of Pr0.03 "Selection of machine stiffness at realtime auto-gain tuning" until estimation of load characteristic becomes stable. This is not a fault if the function becomes stable soon. If oscillation or continued generation of abnormal noise through three or more reciprocating movements often occurs, take the following steps.
 - 1) Specify lower value for Pr0.03 "Selection of machine stiffness at realtime auto-gain tuning"
 - 2) Specify "0" for Pr0.02 "Real-time auto-gain tuning setup" and make real-time auto tuning invalid.
 - 3) Specify a theoretical value of device for Pr0.04 "Inertia ratio" and specify "0" for Pr6.07 "Torque command additional value", Pr6.08 "Positive direction torque compensation value", and Pr6.09 "Negative direction torque compensation value".
- ② After occurrence of strange noises or vibrations, values of Pr0.04 "Inertia ratio," Pr6.07 "Torque command additional value", Pr6.08 "Positive direction torque compensation value", or Pr6.09 "Negative direction torque compensation value" may have been changed into extreme values. If this is the case, take Step 3) above.
- ③ The results of real-time automatic gain tuning, such as Pr0.04 "Inertia ratio," Pr6.07 "Torque command additional value", Pr6.08 "Positive direction torque compensation value", and Pr6.09 "Negative direction torque compensation value" are written in EEPROM in every 30 minutes. Upon restarting of power, auto tuning is performed using the data for initial values. The results of real-time auto gain tuning are not stored if the power is turned off before 30 minutes have elapsed. In this case, manually write the parameters to the EEPROM before turning off the power.
- ④ The control gain is updated when the motor is stopped. Therefore, if motor is not stopped because gain is excessively low or commands are given continually in one direction, the change in Pr0.03 "Real-time auto-tuning machine stiffness setup" may not be reflected. In this case, abnormal sound or oscillation may be generated depending on the stiffness setting that is reflected after the motor stops.

After the stiffness setting is changed, be sure to stop the motor and check that the stiffness setting is reflected before performing next operation.

7) Basic gain parameter settings table

Stiffness	Gain 1				Gain 2				A4 Series stiffness setting (Reference) *1
	Pr1. 00	Pr1. 01	Pr1. 02	Pr1. 04 *2	Pr1. 05	Pr1. 06	Pr1. 07	Pr1. 09 *2	
	Position [0.1/s]	Speed [0.1 Hz]	Velocity integral [0.1 ms]	Torque [0.01 ms]	Position [0.1/s]	Speed [0.1 Hz]	Velocity integral [0.1 ms]	Torque [0.01 ms]	
0	20	15	3700	1500	25	15	10000	1500	
1	25	20	2800	1100	30	20	10000	1100	
2	30	25	2200	900	40	25	10000	900	
3	40	30	1900	800	45	30	10000	800	
4	45	35	1600	600	55	35	10000	600	
5	55	45	1200	500	70	45	10000	500	
6	75	60	900	400	95	60	10000	400	
7	95	75	700	300	120	75	10000	300	
8	115	90	600	300	140	90	10000	300	0
9	140	110	500	200	175	110	10000	200	
10	175	140	400	200	220	140	10000	200	
11	320	180	310	126	380	180	10000	126	1
12	390	220	250	103	460	220	10000	103	2
13	480	270	210	84	570	270	10000	84	3
14	630	350	160	65	730	350	10000	65	4
15	720	400	140	57	840	400	10000	57	5
16	900	500	120	45	1050	500	10000	45	6
17	1080	600	110	38	1260	600	10000	38	7
18	1350	750	90	30	1570	750	10000	30	8
19	1620	900	80	25	1880	900	10000	25	9
20	2060	1150	70	20	2410	1150	10000	20	10
21	2510	1400	60	16	2930	1400	10000	16	11
22	3050	1700	50	13	3560	1700	10000	13	12
23	3770	2100	40	11	4400	2100	10000	11	13
24	4490	2500	40	9	5240	2500	10000	9	14
25	5000	2800	35	8	5900	2800	10000	8	
26	5600	3100	30	7	6500	3100	10000	7	15
27	6100	3400	30	7	7100	3400	10000	7	
28	6600	3700	25	6	7700	3700	10000	6	
29	7200	4000	25	6	8400	4000	10000	6	
30	8100	4500	20	5	9400	4500	10000	5	
31	9000	5000	20	5	10500	5000	10000	5	

*1 Hardness settings of A4 series refers to the setting values (0 to 15) of A4 series parameter Pr22 "Real-time auto tuning machine hardness selection."

*2 For 2500[p/r] encoder, a value is limited to 25, a maximal value.

5-1-2 Adaptive Filter

Vibrations are reduced by estimating resonance frequency on the basis of vibration components appearing in motor speeds under actual operations, and by removing the resonance components from torque command.

1) Scope of application

This function is enabled under the following conditions

Conditions for the functioning of adaptive filter	
Control mode	Control mode must be that other than torque control mode.
Other	<ul style="list-style-type: none"> · In servo On status. · Factors other than control parameters, such as prohibition of deviation counter clearing command input and torque limiter, are appropriately specified and normal motor rotation is possible with no problems.

2) Cautions

The adaptive filter may not function normally in the following conditions. If that happens, manually configure the notch filters for suppressing resonance.

Conditions that interfere with operations of adaptable filter	
Resonance point	<ul style="list-style-type: none"> · When a resonance frequency is lower than 3 times as high as speed responding frequency [Hz]. · The resonance peak is low or control gain is low and its effect is not observed in the motor speed. · Three or more resonance points exist.
Load	<ul style="list-style-type: none"> · Motor speed variation including a high-frequency component is generated due to any nonlinear factor such as backlash.
Command pattern	<ul style="list-style-type: none"> · Acceleration/deceleration is rapid at 30000 [r/min] in 1 [s] or higher.

3) Related parameters

The operation of the adaptive filter can be specified by using the following parameters.

Category	No.	Parameter	Setup range	Unit	Function
2	00	Adaptive filter mode setup	0~4	—	<p>Operating mode of adaptive filter is specified.</p> <p>Setting value 0: Adaptive filter invalid Adaptive filter is Invalid. Current values are retained for parameters related to 3rd and 4th Notch filter.</p> <p>Setting value 1: One adaptive filter is valid. One adaptive filter is made valid. Update parameters related with 3rd Notch filter in accordance with adapting results.</p> <p>Setting value 2: Two adaptive filters are valid. Two adaptive filters are valid. Update parameters related with 3rd and 4th Notch filter in accordance with adapting results.</p> <p>Setting value 3: Resonance frequency measurement mode Resonance frequency is measured. Measurement results are verified on PANATERM. Current values are retained for parameters related to 3rd and 4th Notch filter.</p> <p>Setting value 4: Clearing adapting results. Parameters related to 3rd and 4th Notch filter are made invalid and adapting results are cleared.</p>

(Continued)

The adaptive filter function automatically specifies the following parameters.

Category	No.	Parameter	Setup range	Unit	Function
2	07	3rd Notch frequency	50~5000	Hz	Automatically specifies the first resonance frequency estimated by the adaptive filter function. If no resonance point is found, 5000 is specified.
2	08	3rd notch width selection	0~20	-	This is automatically specified when adaptive filter is valid.
2	09	3rd notch depth selection	0~99	-	This is automatically specified when adaptive filter is valid.
2	10	4th Notch frequency	50~5000	Hz	Automatically specifies the second resonance frequency estimated by the adaptive filter function. If no resonance point is found, 5000 is specified.
2	11	4th notch width selection	0~20	-	This is automatically specified when two adaptive filters are valid.
2	12	4th notch depth selection	0~99	-	This is automatically specified when two adaptive filters are valid.

4) Usage

Input an operating command with a value other than "0" specified for Pr2.00 "Adaptive filter mode setup". If any effect of the resonance point is observed in the motor speed, the parameters for the third and/or fourth notch filters are automatically specified according to the number of adaptive filters.

5) Other cautions

- 1) Abnormal noise or oscillation may be generated immediately after the first Servo On after power-up or after increasing the stiffness setting when real-time auto tuning is enabled until the load characteristics estimation has been stabilized. This is normal if the condition is stabilized soon. If oscillation or continued generation of abnormal noise through three or more reciprocating movements often occurs, take the following steps.
 - 1) Write the parameters with which normal operation has been observed to the EEPROM.
 - 2) Reduce value of Pr0.03 "Selection of machine stiffness at realtime auto-gain tuning"
 - 3) Specify "0" for Pr2.00 "Adaptive filter mode setup" and make adaptive invalid.
 - 4) Manually specify the notch filters.
- 2) After any abnormal noise or oscillation has occurred, the third and fourth notch filter settings may be modified to an extreme value. In that case, make adaptive filter invalid by the procedures of 3) above and specify a setting value "5000" (Invalid) for Pr2.07 "3rd notch frequency" and Pr2.10 "4th notch frequency." Then make the adaptive filter valid again.
- 3) 3rd notch frequency (Pr2.07) and 4th notch frequency (Pr2.10) are written in EEPROM every 30 minutes. The data are used as the initial values for adaptive processing at the next power-up.

5-2 Manual Adjustment

The LIQI series the automatic adjustment function described above. However, if the function is not available due to load conditions or restrictions of operating patterns, or if best responses and stability is needed suitable for device characteristics, manual readjustment may be required.

This section describes the manual tuning function with different subsections for the individual control modes and functions as shown below.

- 1) Position control mode block diagram (5-2-1)
- 2) Gain switching function (5-2-2)
- 3) Notch filter (5-2-3)
- 4) Vibration suppression control (5-2-4)
- 5) Feed forward function (5-2-5)
- 6) 3rd Gain switching function (5-2-6)
- 7) Friction torque compensation (5-2-7)

5-2-1 Block Diagram of Position Control Mode

LIQI series position control has a structure shown in the following block diagram.

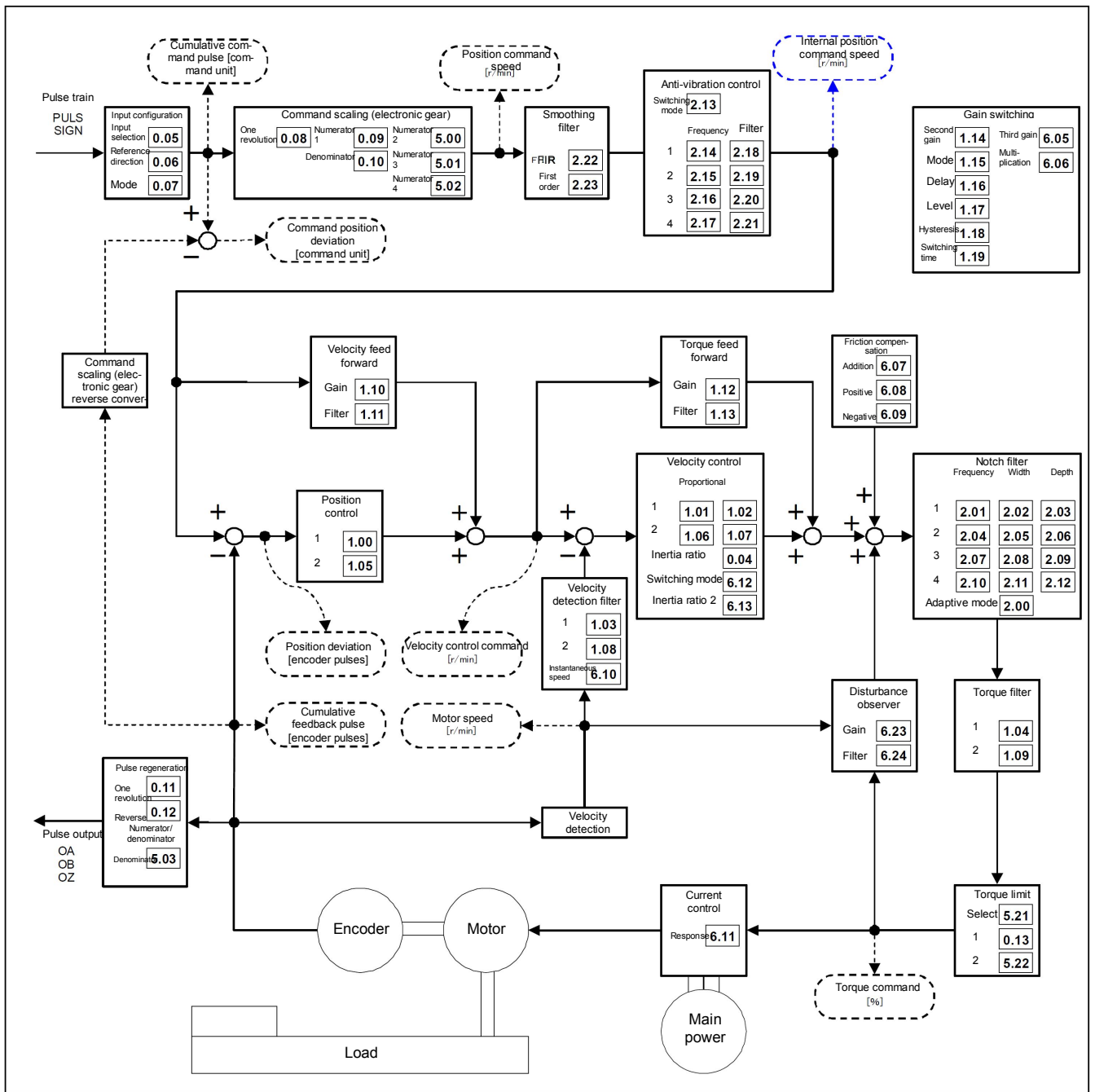

Position control block diagram

5-2-2 Gain Switching Function

Gain switching by internal data or external signals provides the following effects.

- Decreased gain during stop (servo lock) for reducing vibration.
- Increased gain during stop (stabilization) for reducing the stabilization time.
- Increased gain during operation for faster follow-up to command.
- Gain is switched by external signals in accordance with device conditions.

1) Related parameters

The gain switching function can be specified by the following parameters:

Category	No.	Parameter	Setup range	Unit	Function																								
1	14	2 nd gain setup	0~1	-	Specified for optimum tuning by using the gain switching function. 0: Fixed at first gain. The gain switch input (GAIN) is used to switch the speed loop operation between PI and P operations. From GAIN input photocoupler OFF to PI operation From GAIN input photocoupler ON to P operation * The above is the case when the logic setting of GAIN input is connect A. When the logic setting is connect B, OFF and ON are reversed. 1: Gain switching of 1 st gain (Pr1.00 to Pr1.04) and 2 nd gain (Pr1.05 to Pr1.09) is made valid.																								
1	15	Mode of position control switching	0~10	-	Specifies the trigger condition for gain switching in position control. <table border="1"> <thead> <tr> <th>Setting</th> <th>Condition of switching</th> </tr> </thead> <tbody> <tr> <td>0</td> <td>Fixed to the first gain</td> </tr> <tr> <td>1</td> <td>Fixed to the second gain</td> </tr> <tr> <td>2</td> <td>Gain switch</td> </tr> <tr> <td>3</td> <td>Torque command</td> </tr> <tr> <td>4</td> <td>Disabled (fixed to the first gain)</td> </tr> <tr> <td>5</td> <td>Speed command</td> </tr> <tr> <td>6</td> <td>Position deviation</td> </tr> <tr> <td>7</td> <td>Position command</td> </tr> <tr> <td>8</td> <td>Not in-position</td> </tr> <tr> <td>9</td> <td>Actual speed</td> </tr> <tr> <td>10</td> <td>Position command + actual speed</td> </tr> </tbody> </table>	Setting	Condition of switching	0	Fixed to the first gain	1	Fixed to the second gain	2	Gain switch	3	Torque command	4	Disabled (fixed to the first gain)	5	Speed command	6	Position deviation	7	Position command	8	Not in-position	9	Actual speed	10	Position command + actual speed
Setting	Condition of switching																												
0	Fixed to the first gain																												
1	Fixed to the second gain																												
2	Gain switch																												
3	Torque command																												
4	Disabled (fixed to the first gain)																												
5	Speed command																												
6	Position deviation																												
7	Position command																												
8	Not in-position																												
9	Actual speed																												
10	Position command + actual speed																												
1	16	Delay time of position control switching	0~10000	0.1 ms	Specifies the time between trigger detection and actual gain switching from the second to the first gain when the switching mode is 3 or any of 5 - 10 in position control.																								
1	17	Level of position control switching	0~20000	Depends on the mode	Specifies the level of the trigger when the switching mode is 3, 5, 6, 9 or 10 in position control. The unit depends on the switching mode setting. Note) Specify a level \geq Hysteresis.																								
1	18	Hysteresis at position control switching	0~20000	Depends on the mode	Specifies the hysteresis for the trigger when the switching mode is 3, 5, 6, 9 or 10 in position control. The unit depends on the switching mode setting. Note) If a level is lower than hysteresis, hysteresis is set to be the same as level internally.																								
1	19	Position gain switching time	0~10000	0.1 ms	Under position control, if a difference between Pr1.00 "1 st gain of position loop" and Pr1.05 "2 nd gain of position loop" is large, a sudden increase of position loop gain may be suppressed. When position loop gain increases, gains change taking time specified by a setting value.																								

2) Usage

After a gain switching mode for each control mode to use, and make gain switching function valid (Pr1.14=1) by Pr1.14 “2nd gain setup” to use.

Switching mode setting	Condition of switching	Description of gain switching
0	Fixed to the first gain	Fixed to 1 st gain (Pr1.00 to Pr1.04).
1	Fixed to the second gain	Fixed to 2 nd gain (Pr1.05 to Pr1.09).
2	Gain switch	The first gain is used when Gain switch (GAIN) is open. The second gain is used when Gain switch (GAIN) is connected to COM-. * If Gain switch (GAIN) is not assigned to any input signal, the first gain is always used.
3	Torque command	If the previously used first gain has caused the absolute value of the torque command to exceed “Level + Hysteresis” [%], the second gain is used. If the previously used second gain has caused the absolute value of the torque command to stay below “Level – Hysteresis” [%] for the delay time, the first gain is used again.
4	Fixed to the first gain	Fixed to 1 st gain (Pr1.00 to Pr1.04).
5	Speed command	If the previously used first gain has caused the absolute value of the speed command to exceed “Level + Hysteresis” [r/min], the second gain is used. If the previously used second gain has caused the absolute value of the speed command to stay below “Level – Hysteresis” [r/min] for the delay time, the first gain is used again.
5	Speed command	If the previously used first gain has caused the absolute value of the speed command to exceed “Level + Hysteresis” [r/min], the second gain is used. If the previously used second gain has caused the absolute value of the speed command to stay below “Level – Hysteresis” [r/min] for the delay time, the first gain is used again.
7	Position command	If the first gain has been previously used and the position command is not 0, the second gain is used. If the second gain has been previously used and the position command has stayed 0 for the delay time, the first gain is used again.
8	Not in-position	If the previously used first gain has caused incomplete positioning, the second gain is used. If the previously used second gain has caused in-position state to be maintained for the delay time, the first gain is used again.
9	Actual speed	If the previously used first gain has caused the absolute value of the actual speed to exceed “Level + Hysteresis” [r/min], the second gain is used. If the previously used second gain has caused the absolute value of the actual speed to stay below “Level – Hysteresis” [r/min] for the delay time, the first gain is used again.
10	Position command + actual speed	If the first gain has been previously used and the position command is not 0, the second gain is used. If the second gain has been previously used, the position command has stayed 0 for the delay time and the absolute value of the actual speed is below “Level – Hysteresis” [r/min], the first gain is used again.

3) Setting procedures

For example, assume that conditions inside the servo drive changed as shown in the following figure, when the load moved from A position to B position. The following describes the procedures for specifying related parameters when using the gain switching function under those conditions.

① Specify the conditions of switching gains with the following parameters:

Pr1.15 "Mode of position control switching"

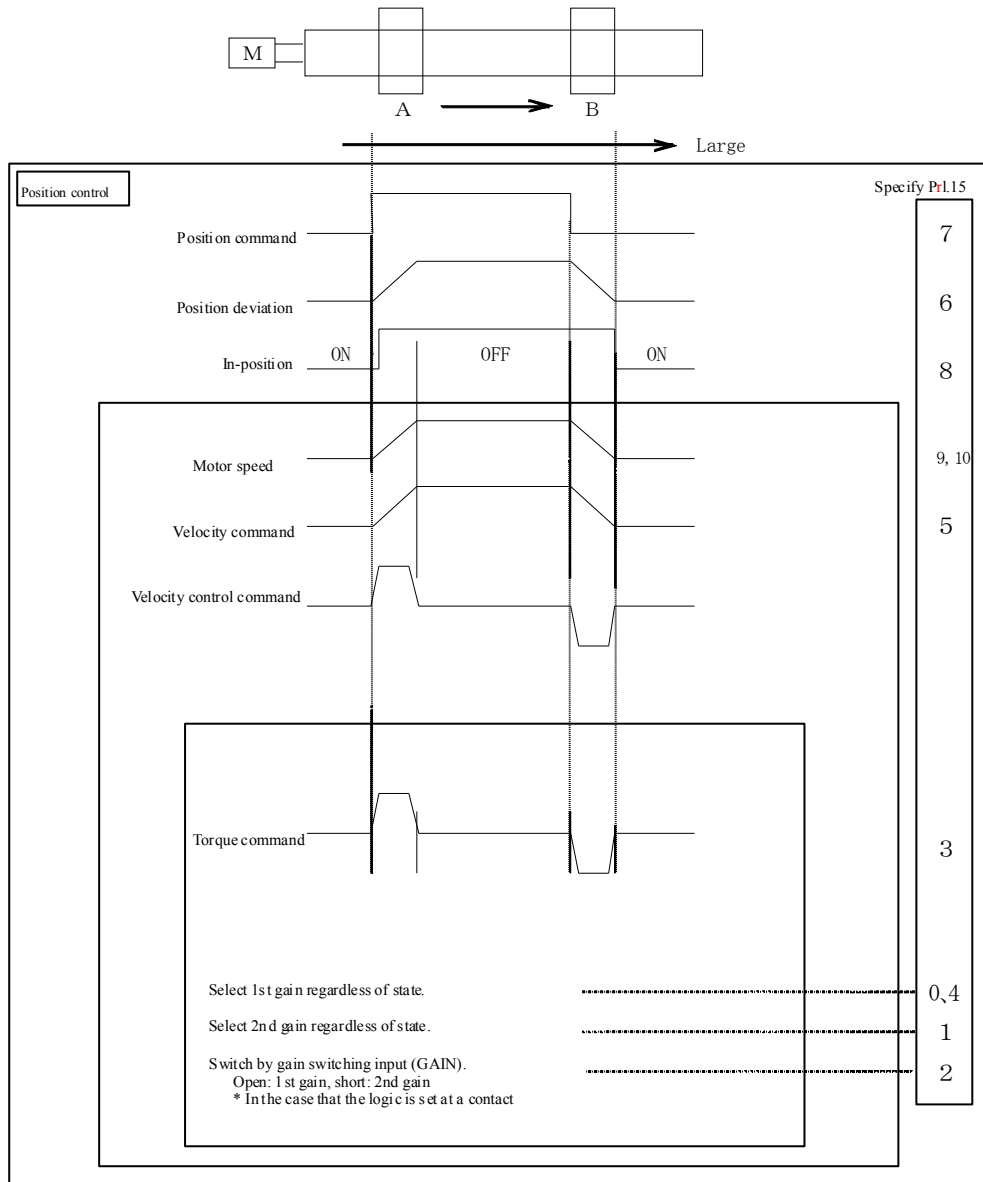

② Specify switching level and hysteresis in accordance with switching conditions.

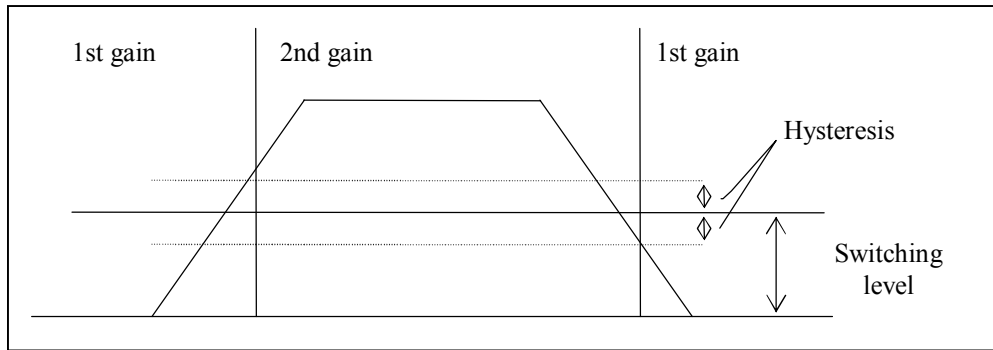

③ Specify switching delay time.

The switching delay time specifies a period of delay time for switching from 2nd gain to 1st gain. When switching from 2nd gain to 1st gain, the switching conditions must be satisfied during a period of switching delay time.

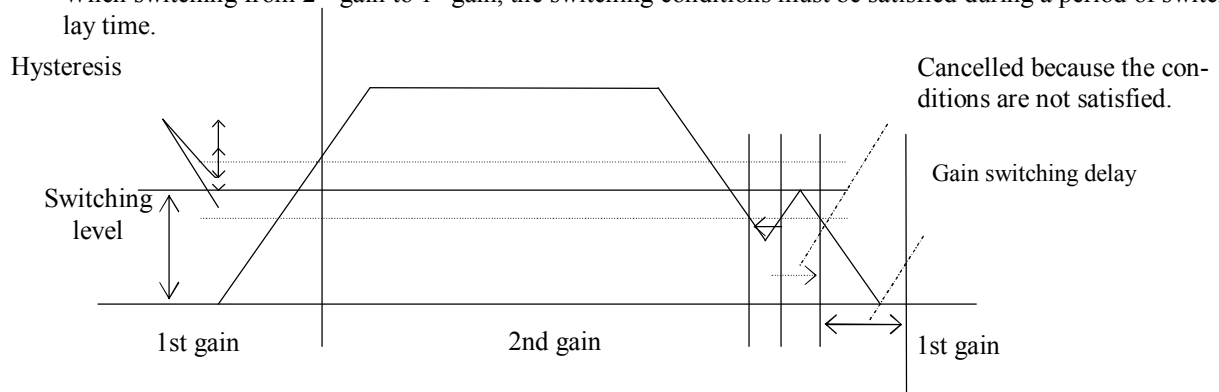

④ Specify position gain switching time

When switching gains, velocity loop gain, speed integration constant, speed detection filter, and torque filtering constant are switched instantaneously. However, position loop gain can be gradually switched to avoid problems caused by sudden change to a high gain.

When “0” is specified for Pr1.19 “Position gain switching time”

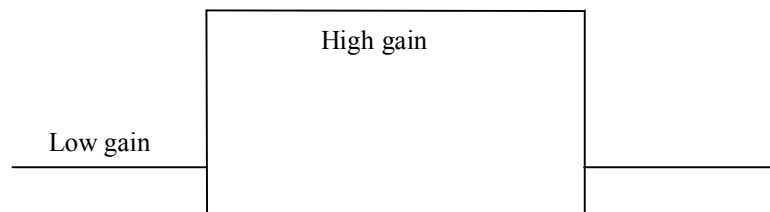

When “5” is specified for Pr1.19 “Position gain switching time”

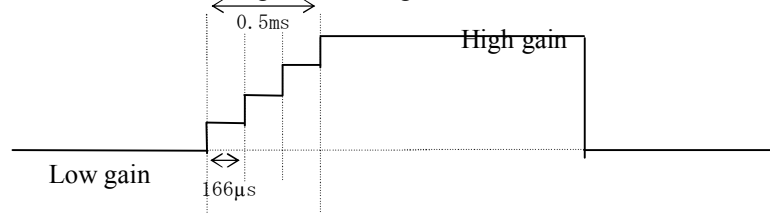

5-2-3 Notch Filter

When the mechanical stiffness is low, resonance due to axis distortion, etc. may generate vibration or noise, in which case a high gain cannot be specified. In that case, specifying a higher gain or reducing vibrations is made possible by suppressing a resonance peak with the notch filter.

1) Related parameter

It is possible to adjust the frequency, width, depth, four related parameters can be used.

Category	No.	Parameter	Setup range	Unit	Function
2	1	1 st Notch frequency	50~5000	Hz	Specifies the center frequency of the first notch filter. Specifying 5000 disables the notch filter.
2	2	1 st notch width selection	0~20	-	Specifies the frequency width of the first notch filter.
2	3	1 st notch depth selection	0-99	-	Specifies the depth at the center frequency of the first notch filter.
2	4	2 nd notch frequency	50~5000	Hz	Specifies the center frequency of the second notch filter. Specifying 5000 disables the notch filter.
2	5	2 nd notch width selection	0~20	-	Specifies the frequency width of the second notch filter.
2	6	2 nd notch depth selection	0~99	-	Specifies the depth at the center frequency of the second notch filter.
2	7	3 rd Notch frequency *1	50~5000	Hz	Specifies the center frequency of the third notch filter. Specifying 5000 disables the notch filter.
2	8	3 rd notch width selection *1	0~20	-	Specifies the frequency width of the third notch filter.
2	9	3 rd notch depth selection *1	0~99	-	Specifies the depth at the center frequency of the third notch filter.
2	10	4 th Notch frequency *1	50~5000	Hz	Specifies the center frequency of the fourth notch filter. Specifying 5000 disables the notch filter.
2	11	4 th notch width selection *1	0~20	-	Specifies the frequency width of the fourth notch filter.
2	12	4 th notch depth selection *1	0~99	-	Specifies the depth at the center frequency of the fourth notch filter.

*1 When the adaptive filter function is used, the parameter value is automatically specified.

2) Usage

Specify a resonance frequency on the basis of the frequency characteristics measurement function of the setup support software, or operating waveform on the waveform graphic function, and specify a Notch frequency for use.

3) Notch width/depth

A value on the left of the following table is specified for a width of Notch filter, which is a ratio of frequency band width in which damping factor becomes -3 [dB] against the Notch center frequency with depth of "0."

The depth of a notch filter is an I/O ratio that provides the complete interruption of the center frequency input with a setting of 0 and complete passage with a setting of 100. In [dB], the values are as shown in the rightmost column of the table below on the right.

Notch width	Bandwidth/Center frequency	
	A4 series (Reference)	
0	0.41	0.50
1	0.56	0.59
2	0.71	0.71
3	0.86	0.84
4	1.01	1.00
5		1.19
6		1.41
7		1.68
8		2.00
9		2.38
10		2.83
11		3.36
12		4.00
13		4.76
14		5.66
15		6.73
16		8.00
17		9.51
18		11.31
19		13.45
20		16.00

Notch depth	I/O ratio	In [dB]
0	0.00	-∞
1	0.01	-40.0
2	0.02	-34.0
3	0.03	-30.5
4	0.04	-28.0
5	0.05	-26.0
6	0.06	-24.4
7	0.07	-23.1
8	0.08	-21.9
9	0.09	-20.9
10	0.10	-20.0
15	0.15	-16.5
20	0.20	-14.0
25	0.25	-12.0
30	0.30	-10.5
35	0.35	-9.1
40	0.40	-8.0
45	0.45	-6.9
50	0.50	-6.0
60	0.60	-4.4
70	0.70	-3.1
80	0.80	-1.9
90	0.90	-0.9
100	1.00	0.0

Depth: 0 / Width: 8

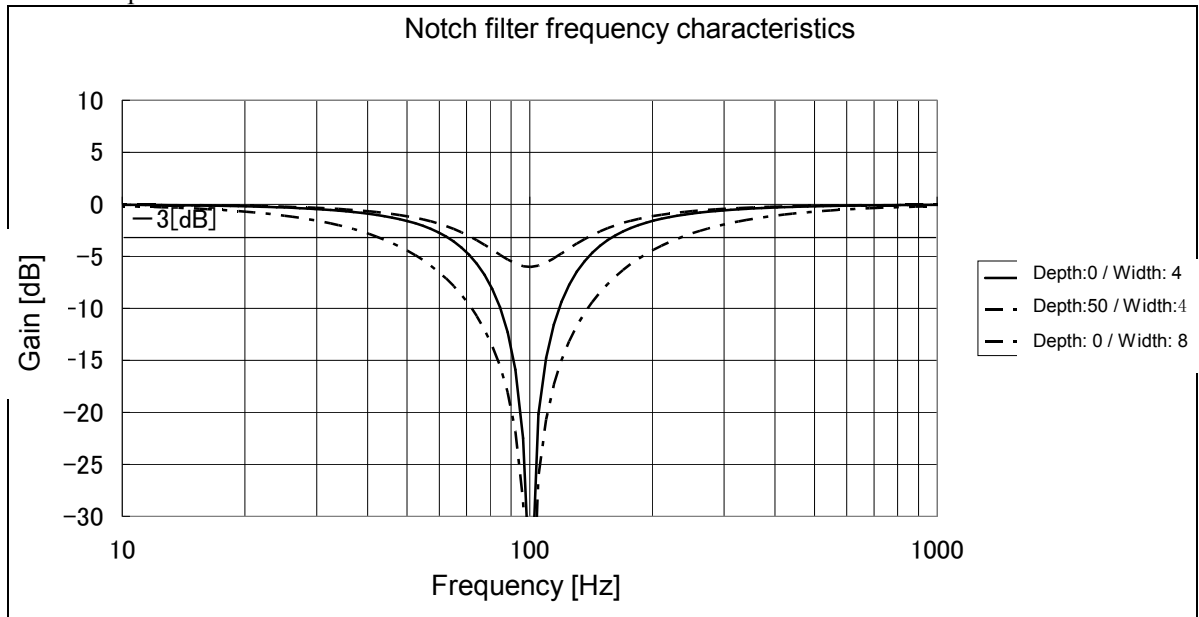

5-2-4 Damping Control

When an end of the equipment vibrates or the entire device shakes, damping control can be used to remove the vibration frequency component from a position command for the reduction of vibration. Of the four frequency settings, up to two can be used simultaneously.

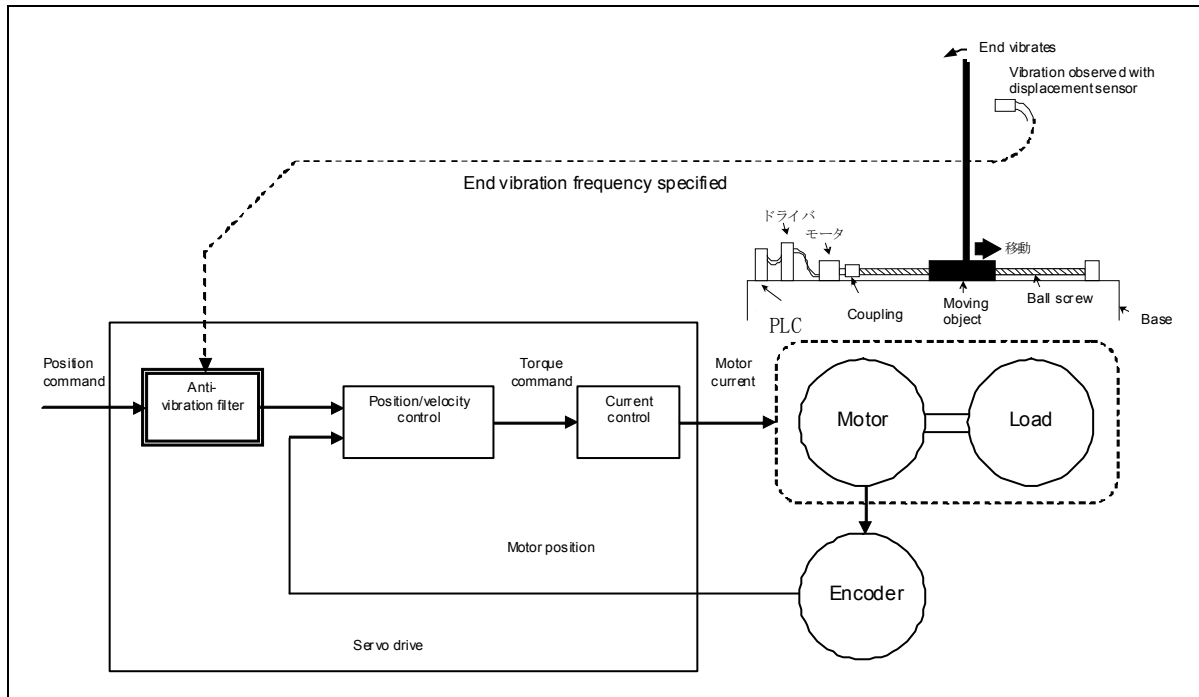

1) Scope of applications

Damping control functions under the following conditions.

Conditions for the functioning of damping control	
Action state	When sub-on, because the input instruction, lead the action shaking.

2) Cautions

Damping control may not function normally or may not be effective in the following conditions.

Conditions hindering the functioning of damping control	
Load condition	<ul style="list-style-type: none"> · Vibration is excited by a factor other than a command (external force, etc.). · The ratio of the resonance frequency to the antiresonance frequency is large. · The vibration frequency is out of the 1.0 - 200.0 [Hz] range. · For the frequency of vibration, the response of the position control is low.

3) Related parameters

The operation of damping control can be specified by using the following parameters.

Category	No.	Parameter	Setup range	Unit	Function																																																																					
2	13	Selection of damping filter switching	0~3	-	Specifying the mode for switching between four filters used for damping control. <ul style="list-style-type: none"> • up to two filters can be used simultaneously. • 1 or 2: switched by external input (VS-SEL1/VS-SEL2) <table border="1"> <thead> <tr> <th>Pr</th> <th>VS-SEL2</th> <th>VS-SEL1</th> <th>1st vibration suppression</th> <th>2nd vibration suppression</th> <th>3rd vibration suppression</th> <th>4th vibration suppression</th> </tr> </thead> <tbody> <tr> <td>0</td> <td>-</td> <td>-</td> <td>Enabled</td> <td>Enabled</td> <td>Invalid</td> <td>Invalid</td> </tr> <tr> <td rowspan="2">1</td> <td>-</td> <td>OFF</td> <td>Enabled</td> <td>Invalid</td> <td>Enabled</td> <td>Invalid</td> </tr> <tr> <td>-</td> <td>ON</td> <td>Invalid</td> <td>Enabled</td> <td>Invalid</td> <td>Enabled</td> </tr> <tr> <td rowspan="4">2</td> <td>OFF</td> <td>OFF</td> <td>Enabled</td> <td>Invalid</td> <td>Invalid</td> <td>Invalid</td> </tr> <tr> <td>OFF</td> <td>ON</td> <td>Invalid</td> <td>Enabled</td> <td>Invalid</td> <td>Invalid</td> </tr> <tr> <td>ON</td> <td>OFF</td> <td>Invalid</td> <td>Invalid</td> <td>Enabled</td> <td>Invalid</td> </tr> <tr> <td>ON</td> <td>ON</td> <td>Invalid</td> <td>Invalid</td> <td>Invalid</td> <td>Enabled</td> </tr> </tbody> </table> <ul style="list-style-type: none"> • 3: switched by direction <table border="1"> <thead> <tr> <th>Pr</th> <th>Position command</th> <th>1st vibration suppression</th> <th>2nd vibration suppression</th> <th>3rd vibration suppression</th> <th>4th vibration suppression</th> </tr> </thead> <tbody> <tr> <td rowspan="2">3</td> <td>Positive</td> <td>Enabled</td> <td>Invalid</td> <td>Enabled</td> <td>Invalid</td> </tr> <tr> <td>Negative</td> <td>Invalid</td> <td>Enabled</td> <td>Invalid</td> <td>Enabled</td> </tr> </tbody> </table>	Pr	VS-SEL2	VS-SEL1	1 st vibration suppression	2 nd vibration suppression	3 rd vibration suppression	4 th vibration suppression	0	-	-	Enabled	Enabled	Invalid	Invalid	1	-	OFF	Enabled	Invalid	Enabled	Invalid	-	ON	Invalid	Enabled	Invalid	Enabled	2	OFF	OFF	Enabled	Invalid	Invalid	Invalid	OFF	ON	Invalid	Enabled	Invalid	Invalid	ON	OFF	Invalid	Invalid	Enabled	Invalid	ON	ON	Invalid	Invalid	Invalid	Enabled	Pr	Position command	1 st vibration suppression	2 nd vibration suppression	3 rd vibration suppression	4 th vibration suppression	3	Positive	Enabled	Invalid	Enabled	Invalid	Negative	Invalid	Enabled	Invalid	Enabled
					Pr	VS-SEL2	VS-SEL1	1 st vibration suppression	2 nd vibration suppression	3 rd vibration suppression	4 th vibration suppression																																																															
					0	-	-	Enabled	Enabled	Invalid	Invalid																																																															
					1	-	OFF	Enabled	Invalid	Enabled	Invalid																																																															
						-	ON	Invalid	Enabled	Invalid	Enabled																																																															
					2	OFF	OFF	Enabled	Invalid	Invalid	Invalid																																																															
						OFF	ON	Invalid	Enabled	Invalid	Invalid																																																															
						ON	OFF	Invalid	Invalid	Enabled	Invalid																																																															
						ON	ON	Invalid	Invalid	Invalid	Enabled																																																															
					Pr	Position command	1 st vibration suppression	2 nd vibration suppression	3 rd vibration suppression	4 th vibration suppression																																																																
3	Positive	Enabled	Invalid	Enabled	Invalid																																																																					
	Negative	Invalid	Enabled	Invalid	Enabled																																																																					
2	14	1 st damping frequency	0~2000	0.1Hz	Specifies the first damping frequency of damping control to suppress vibration of an end of the load. Measure the frequency of the vibration of the load end and specify in increments of 0.1 [Hz]. The effective frequency setting range is 1.0 - 200.0 [Hz]. Specifying 0 - 9 disables the setting.																																																																					
2	15	1 st damping filter setup	0~1000	0.1Hz	Specify a small value if torque saturation has occurred when specified to enable the first damping frequency. Specify a large value for faster operation. Normally, use 0 as the setting. Note) A maximum setting value is internally limited to smaller value of corresponding damping frequency or (2000 - damping frequency).																																																																					
2	16	2 nd damping frequency	0~2000	0.1Hz	Specifies the second damping frequency of damping control to suppress vibration of an end of the load. Measure the frequency of the vibration of the load end and specify in increments of 0.1 [Hz]. The effective frequency setting range is 1.0 - 200.0 [Hz]. Specifying 0 - 9 disables the setting.																																																																					
2	17	2 nd damping filter setup	0~1000	0.1Hz	Specify a small value if torque saturation has occurred when specified to enable the second damping frequency. Specify a large value for faster operation. Normally, use 0 as the setting. Note) A maximum setting value is internally limited to smaller value of corresponding damping frequency or (2000 - damping frequency).																																																																					

*1 1 Switching of damping frequency and damping filter setup is performed during output of positioning completion, and upon starting up command of changing command pulse (before positioning command filtering) from “0” to a value other than “0” for a command pulse detection cycle (0.166 ms).

If damping frequency is particularly high or it is changed to be invalid, and a wide range of positioning completion has been specified, massive amount of residing pulses in the filter (an area found by integrating a value of subtracting position command after filtering from position command before filtering with time) may be suddenly released immediately after switching. Therefore, a sudden action of returning to a correct position may result in temporary rotation of motor faster than originally instructed. Use caution.

*2 There is a delay in applying changed vibration suppression frequencies and damping filter setup to internal calculations. If a switching timing of *1 comes within the delay time, the changes may be suspended.

Category	No.	Parameter	Setup range	Unit	Function
2	18	3 rd damping frequency	0~2000	0.1Hz	Specifies the third damping frequency of damping control to suppress vibration of an end of the load. Measure the frequency of the vibration of the load end and specify in increments of 0.1 [Hz]. The effective frequency setting range is 1.0 - 200.0 [Hz]. Specifying 0 - 9 disables the setting.
2	19	3 rd damping filter setup	0~1000	0.1Hz	Specify a small value if torque saturation has occurred when specified to enable the third damping frequency. Specify a large value for faster operation. Normally, use 0 as the setting. Note) A maximum setting value is internally limited to smaller value of corresponding damping frequency or (2000 - damping frequency).
2	20	4 th damping frequency	0~2000	0.1Hz	Specifies the fourth damping frequency of damping control to suppress vibration of an end of the load. Measure the frequency of the vibration of the load end and specify in increments of 0.1 [Hz]. The effective frequency setting range is 1.0 - 200.0 [Hz]. Specifying 0 - 9 disables the setting.
2	21	4 th damping filter setup	0~1000	0.1Hz	Specify a small value if torque saturation has occurred when specified to enable the fourth damping frequency. Specify a large value for faster operation. Normally, use 0 as the setting. Note) A maximum setting value is internally limited to smaller value of corresponding damping frequency or (2000 - damping frequency).

4) Usage

① Setting of damping frequency (Pr2.14, Pr2.16, Pr2.18, Pr2.20)

Measure the vibration frequency of the end of the load. If it can be directly measured with a laser displacement gauge, etc., read the vibration frequency in increments of 0.1 [Hz] from the measured waveform and specify the value for the parameter.

If a measuring instrument is not available, measure a frequency using the vibration frequency monitor of the setup support software, or using the residing vibrations of position deviation waveform measured with the waveform graphic function.

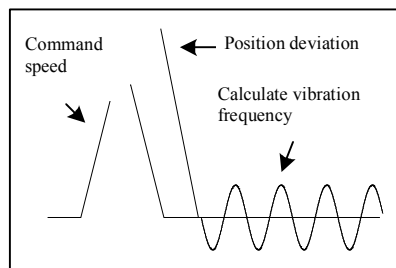

② Setting of damping filter setup (Pr2.15, Pr2.17, Pr2.19, Pr2.21)

Specify 0 first to monitor the torque waveform during operation.

Setting the large value can reduce the stabilization time, but it increases ripple at the command change point as shown in the figure below. Specify the value in the range that does not cause torque saturation in the actual conditions of use. Torque saturation may impair the damping effect.

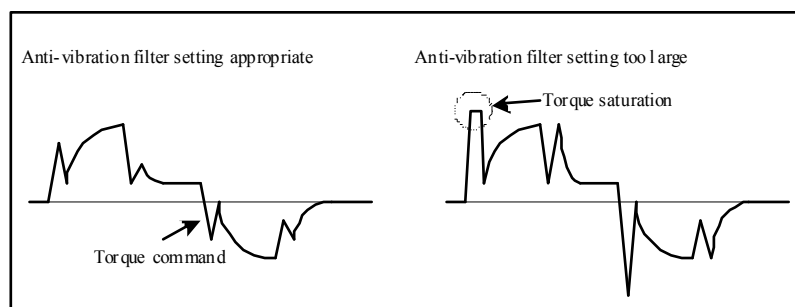

5-2-5 Feed Forward Function

Position deviation can be reduced and response can be improved in comparison with controlling by feedback only, but also using the velocity feed forward function, which calculates speed control command required for operations on the basis of internal position command and adds the calculation to speed control, which is calculated by comparison with position feedback.

The torque feed forward function, which calculates torque command required for operations on the basis of speed control command and adds the calculation to torque command calculated by comparison with speed feedback, improves responses of the speed control system.

1) Related parameters

using two feed forward functions, velocity feed forward and torque feed forward

Category	No.	Parameter	Setup range	Unit	Function
1	10	Velocity feed forward gain	0~1000	0.1%	This adds a value, which is obtained by multiplying a speed control command calculated on the basis of internal position command with a ratio of this parameter, to a speed command from position control process.
1	11	Velocity feed forward filter	0~6400	0.01 ms	A time constant of primary delay filter is specified for inputting to velocity feed forward.
1	12	Torque feed forward gain	0~1000	0.1%	This adds a value, which is obtained by multiplying a torque command calculated on the basis of speed control command with a ratio of this parameter, to a torque command from speed control process.
1	13	Torque feed forward filter	0~6400	0.01 ms	A time constant of primary delay filter is specified for inputting to torque feed forward.

2) Example of using velocity feed forward

Velocity feed forward is made valid by gradually increasing velocity feed forward gain with velocity feed forward filter specified at approximately 50 (0.5 ms). Position deviation during operation at a constant speed becomes smaller as expressed by the following equation, in accordance with a value of velocity feed forward gain.

$$\text{Position deviation [Command unit]} = \frac{\text{Command speed [Command unit/s]} / \text{position loop gain [1/s]} \times (100 - \text{velocity feed forward gain [\%]})}{100}$$

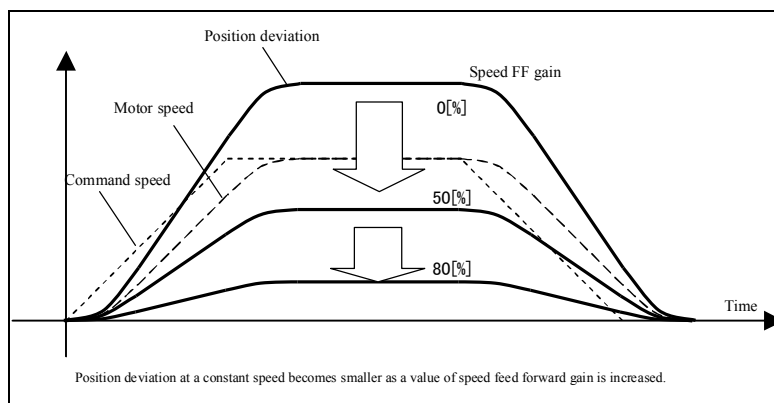

If a gain is specified as 100 [%], position deviation theoretically becomes "0." However, this causes significant overshoot in acceleration and deceleration.

If an updating cycle of position command input is longer than a control cycle of drive, or if pulse frequencies are uneven, operating noise may be louder when velocity feed forward is valid. In that case, use position command filter (Primary delay/FIR smoothing) or specify a higher value for velocity feed forward filter.

3) Example of using torque feed forward

To use torque feed forward, inertia ratio must be specified correctly. Use an estimated value used for operation of real-time auto tuning again, or specify an inertia ratio calculated on the basis of machine specifications for Pr0.04 "Inertia ratio."

Torque feed forward is made valid by gradually increasing torque feed forward gain with torque feed forward filter

specified at approximately 50 (0.5 ms).

Increasing torque feed forward gain can make position deviation closer to “0” under a constant acceleration/deceleration. Therefore, under ideal conditions with no influence from disturbance torque, position deviation can be almost “0” for all operating ranges in operations of a trapezoid speed pattern.

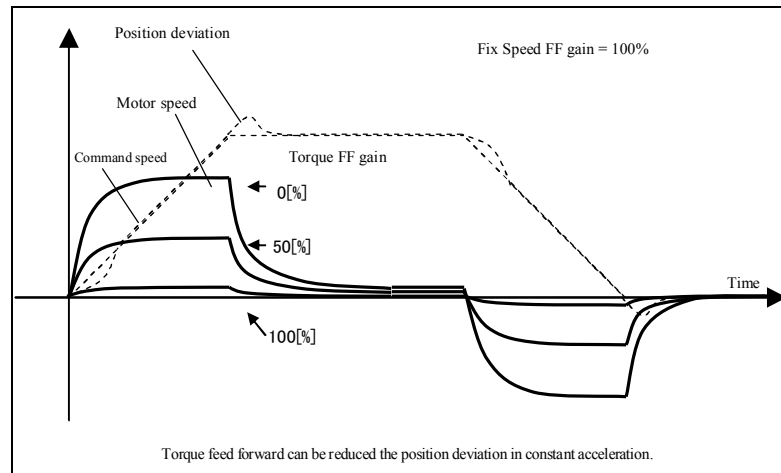

However, under actual conditions, position deviation does not become completely “0” because there is always disturbance torque

Just as the case with velocity feed forward, specifying a larger time constant for torque feed forward filter reduces operating noises. However, it makes position deviation larger at a changing point of acceleration.

5-2-6 3rd Gain Switching

In addition to normal Gain switching function described in Section 5-2-5, specifying 3rd gain is allowed to switch gain just before stopping. By specifying a higher gain for a specified period of time just before stopping, settling time for positioning can be shorter.

(1) Scope of application

□ This function is applicable only when the following conditions are satisfied:

Action state	Conditions for operating 3 rd Gain switching function
	<ul style="list-style-type: none"> · In Servo On status. · Factors other than control parameters such as the deviation counter clear and command pulse inhibition inputs and the torque limit are appropriately configured and do not cause any problem in normal motor rotation.

(2) Related parameters

Category	No.	Parameter	Setup range	Unit	Function
6	05	Position 3 rd gain valid time	0~10000	0.1 ms	Time when 3 rd gain is made valid is specified.
6	06	Position 3 rd gain scale factor	50~1000	%	3 rd gain is specified by magnification against 1 st gain. 3 rd gain=1 st gain×Pr6.06/100

(3) Usage

Specify time of applying 3rd gain in Pr6.05 “Position 3rd gain valid time” under conditions that gain switching function operates normally. Then specify magnification of 3rd gain against 1st gain, in Pr6.06 “Position 3rd gain scale factor”.

- If 3rd gain is not used, specify Pr6.05=0 and Pr6.06=100.
- 3rd gain is valid only under position control/full-closed control.
- In 3rd gain area, 3rd gain is used for position loop gain/speed proportional gain only, and 1st gain setting is used for other areas.
- If 2nd gain switching conditions are satisfied in the 3rd gain area, it switches to 2nd gain.
- Upon switching from 2nd gain to 3rd gain, Pr1.19 “Position gain switching time” is applied.
- Note that switching from 2nd gain to 1st gain by parameter change also makes a 3rd gain area.

Example) In the case of Pr1.15 “Mode of position control switching”=7, switching conditions: with position command

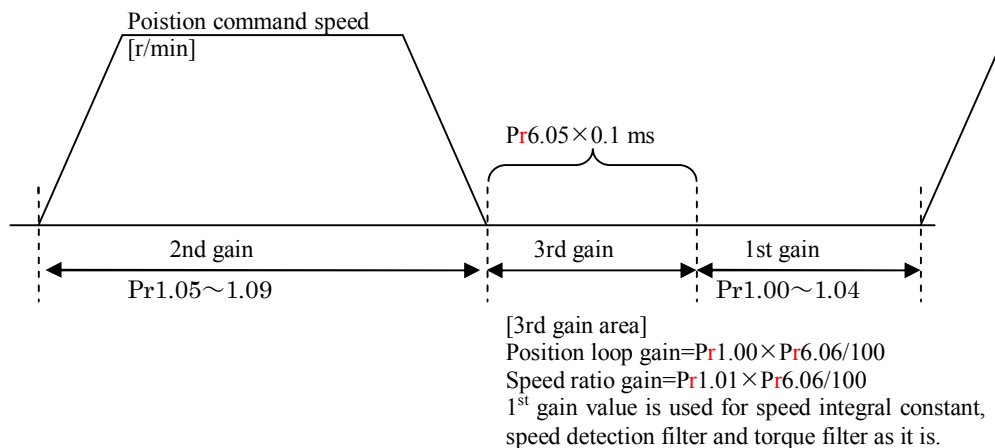

5-2-7 Friction Torque Compensation

Two types of friction torque compensation functions are available for reducing influences from frictions exists in mechanical system: Biased load compensation that compensates offset torque at constant degree, and dynamic friction compensation that changes direction in accordance with operating directions.

(1) Scope of application

□ This function is applicable only when the following conditions are satisfied

	Conditions for operating friction torque compensation
Action state	<ul style="list-style-type: none"> · In Servo On status. · Factors other than control parameters such as the deviation counter clear and command pulse inhibition inputs and the torque limit are appropriately configured and do not cause any problem in normal motor rotation.

(2) Related parameters

Settings of friction torque compensation are specified in combination of the following 3 parameters:

Category	No.	Parameter	Setup range	Unit	Function
6	07	Torque command additional value	-100~100	%	Specify a biased load compensation value, which is always added to torque command in other control modes than torque control.
6	08	Positive direction torque compensation value	-100~100	%	Specify a dynamic friction compensation value, which is added to torque command when normal direction position command is input under position control and full-closed control.
6	09	Negative direction torque compensation value	-100~100	%	Specify a dynamic friction compensation value, which is added to torque command when reverse direction position command is input under position control and full-closed control.

(3) Usage

Friction torque compensation is added in accordance with input position command direction, as show in the following figure:

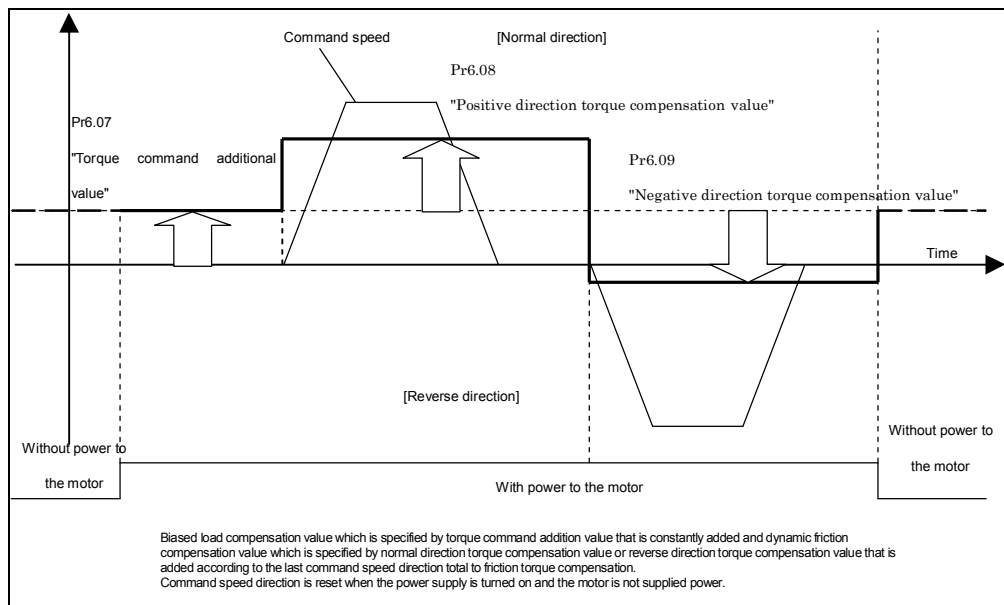

Pr6.07 “Torque command additional value” reduces variations of positioning operations, by specifying a torque command value that may be added as a constant biased load torque applied to a motor due to gravity on vertical axis.

Pr6.08 “Positive direction torque compensation value” and Pr6.09 “Negative direction torque compensation value” prevents prolonging and variations of positioning settling time due to dynamic friction, by specifying friction torques for each rotating direction on parameters, for the loads requiring larger dynamic friction torques due to radial loads, such as belt drive axis.

servo-on status: Current values for biased load compensation and dynamic friction compensation are retained until the first position command is input. At the point of changing from status without position command to status with position command, biased load compensation is updated in accordance with Pr6.07. Also, in accordance with command direction, and in accordance with parameter Pr6.08 or Pr6.09, dynamic friction compensation value is updated.

6. Applied Functions

6-1 Torque Limit Switching

The parameters below have functions to switch torque limit values per the operation direction or with the input of the torque limit switch (TL-SEL).

(1) Scope of application

□ This function is applicable only when the following conditions are satisfied:

	Conditions for operating torque limit switching function
Action state	<ul style="list-style-type: none"> · In Servo On status. · Factors other than control parameters such as the deviation counter clear and command pulse inhibition inputs and the torque limit are appropriately configured and do not cause any problem in normal motor rotation.

(2) Related parameters

Category	No.	Parameter	Setup range	Unit	Function
0	13	1 st torque limit	0~500	%	To set the 1 st limit value of the motor output torque.
5	21	Selection of torque limit	1~3	-	To set up the selecting mode of the torque limit. 1: Normal direction/Reverse direction →Pr0.13 2: Normal direction →Pr0.13, Reverse direction →Pr5.22 3: TL-SEL off →Pr0.13, TL-SEL on →Pr5.22
5	22	2 nd torque limit	0~500	%	To set the 2 nd limit value of the motor output torque.

(3) Description

· The following table shows the torque limit switch modes.

Pr5.21	Torque limit switch input (TL-SEL)	Positive torque limit	Negative torque limit
1	-	Pr0.13	
2	-	Pr0.13	Pr5.22
3	O F F	Pr0.13	
	O N	Pr5.22	

6-2 Motor Movement Range Setting

If the motor travels exceeding the motor working range which is set with Pr5.14 “Motor working range setup” in addition to the position command input range, the software limit protection will make an alarm stop.

The use of this function will prevent collision with the machine end caused by motor oscillation.

(1) Scope of application

□ This function is applicable only when the following conditions are satisfied:

	Conditions for operating motor working range function
Action state	<ul style="list-style-type: none"> · In Servo On status. · Factors other than control parameters such as the deviation counter clear and command pulse inhibition inputs and the torque limit are appropriately configured and do not cause any problem in normal motor rotation.

(2) Cautions

- Note that this function does not provide protection against abnormal position commands
 - If software limit protection works, the device slows down and halts in accordance with Pr5.10 “Sequence at alarm”.

Some loads may contact an edge of device and cause damage. Specify a range for Pr5.14 in consideration of slowing down operations.

- The software limit protection is invalid during the trial run performed via the front monitor and when the frequency characteristics function is used through the communication.

(3) Related parameters

Category	No.	Parameter	Setup range	Unit	Function
5	14	Motor working range setup	0~1000	0.1 revolution	To set the motor working range in addition to the position command input range. Exceeding the value set with this parameter will prompt the software limit protection.

(4) Example of movement:

1) When no position command is entered (with the servo control on)

The motor movable range will be set only by Pr5.14 at both sides of the motor because there is no position command entered. If the load enters the error occurrence range (the lightly shaded area in the figure below) due to vibration and other reasons, the motor movable range protection will be activated.

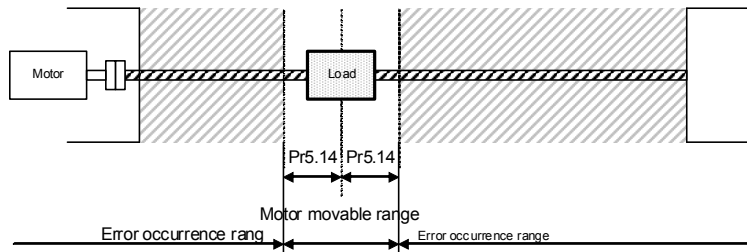

2) When the load moves to the right

Entering a position command to the right will extend the motor movable range accordingly: the total movable range will be the position command input range together with the number of rotations set by Pr5.14 added to the both sides.

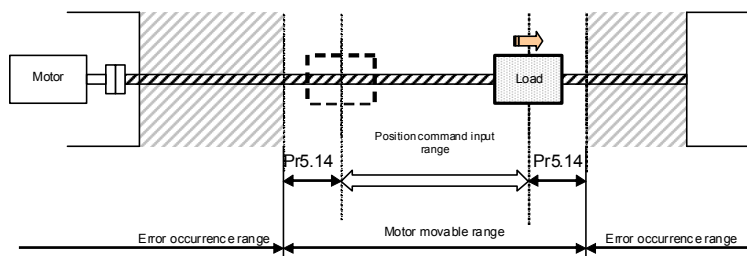

3) When the load moves to the left (with the servo control on)

Entering a position command to the left will further extend the position command input range.

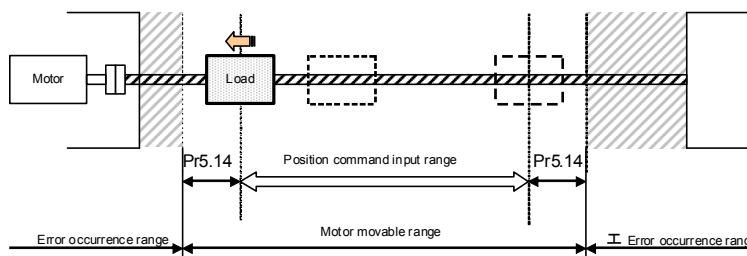

● **Conditions to clear the position command input range**

The following conditions will clear the position command input range to 0:

- The power is turned on
- While a position deviation is being cleared (with the deviation counter clear being valid, and the input of the overtravel limit being valid with Pr5.05 "Sequence at over-travel inhibit" = 2)
- At the start and end of the trial run performed by communication

6-3 Electronic Gear Switching

With the following parameters, it is possible to switch between maximum of 4 numerators of the command scaling by using DIV1 and DIV2.

For the command scaling function, please refer to 4-2-2 “Command Scaling (Electronic Gear).”

(1) Scope of application

□ This function is applicable only when the following conditions are satisfied:

	operating conditions for specified frequency division multiplication switching function
Action state	<ul style="list-style-type: none"> · In Servo On status. · Factors other than control parameters such as the deviation counter clear and command pulse inhibition inputs and the torque limit are appropriately configured and do not cause any problem in normal motor rotation.

(2) Related parameters

Category	No.	Parameter	Setup range	Unit	Function
0	08	Command pulse counts per one motor revolution	0~ 1048576	Pulse	Specifies the command pulse count corresponding to one revolution of the motor. If this setting value is “0” or in full-closed control, Pr0.09 “1 st numerator of electronic gear,” Pr0.10 “Denominator of electronic gear,” Pr5.00 “2 nd numerator of electronic gear”, Pr5.01 “3 rd numerator of electronic gear”, and Pr5.02 “4 th numerator of electronic gear”, are made valid.
0	09	1 st numerator of electronic gear	0~ 1073741824	-	To set the numerator used for the command scaling performed for the command pulse input. Is valid when Pr0.08 “Command pulse counts per one motor revolution “ is 0. For position control, when the value is set to 0, the encoder resolution is set to the numerator. For full-closed control, when the value is set to 0, the command scaling ratio forcibly becomes 1:1.
0	10	Denominator of electronic gear	1~ 1073741824	-	Specifies the denominator for scaling for a command pulse input. Is valid when Pr0.08 “Command pulse counts per one motor revolution “ is 0.
5	00	2 nd numerator of electronic gear	0~ 1073741824	-	To set the 2 nd numerator used for the command scaling performed for the command pulse input. Is valid when Pr0.08 “Command pulse counts per one motor revolution” is 0. For position control, when the value is set to 0, the encoder resolution is set to the numerator. For full-closed control, when the value is set to 0, the command scaling ratio forcibly becomes 1:1.
5	01	3 rd numerator of electronic gear	0~ 1073741824	-	To set the 3 rd numerator used for the command scaling performed for the command pulse input. Is valid when Pr0.08 “Command pulse counts per one motor revolution” is 0. For position control, when the value is set to 0, the encoder resolution is set to the numerator. For full-closed control, when the value is set to 0, the command scaling ratio forcibly becomes 1:1.
5	02	4 th numerator of electronic gear	0~ 1073741824	-	To set the 4 th numerator used for the command scaling performed for the command pulse input. Is valid when Pr0.08 “Command pulse counts per one motor revolution” is 0. For position control, when the value is set to 0, the encoder resolution is set to the numerator. For full-closed control, when the value is set to 0, the command scaling ratio forcibly becomes 1:1.

- The following table shows DIV1 and DIV2, and their corresponding numerators and denominators used for the command scaling.

D I V 1	D I V 2	Command scaling	
		Numerator	Denominator
O F F	O F F	Pr0.09	Pr0.10
O N	O F F	Pr5.00	Pr0.10
O F F	O N	Pr5.01	Pr0.10
O N	O N	Pr5.02	Pr0.10

6-4 Setting of Sequence Movements

A series of actions can be defined for various operation states.

6-4-1 Drive prohibition input (POT , NOT) sequence

The following shows how to prescribe actions taken after an overtravel limit (POT or NOT) is entered.

(1) Related parameters

Category	No.	Parameter	Setup range	Unit	Function
5	04	Over-travel inhibit input setup	0~2	-	Specify drive prohibition input (POT, NOT) input operations. 0: POT →Normal direction drive prohibited, NOT →Functions as reverse direction drive prohibition. If POT is input during normal direction operation, the system halts in accordance with Pr5.05 “Sequence at over-travel inhibit”. For Reverse direction, the system performs the same operation when NOT is input. 1: POT , NOT is invalid and has no effect on operations. 2: Inputting either POT or NOT activates Err38.0 “Over-travel inhibit input protection”.
5	05	Sequence at over-travel inhibit	0~2	-	If Pr5.04 “Over-travel inhibit input setup”= 0, specify status during slowdown and after halting after inputting drive prohibition input (POT, NOT).
5	11	Torque setup for emergency stop	0~500	%	To set a torque limit for the immediate stop.

(2) Item

- Details of Pr5.05 “Sequence at over-travel inhibit”

Pr5.04	Pr5.05	During deceleration *6	After stop	Position deviation/external scale deviation
0	0	Dynamic brake applied	For the overtravel direction, torque command =0	Retained *2
	1	For the overtravel direction, torque command =0	For the overtravel direction, torque command =0	Retained *2
	2	Immediate stop *5	For the overtravel direction, command =0 *1	Cleared before and after the deceleration *3

*1 the position command = 0 is srv-lock

*2 If commands keep coming for the overtravel direction with the overtravel limit on, the position deviations may accumulate to result in Err24.0 “Position deviation excess protection”. In case an overtravel limit is turned on, stop commands for the overtravel direction.

*3 Position deviations/external scale deviations are cleared twice at the start and end of the deceleration; therefore, it is necessary to execute an homing operation to return to origin if the position is being controlled.

*4 If a setting value for Pr5.04 “Over-travel inhibit input setup” is “2,” Err38.0 “Over-travel inhibit input protection” is activated when either POT or NOT is turned on. Therefore, the system operates in accordance with Pr5.10 “Sequence at alarm”, not with this setting value. If other types of errors occur also, Pr5.10 “Sequence at alarm” takes precedence.

*5 “Immediate stop” refers to the control to stop immediately with the servo control on.

Torque command values for that case are restricted by Pr5.11 “Torque setup for emergency stop”.

Because instantaneous stopping slows down a motor suddenly, position deviation of position control becomes larger instantaneously, and it may cause Err24.0 “Position deviation excess protection” or Err34.0 “Software limit protection”. In that case, specify appropriate values for Pr0.14 “Position deviation excess setup” and Pr5.14 “Motor working range setup”.

*6 “During deceleration” refers to the section from the state where the motor is operating until the speed is reduced to 30 r/min or below. Once the speed reduction achieves 30 r/min and thus it transfers to the “After stop” state, the post-stop actions will be performed regardless of the motor speed.

6-4-2 Sequence at Servo Off

This section shows how to define actions taken while the servo control is off.

(1) Related parameters

Category	No.	Parameter	Setup range	Unit	Function
5	06	Sequence at Servo-Off	0~9	—	To set the states during the deceleration and after the stop when the servo control is turned off.
5	07	Main power off action	0~9	-	To define the states during the deceleration and after the stop when the main power is turned off.
5	11	Torque setup for emergency stop	0~500	—	To set a torque limit for the immediate stop.

(2) Item

• Details of Pr5.06 “Sequence at Servo-Off”

Pr5.06	During deceleration *4	After stop	Position deviation/ external scale deviation
0、1	Dynamic brake (DB) applied	Dynamic brake (DB) applied	Clear
2、3	Dynamic brake (DB) applied	Free (DB OFF))	Clear
4、5	Dynamic brake (DB) applied	Dynamic brake (DB) applied	Retained *2
6、7	Dynamic brake (DB) applied	Free (DB OFF)	Retained *2
8	Immediate stop *1	Dynamic brake (DB) applied	Clear *5
9	Immediate stop *1	Free (DB OFF)	Clear*5

• Details of Pr5.07 “Sequence at main power OFF”

Pr5.07	After stop	Position deviation/ex ternal scale deviatio n
0~3、8、9	Dynamic brake (DB) applied	Clear
4~7	Dynamic brake (DB) applied	Retained *2

*1 “Immediate stop” refers to the control to stop immediately with the servo control on.

Torque command values for that case are restricted by Pr5.11 “Torque setup for emergency stop”.

*2 If position commands keep coming or the motor stays running with the main power off, the position deviations may accumulate to result in Err24.0 “Position deviation excess protection”. Also if the servo control is turned on with a significant level of position deviations/external scale deviations, the motor may make an abrupt start in order to perform the control to set the deviations to 0. Use due care when using the system with the position deviations/external scale deviations retained.

*3 If an error occurred with main power supply turned off, the system operates in accordance with Pr5.10 “Sequence at alarm”.

*4 “During deceleration” refers to the section from the state where the motor is operating until the speed is reduced to 30 r/min or below. Once the speed reduction achieves 30 r/min and thus it transfers to the “After stop” state, the post-stop actions will be performed regardless of the motor speed.

*5 Position deviation/External scale deviation is cleared before and after slowing down. They are always cleared to zero after shifting to off-status of main power supply.

*6 Pr5.07「Torque command additional value」 set the offset torque to be added to the torque command. Please take notice of that dynamic brake can't be appointed as decelerating or stopping.

6-4-3 Emergency Stop at Alarm

If an alarm occurs that requires an immediate stop, setting the following parameters will control the motor to immediately stop it.

(1) Related parameters

Category	No.	Parameter	Setup range	Unit	Function
5	10	Sequence at alarm	0~7	—	To set up the states during the deceleration and after the stop when an alarm occurs. The immediate stop is valid when the parameter is set to either 4, 5, 6 or 7.

(2) Item

- Details of Pr5.10 “Sequence at alarm”

Pr5.10	During deceleration *3	After stop	Position deviation/ external scale deviation
0~3	Dynamic brake (DB) applied	Dynamic brake (DB) applied	Cleared *1
4~7	Operation A: Instantaneous stopping Operation B: DB operation *2	Dynamic brake (DB) applied	Cleared *1

- *1 Position deviations/external scale deviations at the time when an alarm occurs will be retained while the alarm is still there, and they will be cleared when the alarm is cleared.
- *2 The selection of the operation A or B shows whether an immediate stop is executed. An alarm that necessitates an immediate stop will prompt the operation A, an immediate stop, if the setting value is 4, 5, 6 or 7. An alarm that does not require an immediate stop will result in the actions specified with the operation B; i.e. either application of the dynamic brake (DB) or free-run. (Refer to section 6-5-5.)

Hold the main circuit power until deceleration stop is completed.

Refer to 7-1 “List of Protective Functions” for alarms that require an immediate stop

- *3 “During deceleration” refers to the section from the state where the motor is operating until the speed is reduced to 30 r/min or below. Once the speed reduction achieves 30 r/min and thus it transfers to the “After stop” state, the post-stop actions will be performed regardless of the motor speed.

6-4-4 Emergency Stop at Alarm

If an alarm occurs that requires an immediate stop, setting the following parameters will control the motor to immediately stop it.

(1) Related parameters

Category	No.	Parameter	Setup range	Unit	Function
5	10	Sequence at alarm	0~7	—	To set up the states during the deceleration and after the stop when an alarm occurs. The immediate stop is valid when the parameter is set to either 4, 5, 6 or 7.
5	11	Torque setup for emergency stop	0~500	%	To set a torque limit for the immediate stop.
5	13	Overspeed level	0~20000	r/min	If the motor speed exceeds the value set with this parameter, Err26.0 “Over-speed protection” occurs. If the value is set to 0, the overspeed level will be set at the maximum number of motor revolution multiplied by 1.2.
6	14	Emergency stop time at alarm	0~1000	ms	To set the allowable time for the immediate stop to complete when there is an alarm. The time exceeding the value set for this parameter will force a state of alarm. If 0 is set for this parameter, the immediate stop doesn't do, and become an alarm state immediately.
6	15	2 nd over-speed level setup	0~20000	r/min	If the motor speed exceeds the value set for this parameter during an immediate stop which has been caused by an alarm, Err26.1 “2 nd over-speed protection” will occur. If the value is set to 0, the overspeed level will be set at the maximum number of motor revolution multiplied by 1.2.

(2) Item

Immediate stop operation when an alarm requiring an immediate stop occurs

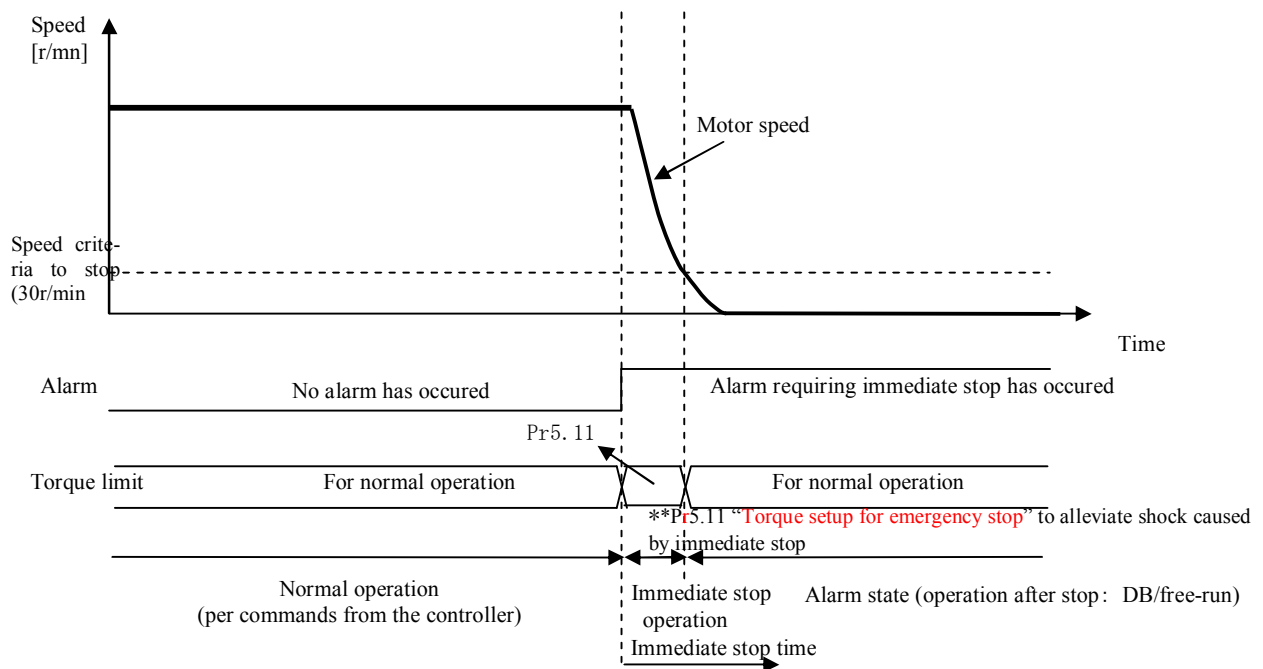

If the time specified by Pr6.14 “Emergency stop time at alarm” has passed since an alarm requiring an immediate stop had occurred and if the actual speed is over 30 r/min, then an alarm state will be prompted immediately. An alarm not applicable to instantaneous stopping in the drive during a fast shutdown immediately leads to alarm state.

(Note) To protect against runaway upon instantaneous stopping, specify an allowable excessive speed level in Pr6.15 “2nd over-speed level setup”. If 2nd excessive speed protection, which is an error not applicable to instantaneous stopping, is activated, it immediately leads to error tripping. However, if set lower than Pr5.13 “Over-speed level setup”, a fast shutdown will not be executed due to Err26.1 “2nd over-speed protection” that occurs before Err26.0 “Over-speed protection”.
If Err26.0 and Err26.1 are detected at the same time, Err26.0 will be displayed but a fast shutdown will not be executed due to Err26.1 that is internally occurring.

7. Protective/Warning Functions

7-1 List of Protective Functions

This servo drive has various integrated protective functions. If any of these functions is activated, the driver will turn off the alarm output signal (ALM) and go into a trip state, showing the error code number in the 7-segment LED at the front panel.

Err code		Alarm	Attribute		
Main	Main		History	History	Immediate stop *5
11	0	Control power supply undervoltage protection	/	○	/
12	0	Over-voltage protection	○	○	/
13	0	Main power supply undervoltage protection (between P to N)	/	○	/
14	0	Over-current protection	○	/	/
	1	IPM error protection	○	/	/
15	0	Over-heat protection	○	/	○
16	0	Over-load protection	○	○*1	/
18	0	Over-regeneration load protection	○	/	○
21	0	Encoder communication disconnect error protection	○	/	/
	1	Encoder communication error protection	○	/	/
23	0	Encoder communication data error protection	○	/	/
24	0	Position deviation excess protection	○	○	○
	1	Velocity deviation excess protection	○	○	○
26	0	Over-speed protection	○	○	○
	1	2 nd over-speed protection	○	○	/
27	0	Command pulse input frequency error protection	○	○	○
	2	Command pulse multiplier error protection	○	○	○
28	0	Limit of pulse replay error protection	○	○	○
29	0	Deviation counter overflow protection	○	○	/
33	0	IF overlaps allocation error 1 protection	○	/	/
	1	IF overlaps allocation error 2 protection	○	/	/
	2	IF input function number error 1 protection	○	/	/
	3	IF input function number error 2 protection	○	/	/
	4	IF output function number error 1 protection	○	/	/
	6	CL fitting error protection	○	/	/
	7	INH fitting error protection	○	/	/
34	0	Motor action range limit protection	○	○	/
36	0 ~2	EEPROM parameter error protection	/	/	/
37	0 ~2	EEPROM check code error protection	/	/	/
38	0	Over-travel inhibit input protection	/	○	/
44	0	Absolute single turn counter error protection / Incremental signal turn counter error protection	○	/	/
45	0	Absolute multi-turn counter error protection / Incremental multi-turn counter error protection	○	/	/
48	0	Incremental Encoder Z-phase error protection	○	/	/
49	0	Incremental Encoder CS signal error protection	○	/	/
87	0	Compulsory alarm input protection	/	○	/
95	0 ~4	Motor automatic recognition error protection	/	/	/
Other numbers		Other error	○	/	/

*1: If Err16.0 “Over-load protection” started to work, it can be canceled about 10 seconds after the occurrence.

*2 : If Err40.0 “Absolute system down error protection” and Err42.0 “Absolute over-speed error protection” occurred, these errors cannot be cleared unless the absolute encoder is cleared.

*3 : If an alarm that can be cleared occurred, you can clear it through the alarm clear input (A-CLR), front panel operation or communication interface. Please execute the alarm clear while stopping without fail after confirming safety.

*4 : If the control circuit within the servo drive has malfunctioned due to reasons such as excessive noise, the following may be displayed.



In such a case, immediately turn off the power.

*5 : A fast shutdown refers to an alarm that causes an immediate stop when Pr5.10 “Sequence at alarm” is set to the value between 4 and 7. Please refer to 6-5-4 “Sequence at Alarm” for details.

7-2 Details of Protective Functions

Protective function		Name	Cause	Action
Main	Sub			
11	0	Control power supply undervoltage protection	<p>The PN voltage at the converter of the control power has reduced to the specified value or less.</p> <p>① The supply voltage is too low. An instantaneous power failure has occurred.</p> <p>② The power supply capacity is too small: the supply voltage has reduced due to rush current when the main power was turned on.</p> <p>③ The servo drive has failed (circuit failure).</p>	<p>Measure the line voltage of L1C-L2C at the connector and terminal block.</p> <p>① Increase the supply voltage capacity. Change the power supply.</p> <p>② Increase the power supply capacity.</p> <p>③ Replace with a new servo drive.</p>
12	0	Over-voltage protection	<p>The supply voltage has exceeded the allowable input voltage range. → The PN voltage at the converter has increased to the specified value or more. The supply voltage is too high. A sudden voltage increase due to a phase advance capacitor and/or UPS (uninterruptible power supply system).</p> <p>① The regenerative resistor has disconnected wires.</p> <p>② The external regenerative resistor is inappropriate, not absorbing regenerative energy.</p> <p>③ The servo drive has failed (circuit failure).</p>	<p>Measure the line voltage of the connectors (L1, L2, and L3). Enter the correct voltage. Remove the phase advance capacitors.</p> <p>① By using a tester, measure the resistance of the resistor externally attached between the terminals B1-B2 of the servo drive. If ∞, there is disconnected wiring.</p> <p>② Change the regenerative resistance and wattage to the specified values.</p> <p>③ Replace with a new servo drive.</p>
13	0	Main power supply undervoltage protection (between P to N)	<p>When Pr5.08 “LV trip selection at main power OFF” is set to 1, instantaneous power failure between L1 and L3 occurred for a longer time than specified in Pr5.09 “Detection time of main power off”, or the P-N voltage of the main power converter decreased below the defined value at servo-on.</p> <p>① The supply voltage is too low. An instantaneous power failure has occurred.</p> <p>② An instantaneous power failure has occurred.</p> <p>③ The power supply capacity is too small: the supply voltage has reduced due to rush current when the main power was turned on.</p> <p>④ Open phase: The servo drive specified with a 3-phase input was operated with a single phase power supply.</p> <p>⑤ The servo drive has failed (circuit failure).</p>	<p>Measure the line voltage of connectors (L1, L2, and L3).</p> <p>① Increase the supply voltage capacity. Change the power supply. Remove the cause for the electromagnetic contactor to have failed, and turn on the power again.</p> <p>② Check the setting of Pr5.09 “Detection time of main power off”. Provide the correct setting for each phase of the power supply.</p> <p>③ Increase the power supply capacity. Refer to “List of peripheral devices applicable to the servo drive” for the capacity of the power supply.</p> <p>④ Make the correct connection for each phase of the power supply (L1, L2, and L3). Use L1 and L3 for single phase 100 V and single phase 200 V.</p> <p>⑤ Replace with a new servo drive.</p>
14	0	Over-current protection	<p>Current flowing in the converter has exceeded the specified value.</p> <p>① The servo drive has failed (such as component failure in circuit and IGBT)</p> <p>② Short circuit of the motor wires U, V, and W</p> <p>③ Ground fault of the motor wires</p> <p>④ Burnout of the motor</p> <p>⑤ Contact failure of the motor wires</p>	<p>① Turn on the servo control with the motor wires disconnected. If the failure occurs immediately, replace the servo drive with a new (operating) one.</p> <p>② Check for whiskers of the connector lead wires to make sure the motor wire connections U, V, and W are not short circuited. Make the correct connection of the motor wires.</p> <p>③ Check the insulation resistance between the motor wires U, V, and W and the motor ground wires. If the insulation is insufficient, replace the motor.</p> <p>④ Check the resistance between the motor wires for balance. If the balance is poor, replace the motor.</p> <p>⑤ Check for any lost connector pin at the motor connections U, V, and W. Fix any loose or lost pins properly.</p>
	1	IPM error protection	<p>⑥ The dynamic brake relay has adhered because the servo control has been turned on and off frequently.</p> <p>⑦ The motor is not suitable for the servo drive.</p> <p>⑧ Timing of the pulse input is either the same as or earlier than that of the servo turning on.</p>	<p>⑥ Change the servo drive. Stop starting and stopping the operation by turning the servo control on and off.</p> <p>⑦ Check the name plates of the motor and servo drive for their part numbers (for the capacity). Replace the motor to fit the servo drive.</p> <p>⑧ Wait for 100 ms at the minimum after the servo control is turned on before entering any pulse.</p>

(Continued)

Protective function		Name	Cause	Action
Main	Sub			
15	0	Over-heat protection	<p>The temperature of the servo drive heat sink and power devices has increased to the specified value or more.</p> <p>① The ambient temperature of the servo drive has exceeded the specified value.</p> <p>② Overload</p>	<p>① Improve the ambient temperature and cooling conditions for the servo drive.</p> <p>② Increase the capacity of the servo drive and motor. Specify a longer acceleration time. Reduce load.</p>
16	0	Over-load protection	<p>Torque command value has exceeded the over-load level specified in Pr5.12 “Over-load level setup” and resulted in overload protection according to the time characteristics.</p> <p>① The load is too heavy, the effective torque has exceeded the rated torque, and the operation continued for too many hours.</p> <p>② Oscillation and hunting due to poor gain tuning. The motor is showing vibration and abnormal noise. The set value specified in Pr0.04 “Inertia ratio” is abnormal.</p> <p>③ The motor wiring is wrong or disconnected</p> <p>④ The machine has collided or suddenly got heavy. The machine has been distorted.</p> <p>⑤ The electromagnetic brake was kept applied.</p> <p>⑥ While making multiple connections, the motor wire was connected to some other axes, resulting in incorrect wiring.</p>	<p>Check the torque (current) curve for oscillation and excessive amplitude by using the analog output or the communication. See the front panel or communication to check for an overload warning indication and load factor.</p> <p>① Increase the capacity of the servo drive and motor. Specify a longer acceleration time. Reduce load.</p> <p>② Redo the gain tuning.</p> <p>③ Connect the motor wires to the wiring diagram. Change the cables.</p> <p>④ Remove the distortion of the machine. Reduce load.</p> <p>⑤ Measure the brake terminal voltage. Release the brake.</p> <p>⑥ Make the correct connection for the motor wires, encoder wires and their axes.</p>
<p>■ Please find the overload time characteristics at the end of this section.</p>				
18	0	Over-regeneration load protection	<p>Regenerative energy has exceeded the capacity of the regenerative resistor.</p> <p>① Regenerative energy generated during the deceleration due to large load inertia has increased voltage at the converter, causing less regenerative resistor energy to be absorbed, resulting in further voltage increase.</p> <p>② Due to high motor revolution, regenerative energy cannot be fully absorbed during the specified deceleration time.</p> <p>③ The operating limit of the external resistor is restricted to 10 % duty.</p>	<p>Check the load factor of the regenerative resistor either with the front panel or by communication. The regenerative resistor should not be used for continuous regenerative braking.</p> <p>① Check the operation patterns (velocity monitor). Check the display for the indication of regenerative resistor load factor and a regeneration over warning. Increase the capacity of the motor and servo drive. Make the deceleration time more gradual. Use an external regenerative resistor.</p> <p>② Check the operation patterns (velocity monitor). Check the display for the indication of regenerative resistor load factor and a regeneration over warning. Increase the capacity of the motor and servo drive. Make the deceleration time more gradual. Decrease the motor revolution. Use an external regenerative resistor.</p> <p>③ Set Pr0.16 to 2.</p>
<p>Important: When specifying 2 for Pr0.16, always provide the external protection such as a thermal fuse, as it will lose the protection for the regenerative resistor, resulting in its possible overheat and burnout.</p>				

(Continued)

Protective function		Name	Cause	Action
Main	Sub			
21	0	Encoder communication disconnect error protection	The communication between the encoder and the servo drive was interrupted a certain number of times, and the disconnection detection function started to work.	Make the correct connection of the encoder wires. Correct any wrong connections of the connector pin.
	1	Encoder communication error protection	The data communication from the encoder is erroneous. The data error is mainly due to noise. The encode wires are connected but there is a communication data error.	<ul style="list-style-type: none"> • Make sure the encoder supply voltage is DC 5 V +/- 5% (4.75- 5.25 V). Bear this in mind especially when the encoder wires are long. • Separate the encoder wires from the motor wires if they are bundled together. • Connect the shield to FG.
23	0	Encoder communication data error protection	The data communication from the encoder is not erroneous, but the data itself is erroneous. The data error is mainly due to noise. The encode wires are connected but there is a communication data error.	<ul style="list-style-type: none"> • Make sure the encoder supply voltage is DC 5 V +/- 5% (4.75- 5.25 V). Bear this in mind especially when the encoder wires are long. • Separate the encoder wires from the motor wires if they are bundled together. • Connect the shield to FG.
24	0	Position deviation excess protection	Position deviation pulses have exceeded the setup of Pr0.14 “Position deviation excess setup” ① The motor operation is not following the command. ② The set value specified in Pr0.14 “Position deviation excess setup” is too small.	1) Check if the motor rotates according to the position command pulse input. Check the torque monitor to see if the output torque has saturated. Perform a gain tuning. Set the upper limit in Pr0.13 “1 st torque limit” and Pr5.24 “Second torque limit setting.” Make the encoder wiring connections to the wiring diagram. Extend the acceleration time. Reduce the load and lower the velocity. 2) Set a greater value in Pr0.14.
	1	Velocity deviation excess protection	The difference (speed deviation) between in-position preset velocity and actual speed exceeded the Pr6.02 “Velocity deviation excess setup”. Note: When in-position preset velocity becomes zero by force, such as the immediate stop because of the command pulse inhibition (INH) and the positive/negative overtravel limit, the speed deviation increases in that moment. Also, the speed deviation increases during startup of in-position preset velocity, so apply a fully flexible setting.	<ul style="list-style-type: none"> • Increase the Pr6.02 setting value. • Make longer the acceleration and deceleration duration of the in-position preset velocity, or improve the following capability with the gain adjustment. • Disallow the velocity deviation excess detection. (Pr6.02=0)
26	0	Over-speed protection	The motor rotational speed has exceeded the set value specified in Pr5.13 “Over-speed level setup”.	<ul style="list-style-type: none"> • Stop giving excessive speed command. • Check the input frequency and scaling ratio for the command pulse. • If there is an overshoot because the gain tuning is poor, redo it.
	1	2 nd over-speed protection	The motor rotational speed has exceeded the set value specified in Pr6.15 “2 nd over-speed level setup”.	<ul style="list-style-type: none"> • Connect the encoder wires to the wiring diagram.
27	0	Command pulse input frequency error protection	The command pulse input frequency has exceeded 1.2 times the value specified in Pr5.32 “Command pulse input maximum setup”.	<ul style="list-style-type: none"> • Check the command pulse input.
	2	Command pulse multiplier error protection	The scaling ratios used to set the Command pulse counts per one motor revolution, the command scaling numerators 1-4, and the denominator of electronic gear are not appropriate.	<ul style="list-style-type: none"> • Check the setting values for the command scaling.
28	0	Limit of pulse replay error protection	The output frequency for pulse regeneration has exceeded the limit value.	<ul style="list-style-type: none"> • Check the set value specified in Pr0.11 “Output pulse counts per one motor revolution” and Pr5.03 “Denominator of pulse output division.” • To disable the detection, set Pr5.33 “Pulse regenerative output limit setup” to 0.

(Continued)

Protective function		Name	Cause	Action
Main	Sub			
29	0	Deviation counter overflow protection	The position deviation value based on the encoder pulse has exceeded 2^{29} (536870912).	<ul style="list-style-type: none"> • Check if the motor runs according to the position command. • Check the torque monitor to see if the output torque has saturated. • Perform a gain tuning. • Set the upper limit in Pr0.13 “1st torque limit” and Pr5.24 “2nd torque limit”. • Make the encoder wiring connections to the wiring diagram.
33	0	IF overlaps allocation error 1 protection	Duplicate assignment of a function to the input signals (SI1, SI2, SI3, SI4, and SI5).	• Correct the function assignment to the connector pins.
	1	IF overlaps allocation error 2 protection	Duplicate assignment of a function to the input signals (SI6, SI7, SI8, SI9, and SI10).	• Correct the function assignment to the connector pins.
	2	IF input function number error 1 protection	Undefined numbers are used for the function assignment of the input signals (SI1, SI2, SI3, SI4, and SI5).	• Correct the function assignment to the connector pins.
	3	IF input function number error 2 protection	Undefined numbers are used for the function assignment of the input signals (SI6, SI7, SI8, SI9, and SI10).	• Correct the function assignment to the connector pins.
	4	IF output function number error 1 protection	Undefined numbers are used for the function assignment of the output signals (SO1, SO2, and SO3).	• Correct the function assignment to the connector pins.
	6	CL fitting error protection	The deviation counter clear function is assigned to an input signal other than SI7.	• Correct the function assignment to the connector pins.
	7	INH fitting error protection	The command pulse inhibition input enable function is assigned to an input signal other than SI10.	• Correct the function assignment to the connector pins.
34	0	Software limit protection	<p>The motor has exceeded the allowable motor operation range specified in Pr5.14 “Motor working range setup” against the position command input range.</p> <p>1) The gain is not appropriate.</p> <p>2) The set value specified in Pr5.14 is too small.</p>	<p>① Verify the gain (the balance between the position loop gain and velocity loop gain) and the inertial ratio.</p> <p>② Set a greater value in Pr5.14. Or, set Pr5.14 to 0 to disable the protection function.</p>
36	0	EEPROM parameter error protection	When the EEPROM was read out when the power was turned on, the data in the parameter storage area was destroyed.	<ul style="list-style-type: none"> • Redo the entire parameter setting. • If the problem persists, there may be a failure. Replace the servo drive with a new one and return the old one to the dealer of the product for investigation (repair).
	1			
	2			
37	0	EEPROM check code error protection	When the EEPROM was read out when the power was turned on, the data that has been confirmed for writing was destroyed.	There may be a failure. Change the servo drive. Return them to the dealer for investigation (and repair).
	1			
	2			
38	0	Over-travel inhibit input protection	<p>When Pr5.04 “Over-travel inhibit input setup” is set to 0, both of the positive/negative-direction drive prohibition inputs (POT /NOT) were turned on.</p> <p>When Pr5.04 is set to 2, either of the positive/negative-direction drive prohibition inputs was turned on.</p>	<ul style="list-style-type: none"> • Check for malfunctions of switches, wires and power supplies connected to the positive/negative overtravel limits. Pay special attention to the power supply (DC 12 - 24 V) to see if it is taking too much time to start.

(Continued)

Protective function		Name	Cause	Action
Main	Sub			
44	0	Absolute single turn counter error protection	The absolute encoder has detected a malfunction of the single turn counter.	Replace the motor.
45	0	Absolute multi-turn counter error protection	The absolute encoder has detected a malfunction of the multi turn counter.	Replace the motor.
48	0	Incremental Encoder Z-phase error protection	Missing pulse of Z-phase of the serial incremental encoder was detected. The encoder has failed.	Replace the motor.
49	0	Incremental Encoder CS signal error protection	CS signal logic error of the serial incremental encoder was detected. The encoder has failed.	Replace the motor.
87	0	Compulsory alarm input protection	Forced alarm input (E-STOP) has been input.	Check the wiring of forced alarm input (E-STOP).
95	0~4	Motor automatic recognition error protection	The motor is not appropriate for the servo drive.	Replace the motor to suit the servo drive.
Other numbers		Other error	The control circuit has malfunctioned due to reasons such as excessive noise. The servo drive's self diagnosis function was performed and something has gone wrong inside the driver.	<ul style="list-style-type: none"> · Turn off the power and turn it on again. · If the error still occurs, you may have a failure. Stop the operation, and replace the motor and/or servo drive. · Return them to the dealer for investigation (and repair).

Note: Use it so that the effective torque stays within the continuous operating range described in “S-T characteristic” of each motor.

For information on “S-T characteristic”, refer to the motor specifications.

7-3 Warning Functions

A warning is generated before the protective function is activated. This allows you to check the status such as an overload in advance.

In principle, a warning will automatically return to the state where it is not issued if the faulty state is corrected. However, the warning state will be kept during latch duration as shown in the following figure. To clear a latched warning before the latch time expires, perform the procedure taken to execute an alarm clear.

(1) Related parameters

Category	No.	Parameter	Setup range	Unit	Function
4	40	Selection of alarm output 1	0~11	-	Selects the warning output by the Warning output 1(WARN1). Set value 0: OR output of all warnings 1 and after: See the following table.
4	41	Selection of alarm output 2	0~11	-	Select the warning output by the Warning output 2(WARN2). Set value 0: OR output of all warnings 1 and after: See the following table.
6	27	Alarm latch time selection	0~10	-	Sets the warning latch time. 0: Infinite latch time 1 to 10: Latch time 1 to 10[s]
6	38	Alarm mask setup	-32768~32767	-	Performs the mask setting for warning detection. If the corresponding bit is set to 1, the corresponding warning detection is disabled.

(2) Warning type

Warning number	Warning	Item	Pr6.27 *1	Pr4.40/Pr4.41 *2	Pr6.38-compatible bit *3
A0	Overload	The load factor has exceeded 85% of the protection level.	○	1	bit7
A1	Regeneration over	The regeneration load factor has exceeded 85% of the protection level.	○	2	bit5
A4	Encoder communication	The count of consecutive encoder communication errors has exceeded the protection level.	○	5	bit4
A6	Oscillation detection warning	Oscillation state was detected.	○	7	bit9
AA	Over heat warning	When the temperature of Amp over the over heat label	○	11	bit11

*1 For “○”, you can set a value between 1 and 10s in Pr6.27 “Alarm latch time selection”, or set no time limit. Battery warnings and life warnings are set with “no time limit.”

*2 Select the warning output by the Warning output signal 1 (WARN1) and Warning output signal 2 (WARN2) using Pr4.40 “Selection of alarm output 1” and Pr4.41 “Selection of alarm output 2”. If set to 0, OR output of all warnings will be output. Also, do not set a value other than the set values listed in the above table.

*3 Each warning detection can be masked using Pr6.38 “Alarm mask setup”. The supported bits are listed in the table. Bit=1 masks the warning detection.

*4 The encoder overheat is effective only during using the 20 bit incremental serial encoder. It becomes invalid for other encoders.

7—4 Protection Function Setting before Gain Adjustment

When carrying out the gain adjustment, you can enjoy the comfortable usage of it by properly setting the parameters below according to the operating condition.

1) Overtravel limit setting

Allows you to proactively avoid a collision at the end by entering the limit sensor signal into the amplifier. Refer to positive/ negative overtravel limit (POT/ NOT) in the interface specification. Also, set up the following parameters related to overtravel limits:

Pr5.04 “Over-travel inhibit input setup”

Pr5.05 “Sequence at over-travel inhibit”

2) Torque limit

The damage can be reduced when a problem, such as equipment’s bite and collision, occurs by restricting the motor’s maximum torque. To uniformly restrict the torque with parameter, set up Pr0.13 “1st torque limit”.

However, when restricted to less than practically necessary torque, be careful that the position deviation excess protection can occur because a overspeed protection due to overshooting or a command delay occurs.

Also, the limited torque state can be externally detected by allocating the torque limited output (TLC) as the interface specification to the output signal.

3) Overspeed protection

When the motor runs at unusual high-speed, Err26.0 “Over-speed protection” is generated.

By default, it is automatically set to 1.2 times of maximum speed [r/min] of the motor used.

When the maximum speed under customer’s operating condition is less than the motor’s maximum speed, set up Pr5.13 “Over-speed level setup” according to the expression below:

Pr5.13 “Over-speed level setup” = $V_{max} \times (1.2 \text{ to } 1.5)$

V_{max} : Motor’s maximum speed [r/min] under the operating condition

The coefficient enclosed in parentheses is a margin for avoiding the frequent occurrence of overspeed protections.

In addition, when making the motor speed slow at initial adjustment, by establishing a value by multiplying the speed by the margin, you can use the value as a protection just in case it turns into an oscillation state.

4) Position deviation excess protection

Err24.0 “Position deviation excess protection” is generated by detecting the excessive deviation between position command and motor position during the position or full closed control.

The excessive position deviation level can be set up in Pr0.14 “Position deviation excess setup”. Also, the detection position can be selected from the command position deviation [pulse (per command basis)] and the encoder position deviation [pulse (per encoder basis)] in Pr5.20 “Position setup unit select”. (Refer to control block diagram)

By default, 100000 [pulse (command unit)] is established.

Because the position deviation in normal operation can change according to working speed and gain setting, set Pr0.14 to the value calculated from the expression below based on the customer’s operating condition.

(τ) Pr5.20=0 (detected by command position deviation)

Note 1: To change the position loop gain K_p , calculate the gain by using the minimum value.

Pr0.14 "Position deviation excess setup" = $V_c/K_p \times (1.2 \text{ to } 2.0)$

V_c : aximum frequency [pulse (command unit)/s] of the position command pulse

K_p : Position loop gain [1/s]

The coefficient enclosed in parentheses is a margin for avoiding the frequent occurrence of position deviation excess protection.

Note 2: To use a position command filter or a damping control, add the value below.

Position command smoothing filter: $V_c \times \text{filtering constant [s]}$

Position command FIR filter: $V_c \times \text{filtering constant [s]} / 2$

damping control: $V_c / (\pi \times \text{damping frequency [Hz]})$

■ Pr5.20=1 (detected by encoder and full closed position deviations):

Pr0.14 "Position deviation excess setup" = $V_e/K_p \times (1.2 \text{ to } 2.0)$

V_e : aximum operating frequency [pulse/s] per encoder or full closed basis

K_p :Position loop gain [1/s]

Note 3: To change the position loop gain K_p , calculate the gain by using the minimum value.

Note 4: When Pr5.20=1, the position command filter or damping control setting does not impact on it.

5) Motor working range

During the position or full closed control, Err34.0 “Software limit protection” is generated by detecting that the motor exceeded the preset position range by more than the rotation amount established in Pr5.14 “Motor working range setup”.

For more information, refer to 6-3 “Motor Movement Range Setting.”

8. Others

8-1 List of parameters

Category 0: Base configuration

Category	No.	Parameter	Unit	Setup range	Function/description	Attribute
0	00	Rotational direction setup	-	0~1	To set the relationship between the command direction and the motor rotation direction. 0: CW as positive direction, 1: CCW as positive direction	Power reset
	02	Real-time auto-gain tuning setup	-	0~6	To select an action mode for the real-time auto tuning.	Always valid
	03	Selection of machine stiffness at realtime auto-gain tuning	-	0~31	To set the machine stiffness when the real-time auto tuning is executed.	Always valid
	04	Inertia ratio	%	0~10000	To set the load inertia ratio to the motor's rotor inertia.	Always valid
	06	Command pulse rotational direction setup	-	0~1	To set the counting direction of the command pulse.	Power reset
	07	Command pulse input mode setup	-	0~3	To specify the command pulse counting mode. 0,2: 90-degree phase difference two-phase pulse 1: Positive direction pulse string+negative direction pulse string 3: Pulse string+symbol	Power reset
	08	Command pulse counts per one motor revolution	pulse	0~2 ³⁰	To define the command pulse counts per one motor revolution .	Power reset
	09	1 st numerator of electronic gear	-	0~2 ³⁰	To set a numerator in case the command scaling function is set with numerator/denominator.	Always valid
	10	Denominator of electronic gear	-	1~2 ³⁰	To set a denominator in case the command scaling function is set with numerator/denominator.	Always valid
	11	Output pulse counts per one motor revolution	P/r	1~262144	To set the output pulse count per motor revolution for phases A and B.	Power reset
	12	Reversal of pulse output logic	-	0~3	To select the phase B logic of pulse regeneration and the output source.	Power reset
	13	1 st torque limit	%	0~500	To set the 1 st torque limit for the motor output torque. Also, parameter value is limited by the maximum torque of the applicable motor.	Always valid
	14	Position deviation excess setup	Command unit	0~2 ²⁷	To set the maximum position deviation. If set to 0, detection of Err24.0 "Position deviation excess protection" is disabled. The unit is as per Pr5.20 "Position setup unit select".	Always valid
16	External regenerative resistor setup	-	0~3	To define the setting for the regenerative resistor.	Power reset	

Category 1: Gain Tuning

Category	No.	Parameter	Unit	Setup range	Function/description	Attribute
1	00	1 st gain of position loop	0.1/s	0~30000	To set the gain for the 1 st position loop.	Always valid
	01	1 st gain of velocity loop	0.1Hz	1~32767	To set the velocity loop proportional gain 1.	Always valid
	02	1 st time constant of velocity loop integration	0.1ms	1~10000	To set the velocity loop integral time constant 1. Becomes invalid if setting value is 10000.	Always valid
	03	1 st filter of speed detection	-	0~5	To select the velocity detection filter 1 out of 6 preset steps.	Always valid
	04	1 st time constant of torque filter	0.01ms	0~2500	To set the time constant for the torque filter 1.	Always valid
	05	2 nd gain of position loop	0.1Hz	0~30000	To set the second speed proportional gain.	Always valid
	06	2 nd gain of velocity loop	0.1Hz	1~32767	To set the velocity loop proportional gain 2.	Always valid
	07	2 nd time constant of velocity loop integration	0.1ms	1~10000	To set the velocity loop integral time constant 2. Becomes invalid if setting value is 10000.	Always valid
	08	2 nd filter of speed detection	-	0~5	To select the velocity detection filter 2 out of 6 preset steps.	Always valid
	09	2 nd time constant of torque filter	0.01ms	0~2500	To set the time constant for the torque filter 2.	Always valid
	10	Velocity feed forward gain	0.1%	0~1000	To set the velocity feed forward gain.	Always valid
	11	Velocity feed forward filter	0.01ms	0~6400	To set the time constant of the velocity feed forward filter.	Always valid
	12	Torque feed forward gain	0.1%	0~1000	To set the torque feed forward gain.	Always valid
	13	Torque feed forward filter	0.01ms	0~6400	To set the torque feed forward filter.	Always valid
	14	2 nd gain setup	-	0~1	To set this parameter to carry out an optimum tuning by using the function to switch gains.	Always valid
	15	Mode of position control switching	-	0~10	To select the gain switching condition for the position control.	Always valid
	16	Delay time of position control switching	0.1ms	0~10000	To set the delay time when switching from the second gain to the first gain.	Always valid
	17	Level of position control switching	-	0~20000	To set the gain switching level.	Always valid
	18	Hysteresis at position control switching	-	0~20000	To set the gain switching hysteresis.	Always valid
19	Position gain switching time	0.1ms	0~10000	To set the gain switching time of the position loop gain.	Always valid	

Category 2: Damping filter

Category	No.	Parameter	Unit	Setup range	Function/description	Attribute
2	00	Adaptive filter mode setup	-	0-4	Set the adaptive filter mode.	Always valid
	01	1 st notch frequency	Hz	50~5000	To set the notch frequency for the 1 st resonance suppressing notch filter. Match it to the machine's resonance frequency.	Always valid
	02	1 st notch width selection	-	0~20	Sets the notch width for the first resonance prevention notch filter.	Always valid
	03	1 st notch depth selection	-	0~99	To set the notch depth for the 1 st resonance suppressing notch filter.	Always valid
	04	2 nd notch frequency	Hz	50~5000	To set the notch frequency for the 2 nd resonance suppressing notch filter. Match it to the machine's resonance frequency.	Always valid
	05	2 nd notch width selection	-	0~20	To set the notch width for the 2 nd resonance suppressing notch filter.	Always valid
	06	2 nd notch depth selection	-	0~99	To set the notch depth for the 2 nd resonance suppressing notch filter.	Always valid
	07	3 rd notch frequency	Hz	50~5000	To set the notch frequency for the 3 rd resonance suppressing notch filter. Match it to the machine's resonance frequency. This will be set automatically when the adaptive notch is valid.	Always valid
	08	3 rd notch width selection	-	0~20	To set the notch width for the 3 rd resonance suppressing notch filter. This will be set automatically when the adaptive notch is valid.	Always valid
	09	3 rd notch depth selection	-	0~99	To set the notch depth for the 3 rd resonance suppressing notch filter. This will be set automatically when the adaptive notch is valid.	Always valid
	10	4 th notch frequency	Hz	50~5000	To set the notch frequency for the 4 th resonance suppressing notch filter. Match it to the machine's resonance frequency. This will be set automatically when the adaptive notch is valid.	Always valid
	11	4 th notch width selection	-	0~20	To set the notch width for the 4 th resonance suppressing notch filter. This will be set automatically when the adaptive notch is valid.	Always valid
	12	4 th notch depth selection	-	0~99	To set the notch depth for the 4 th resonance suppressing notch filter. This will be set automatically when the adaptive notch is valid.	Always valid
	13	Selection of damping filter switching	-	0~3	To select the switching method in case damping filters are switched.	Always valid
	14	1 st damping frequency	0.1Hz	0~2000	To set the 1 st damping frequency to be used for the damping control to suppress vibration at the end of the load. This will be valid with the setting value at 10 (= 1 Hz) or greater.	Always valid
	15	1 st damping filter setup	0.1Hz	0~1000	To fine-tune the 1 st damping control function. Use a small setting value if a torque saturation is generated; a large setting value if response needs to be raised.	Always valid
	16	2 nd damping frequency	0.1Hz	0~2000	To set the 2 nd damping frequency to be used for the damping control to suppress vibration at the end of the load. This will be valid with the setting value at 10 (= 1 Hz) or greater.	Always valid
	17	2 nd damping filter setup	0.1Hz	0~1000	To fine-tune the 2 nd damping control function. Use a small setting value if a torque saturation is generated; a large setting value if response needs to be raised.	Always valid
	18	3 rd damping filter setup	0.1Hz	0~2000	To set the 3 rd damping frequency to be used for the damping control to suppress vibration at the end of the load. This will be valid with the setting value at 10 (= 1 Hz) or greater.	Always valid
	19	3 rd damping filter setup	0.1Hz	0~1000	To fine-tune the 3 rd damping control function. Use a small setting value if a torque saturation is generated; a large setting value if response needs to be raised.	Always valid
	20	4 th damping frequency	0.1Hz	0~2000	To set the 4 th damping frequency to be used for the damping control to suppress vibration at the end of the load. This will be valid with the setting value at 10 (= 1 Hz) or greater.	Always valid
	21	4 th damping filter setup	0.1Hz	0~1000	To fine-tune the 4 th damping control function. Use a small setting value if torque is saturated; a large setting value if response needs to be raised.	Always valid
	22	Positional command smoothing filter	0.1ms	0~10000	To set the time constant of the 1 st order filter for the position command.	Always valid
23	Positional command FIR filter	0.1ms	0~10000	To set the time constant of the FIR filter for the position control.	Always valid	

Category 3: (none)

Category 4: I/O & Monitor

Category	No.	Parameter	Unit	Setup range	Function/description	Attribute
4	00	SI1 input selection	-	0-0FFFFFFh	To set the function and logic of SI1.	Powerreset
	01	SI2 input selection	-	0-0FFFFFFh	To set the function and logic of SI2.	Powerreset
	02	SI3 input selection	-	0-0FFFFFFh	To set the function and logic of SI3.	Powerreset
	03	SI4 input selection	-	0-0FFFFFFh	To set the function and logic of SI4.	Powerreset
	04	SI5 input selection	-	0-0FFFFFFh	To set the function and logic of SI5.	Powerreset
	05	SI6 input selection	-	0-0FFFFFFh	To set the function and logic of SI6.	Powerreset
	10	SO1 output selection	-	0~0FFFFFF Fh	To assign a function to the SO1.	Powerreset
	11	SO2 output selection	-	0~0FFFFFF Fh	To assign a function to the SO2.	Powerreset
	12	SO3 output selection	-	0~0FFFFFF Fh	To assign a function to the SO3.	Powerreset
	31	Positioning complete (In-position) range	Command unit	0-262144	To set the allowable number of pulses in the positioning complete signal (INP). The unit is as per Pr5.20 "Position setup unit select".	Always valid
	32	Positioning complete (In-position) output setup	-	0-3	To select the criteria for the in-position output.	Always valid
	33	INP hold time	ms	0-30000	To set the INP hold time.	Always valid
	34	Zero-speed	R/min	10~20000	To set the threshold to detect the zero speed (ZSP).	Always valid
	36	At-speed (Speed arrival)	r/min	10~20000	To set the threshold to detect the at-speed (AT-SPEED).	Always valid
	37	Mechanical brake action at stalling setup	ms	0~10000	To set the stop time mechanical brake operation setting. The established resolution is 2ms. For example, if the setting value = 11, it will be 12ms.	Always valid
	38	Mechanical brake action at running setup	ms	0~10000	To set the run time mechanical brake operation setting. The established resolution is 2ms. For example, if the setting value = 11, it will be 12ms.	Always valid
	39	Brake release speed setup	r/min	30-3000	To set the speed threshold for run time mechanical brake output determination.	Always valid
	40	Selection of alarm output 1	-	0~10	To select the warning type for the warning 2 to output.	Always valid
	41	Selection of alarm output 2	-	0~10	To select the warning type for the warning 2 to output.	Always valid
	42	2 nd Positioning complete (In-position) range	Command unit	0~262144	Sets the allowable number of pulses in the positioning complete signal 2(INP2). The unit is as per Pr5.20 "Position setup unit select".	Always valid

Category 5: Extended configuration

Category	No.	Parameter	Unit	Setup range	Function/description	Attribute
5	00	2 nd numerator of electronic gear	-	0~2 ³⁰	Sets the numerator of the second command division.	Always valid
	01	3 rd numerator of electronic gear	-	0~2 ³⁰	Sets the numerator of the third command division.	Always valid
	02	4 th numerator of electronic gear	-	0~2 ³⁰	Sets the numerator of the the fourth command division.	Always valid
	03	Denominator of pulse output division	-	0~262144	Set this when the output pulse counts per one motor revolution should be determined based on the ratio of the numerator to the denominator of the division.	Power reset
	04	Over-travel inhibit input setup	-	0~2	Sets the operation of the positive/negative drive prohibition inputs.	Power reset
	05	Sequence at over-travel inhibit	-	0~2	Sets the sequence during drive prohibition input.	Power reset
	06	Sequence at Servo-Off	-	0~9	Sets the sequence at servo-off.	Always valid
	07	Sequence at main power OFF	-	0~9	Sets the sequence at main power OFF	Always valid
	10	Sequence at alarm	-	0~7	To set the sequence at alarm .	Always valid
	11	Torque setup for emergency stop	%	0~500	To set the torque limit at the immediate stop. When the setting value = 0, the torque limit during normal operation is applied.	Always valid
	12	Over-load level setup	%	0~500	Sets the overload level. If set to 0, the value is 115%. Also, the internal values are limited by 115%.	Always valid
	13	Over-speed level setup	r/min	0~20000	Sets the detection level for Err26.0 “Over-speed protection”. If set to 0, the value is the maximum number of motor rotation multiplied by 1.2. Also, the internal values are limited by the maximum number of motor rotation multiplied by 1.2.	Always valid
	14	Motor working range setup	0.1 revolution	0~1000	To set the maximum travel distance of the motor in addition to the position command.	Always valid
	15	I/F reading filter	-	0~3	Selects the signal read cycle for control input. 0:0.166ms,1:0.333ms,2:1ms,3:1.666ms However, the deviation counter clear input (CL) and command pulse prohibition input (INH) are excluded.	Power reset
	16	Alarm clear input setup	-	0~1	Selects the recognition time for the alarm clear input (A-CLR). 0:120ms 1: As per Pr5.15 “I/F reading filter”.	Power reset
	17	Counter clear input mode	-	0~4	Selects the reception condition for the counter clear input signal. 0: Disabled 1: Clear by level (without reading filter) 2: Clear by level (with reading filter) 3: Clear by edge (without reading filter) 4: Clear by edge (with reading filter)	Always valid
	18	Invalidation of command pulse inhibit input	-	0~1	Enables/disables the command pulse prohibition input (INH). 0: Enabled 1: Disabled	Always valid
	19	Command pulse inhibit input reading setup	-	0~4	Selects the signal read cycle for the command pulse prohibition input (INH). 0:0.166ms,1:0.333ms,2:1ms,3:1.666ms, 4: No read filter	Power reset
	20	Position setup unit select	-	0~1	To define the unit for the in-position range and the Position deviation excess protection . 0: Per command 1: Per encoder	Power reset
	21	Selection of torque limit	-	0~6	To define the mode to select positive/negative torque limits.	Always valid
22	2 nd torque limit	%	0~500	To set the 2 nd torque limit for the motor output torque. Also, parameter value is limited by the maximum torque of the motor used.	Always valid	
32	Command pulse input maximum setup	Kpulse/s	250~4000	Set the maximum number of command pulse inputs to be used. If the command pulse input frequency exceeds this range, Err27.0 “Command pulse input frequency error protection” will occur. Note) Detection of the command pulse input frequency error is performed against the pulses received by the drive. If the pulse frequency input significantly exceeds this set value, detection may not work correctly.	Power reset	
33	Pulse regenerative output limit setup	-	0~1	Enables/disables the detection of Err28.0 “Limit of pulse replay error protection”. 0: Invalid 1: Valid	Power reset	

Category 6: Specific Configuration

Category	No.	Parameter	Unit	Setup range	Function/description	Attribute
6	02	Velocity deviation excess setup	r/min	0~20000	Set up the threshold in Err24.1 "Velocity deviation excess protection". When the setting value = 0, the detection of velocity deviation excess protection will be invalid.	Always valid
	05	Position 3 rd gain valid time	0.1ms	0~10000	To set the valid time for the 3 rd gain of the 3 gain switching steps.	Always valid
	06	Position 3 rd gain scale factor	%	50~1000	To set the scaling factor for the 3 rd gain with the factor used for the 1 st gain.	Always valid
	07	Torque command additional value	%	-100~100	To set the offset torque to be added to the torque command.	Always valid
	08	Positive direction torque compensation value	%	-100~100	To set the value added to the torque command during the operation in the positive direction.	Always valid
	09	Negative direction torque compensation value	%	-100~100	To set the value added to the torque command during the operation in the negative direction.	Always valid
	14	Emergency stop time at alarm	ms	0~1000	To set the allowable time for the immediate stop to complete when there is an alarm. The established resolution is 2ms. For example, if the setting value = 11, it will be 12ms.	Always valid
	15	2 nd over-speed level setup	r/min	0~20000	If the motor speed exceeds the value set for this parameter during an immediate stop caused by an alarm, it will bring the 2 nd over-speed protection state.	Always valid
	18	Power-up wait time	0.1s	0~100	To set the initialization time when the power is turned on by adding time to the standard 1.5 s+a.	Power reset
	27	Alarm latch time selection	s	0~10	Sets the warning latch time. 0: Infinite latch time 1 to 10: Latch time 1 to 10[s]	Power reset
	31	Real time auto tuning estimation speed	-	0~3	To set the estimated speed of load characteristics when the real time auto-gain tuning is valid.	Always valid
	37	Oscillation detection level	0.1%	0~1000	Sets the threshold for oscillation detection. If detecting the torque vibration exceeding this setting, an oscillation detection warning will occur.	Always valid
38	Alarm mask setup	-	-32768~32767	Performs the mask setting for warning detection. If the corresponding bit is set to 1, the corresponding warning detection is disabled.	Power reset	

8-2 Timing Chart

8-2-1 Timing Chart of Operations After Turning Power On

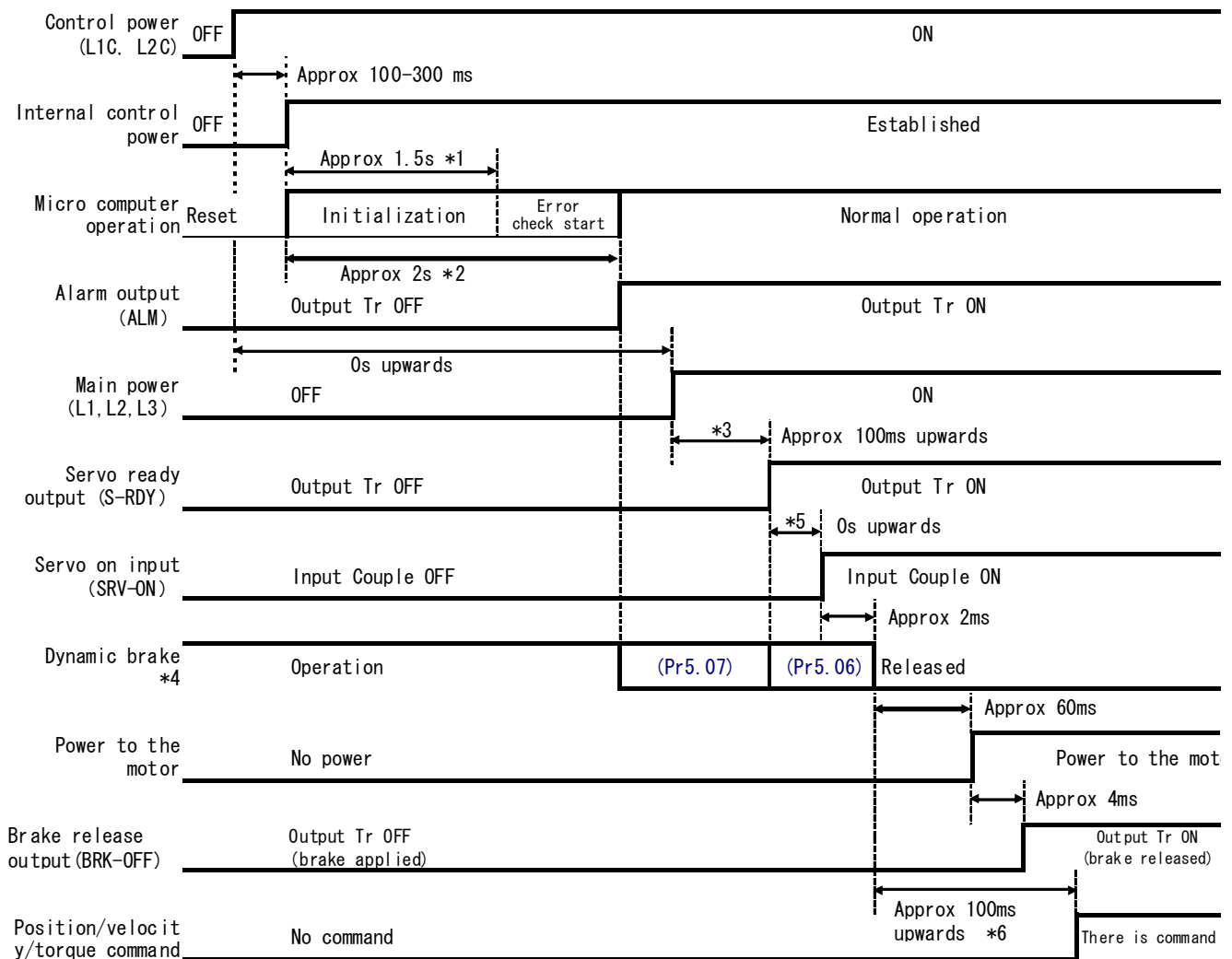

- The above chart shows the timing of actions from the time when the control power is turned on until a command is entered.

Enter the servo-on signal and the position/velocity/torque commands according to the above chart.

- *1. When the internal control power has been established, the protective functions get activated approximately 1.5 s after the start of the micro computer initialization. To design your system, keep in mind that all the input/output signals connected to the driver should be established before the protective functions start getting activated; use special care for signals that can trigger the protective functions such as positive/negative overtravel limits and external scale input. Also, this time can be extended using Pr6.18 "Power-up wait time"
- *2. After microcomputer initializing, and no error, the output of ALM is on.
- *3. S-RDY output is turned on only when the two conditions are met: initialization of the microcomputer has been complete, and the main power has been established.
- *4. As SRV-OFF, until initialize ending, dynamic brake action is according to Pr5.07 "Sequence at main power OFF", after main power establish, according to Pr5.06 "SRV-OFF sequence".
- *5. After the output of SRV-READY is affirmed, please start the input of SRV-ON.
- *6. The signal of SRV-ON from on to the fact of position instruction, the waiting time please set about 100ms at least. Because from SRV-ON to the fact of power to motor need to consume some time, it is possibility the position command can't be accepted.

8-2-2 Timing Chart of Servo On/Off When Monitor is Turned Off
 (For normal operations, stop the motor before turning the servo control on and off)

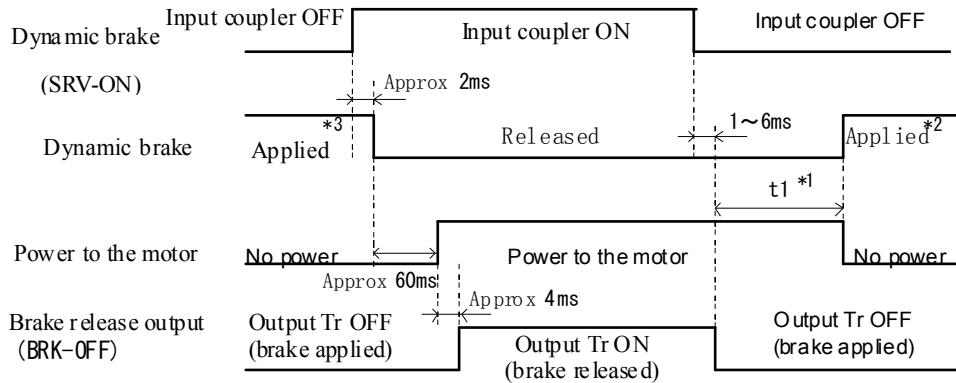

- *1. $t1$ depends on the set value specified in Pr4.37 “Mechanical brake action at stalling setup”.
- *2. The dynamic brake operation at servo-off depends on the set value specified in Pr5.06 “Sequence at servo-off”
- *3. The servo control is not turned on until the motor speed is approximately 30 r/min or less

8-2-3 Timing Chart of Servo On/Off When Motor is Operating
 (This chart shows the timing for the emergency stop and trip. It is not intended for repeated use.)

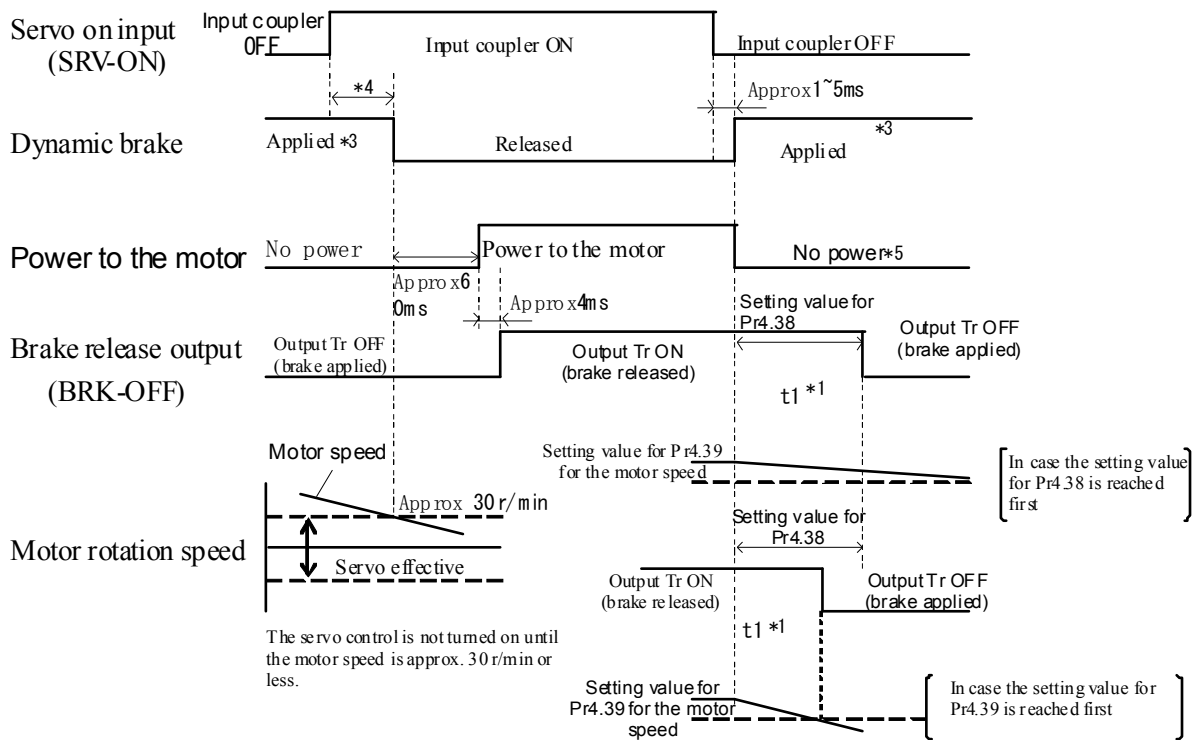

- *1. The time $t1$ will be either the value used to set Pr4.38 “Mechanical brake action at running setup” or when the motor speed is reduced to the setting for Pr4.39 “Brake release speed setup” or less, whichever comes first.
- *2. If the SRV-ON signal is turned on again during the deceleration of the motor, the servo control does not transfer to the servo-on state until the motor stops.
- *3. The operation of the dynamic brake during the servo-off is according to the setting value for Pr5.06 “Sequence at servo-off”.
- *4. The servo control is not turned on until the motor speed is approximately 30 r/min or less.
- *5. Whether electricity is turned on to the motor during the servo-off deceleration depends on the value used to set Pr5.06 “Sequence at servo-off”

8—2—4 Timing Chart of Operations When Alarm is Issued (Servo-On Command Status)

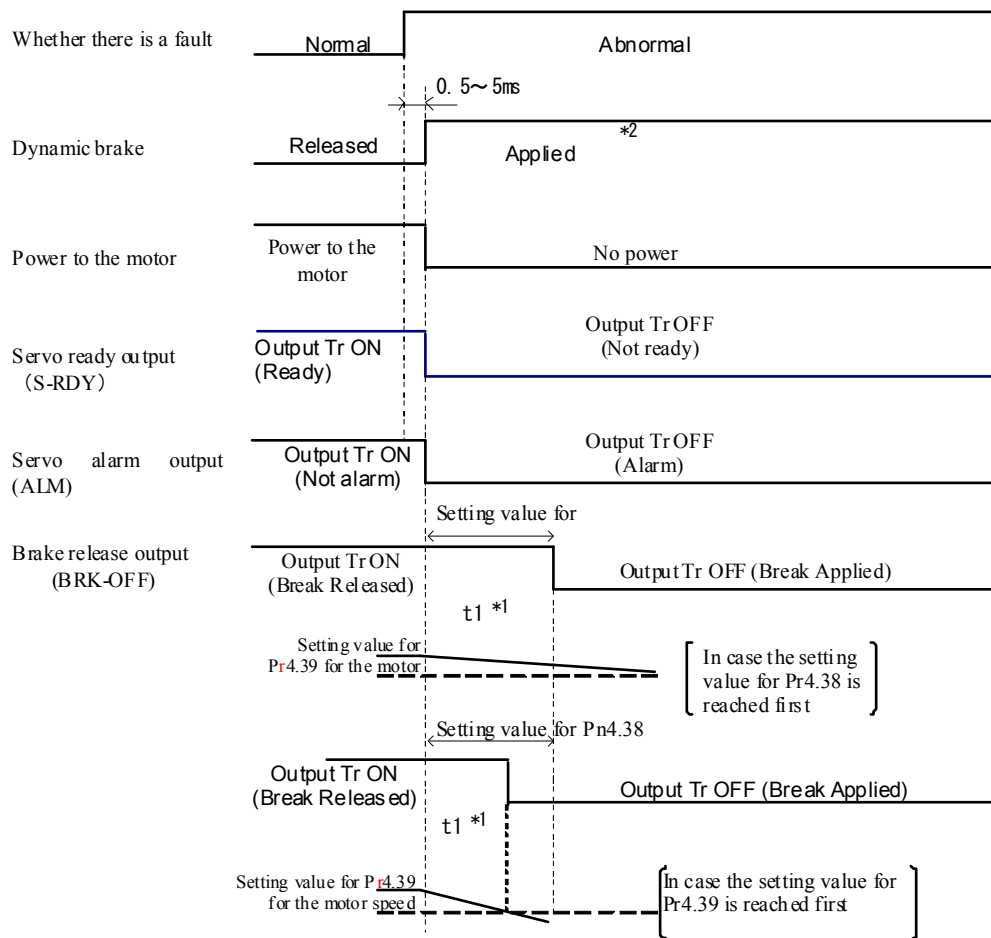

- *1. The time t1 will be either the value used to set Pr4.38 “Mechanical brake action at running setup” or when the motor speed is reduced to the setting for Pr4.39 “Brake release speed setup” or less, whichever comes first.
- *2. The operation of the dynamic brake when an alarm has occurred is according to the setting value for Pr5.10 “Sequence at alarm”.

8—2—5 Timing Chart of Operations When Alarm is Cleared (Servo-On Command Status)

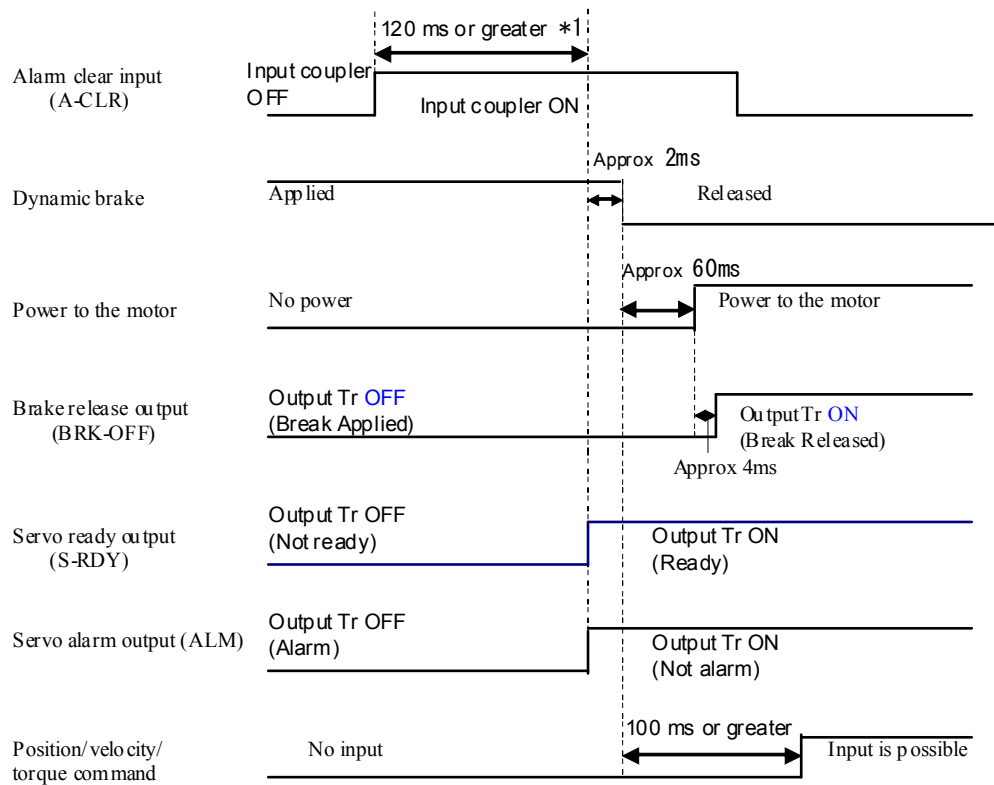

*1. The time to recognize the alarm clear input can be changed with Pr5.16 “Alarm clear input setup”.
(The default setting is 120 ms.)