

GN 119.3 | Cam latches with handle

Recessed key, zinc alloy



- 1
- 2
- 3
- 4
- 5
- 6
- 7
- 8
- 9
- 10
- 11
- 12
- 13
- 14
- 15
- 16
- 17
- 18

HANDLE

Die-cast zinc alloy.
Rotor, latch cam, screw, washer, spring washer and nut M22x1.5 in zinc-plated steel. Distance element in aluminium.

STANDARD EXECUTIONS

- **GN 119.3-DK**: with triangular groove for key.
- **GN 119.3-VK7**: with square 7 groove for key.
- **GN 119.3-VDE**: with two-wing groove for key.
- **SW index**: handle in RAL 9005 black colour.
- **SR index**: handle in RAL 9006 grey colour.

PACKING RING

NBR synthetic rubber.

KEYS (TO BE ORDERED SEPARATELY)

- Die-cast zinc alloy with epoxy resin coating, RAL 9005 black colour, matte finish.
- With triangular groove, GN 119.2-86-DK7-SW (code GN.38701).
 - With square 7x7 groove, GN 119.2-86-VK7-SW (code GN 38706).
 - With two-wing groove, GN 119.2-86-VDE5-SW (code GN.38711).

FEATURES AND APPLICATIONS

GN 119.3 handles with latch cams have a pulling-in range of 10 mm. The internal O-ring prevents the ingress of liquids, dust, etc. through the door.

ASSEMBLY INSTRUCTIONS

1. Drill a hole in the door as per the drilling template drawing with the axis at a distance of 23 mm from the door frame.
2. Insert frontally the latch body in the hole of the door and screw on the threaded nut.
3. Insert the distance element and the cam by fitting it by the threaded screw.



GN 119.2

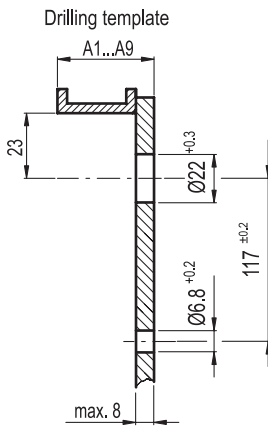

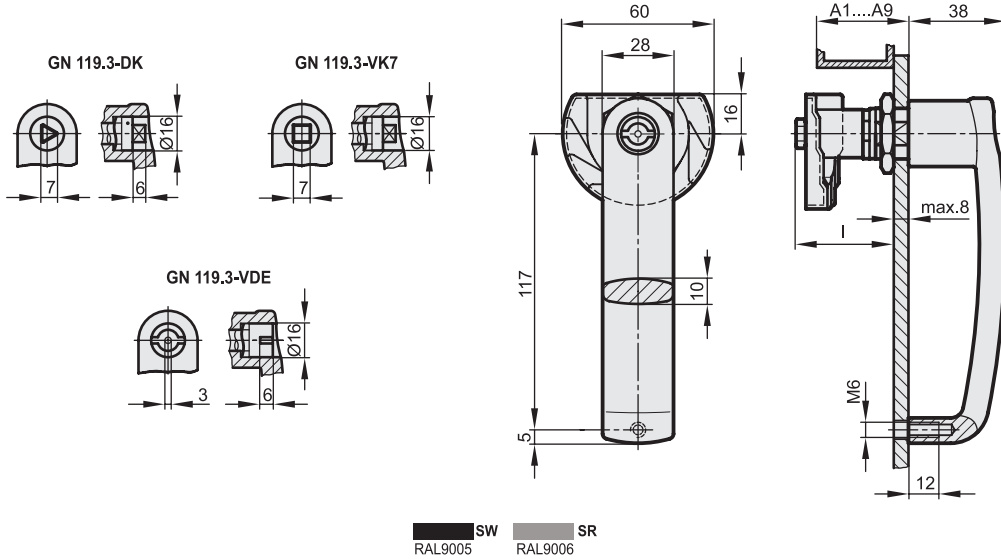

GN 119.3-DK

Code SR	Code SW	Description	A1...A9	l	⚖
GN.38611	GN.38612	GN 119.3-DK-A1-*	17 + 25	28	424
GN.38613	GN.38614	GN.119.3-DK-A2-*	22 + 30	33	431
GN.38615	GN.38616	GN.119.3-DK-A3-*	27 + 35	38	441
GN.38617	GN.38618	GN.119.3-DK-A4-*	32 + 40	43	453
GN.38619	GN.38620	GN.119.3-DK-A5-*	37 + 45	48	465
GN.38621	GN.38622	GN.119.3-DK-A6-*	42 + 50	53	473
GN.38623	GN.38624	GN.119.3-DK-A7-*	47 + 55	58	485
GN.38625	GN.38626	GN.119.3-DK-A8-*	52 + 60	63	495
GN.38627	GN.38628	GN.119.3-DK-A9-*	57 + 65	68	507

GN 119.3-VK7

Code SR	Code SW	Description	A1...A9	l	⚖
GN.38681	GN.38682	GN.119.3-VK7-A1-*	17 + 25	28	425
GN.38683	GN.38684	GN.119.3-VK7-A2-*	22 + 30	33	432
GN.38685	GN.38686	GN.119.3-VK7-A3-*	27 + 35	38	444
GN.38687	GN.38688	GN.119.3-VK7-A4-*	32 + 40	43	455
GN.38689	GN.38690	GN.119.3-VK7-A5-*	37 + 45	48	466
GN.38691	GN.38692	GN.119.3-VK7-A6-*	42 + 50	53	474
GN.38693	GN.38694	GN.119.3-VK7-A7-*	47 + 55	58	486
GN.38695	GN.38696	GN.119.3-VK7-A8-*	52 + 60	63	496
GN.38697	GN.38698	GN.119.3-VK7-A9-*	57 + 65	68	506

GN 119.3-VDE

Code SR	Code SW	Description	A1...A9	l	⚖
GN.38631	GN.38632	GN.119.3-VDE-A1-*	17 + 25	28	430
GN.38633	GN.38634	GN.119.3-VDE-A2-*	22 + 30	33	437
GN.38635	GN.38636	GN.119.3-VDE-A3-*	27 + 35	38	447
GN.38637	GN.38638	GN.119.3-VDE-A4-*	32 + 40	43	456
GN.38639	GN.38640	GN.119.3-VDE-A5-*	37 + 45	48	469
GN.38641	GN.38642	GN.119.3-VDE-A6-*	42 + 50	53	479
GN.38643	GN.38644	GN.119.3-VDE-A7-*	47 + 55	58	489
GN.38645	GN.38646	GN.119.3-VDE-A8-*	52 + 60	63	501
GN.38647	GN.38648	GN.119.3-VDE-A9-*	57 + 65	68	510

* Complete by adding the type of colour index of the handle: SW (black) or SR (grey).

