

PAT. PEND.

# S Couplers

## Energy saving by pressure loss reduction

**Cv factor** increased by **39%** (Thread R1/4 type Compared to the conventional model\*)

**Plug insertion force** reduced by **22% (20 N)** (Compared to the conventional model\* at 0.5 MPa)

**Lightweight** reduced by **14% (12 g)** (Compared to the conventional model\*)

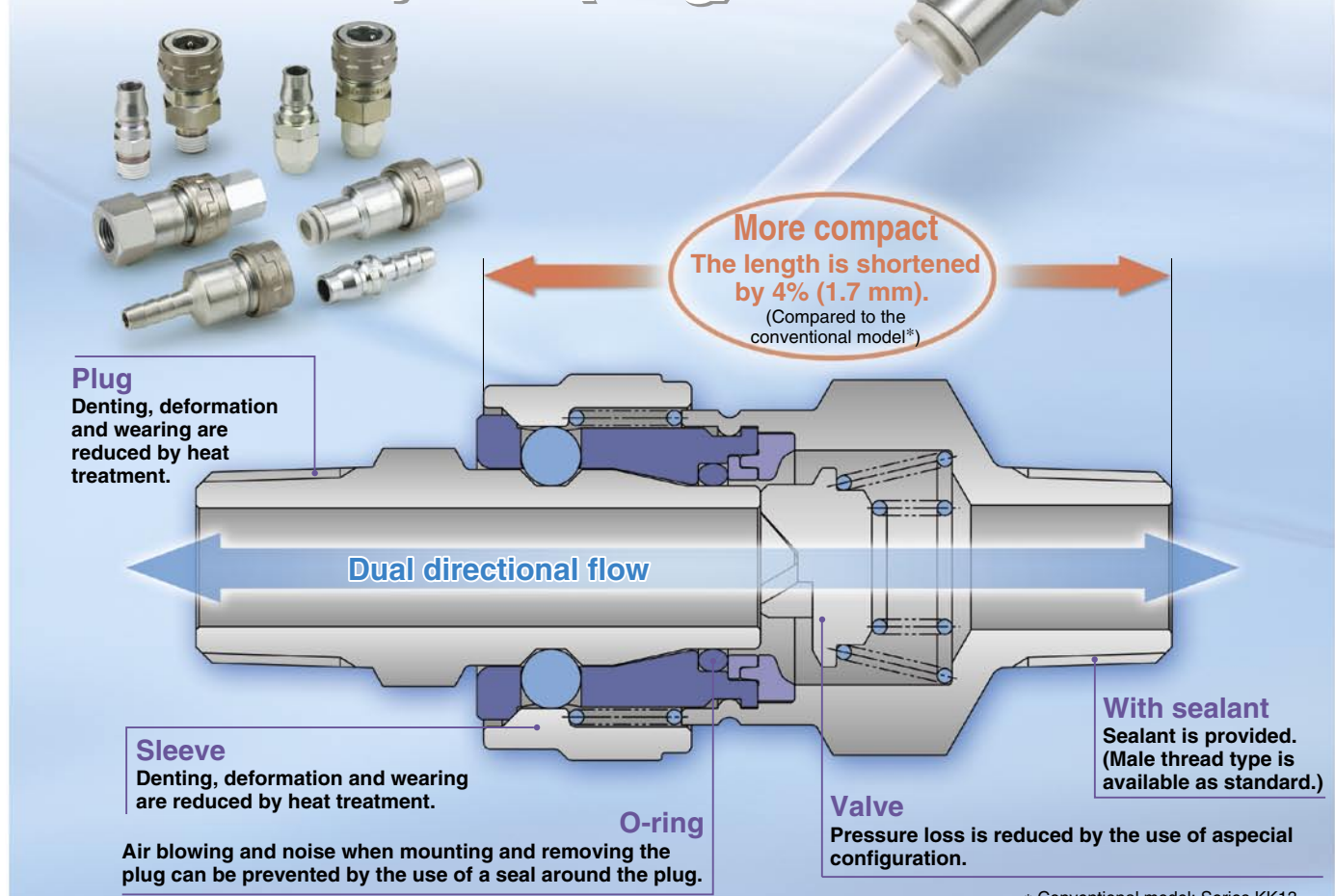

One-touch fitting provided type is standardised.



Metric size:  $\phi 6$ ,  $\phi 8$ ,  $\phi 10$ ,  $\phi 12$   
Inch size:  $\phi 1/4$ ",  $\phi 5/16$ ",  $\phi 3/8$ ",  $\phi 1/2$ "

With lock mechanism (Semi-standard)

Removal by unexpected impact can be prevented.  
Locked and released position can be maintained by the detent on the sleeve.  
Possible to remove and mount the coupler even if the locked mark is invisible.

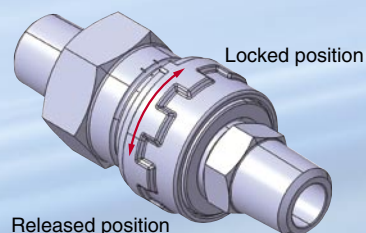

# Series KK130



CAT.EUS50-32A-UK

# Energy saving and cost reduction

Since pressure loss is smaller than the conventional product (Series KK13), even if inlet pressure is reduced, equivalent outlet pressure and flow rate can be achieved when it is used for air blow. It is possible to reduce the cost with lower air and energy consumption of compressors.

## Inlet pressure and compressor electric power cost against operating flow rate (per coupler)

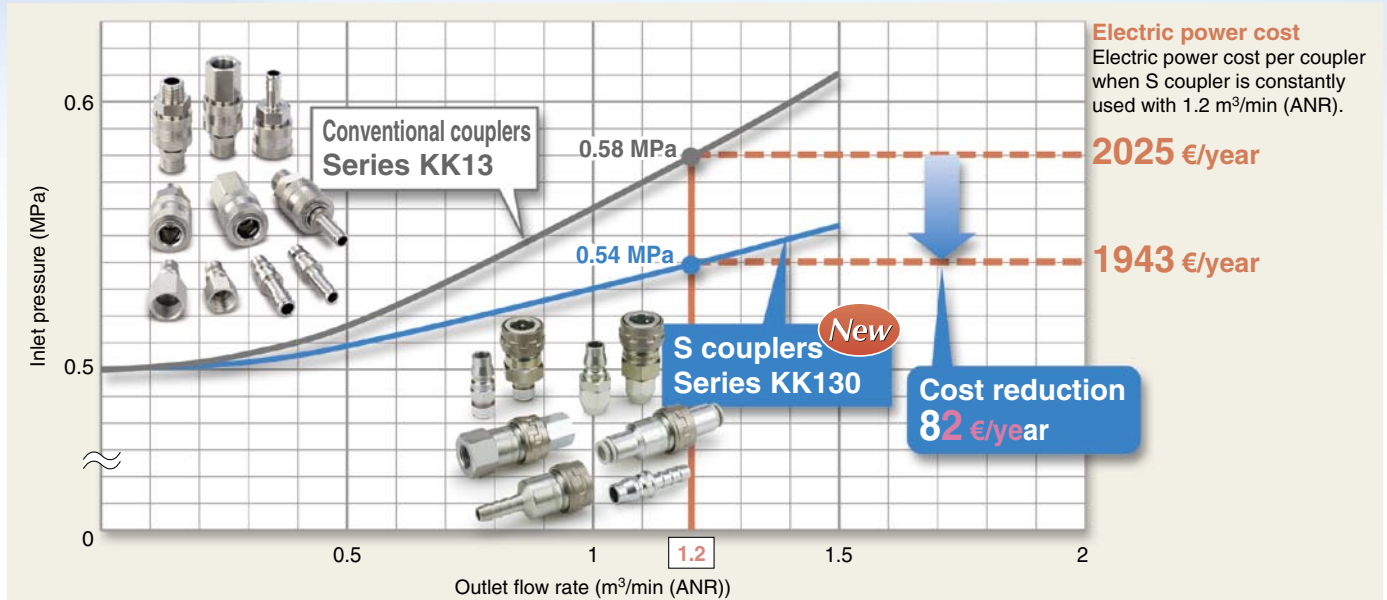

### [Calculation conditions]

Operating pressure at the outlet: 0.5 MPa  
Compressor efficiency: 0.7  
Electric power cost: 0,11 €/kWh  
Annual operating time: 2500 hours

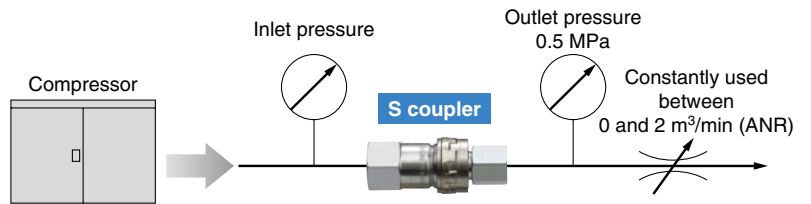

## Cost reduction effect by using S couplers in a factory

It is possible to achieve a large cost reduction when looking at the effect on a factory scale.



Quantity of S couplers used in a factory (pcs.)	500	1,000	1,500	2,000
Air consumption of whole factory (m <sup>3</sup> /hr (ANR))	3,600	7,200	10,800	14,400
Compressor capacity of whole factory (kWh)	650	1,300	1,950	2,600

Note) The relationship between the total compressor capacity, air consumption and quantity of S couplers is shown as a general guideline.

### [Calculation conditions]

50% of the total air consumed in the factory passes through the S coupler, and 4 S couplers are used at the end of the line.  
Operating pressure at the outlet: 0.5 MPa  
Air consumption of one line at end: 1.2 m<sup>3</sup>/min (ANR)  
Air consumption time: 20% of annual operating time of 2500 hours  
Compressor efficiency: 0.7  
Electric power cost: 0,11 €/kWh  
Compressor capacity: 8 m<sup>3</sup>/kWh

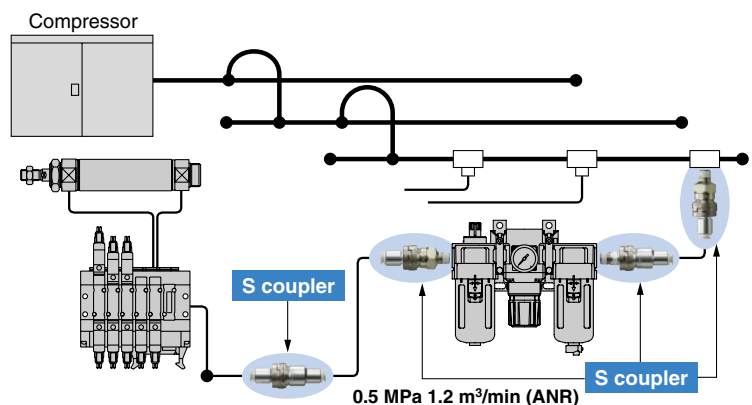

# Series KK130 Variations



## Plug (P)

### Male thread type

	Port size	Model
	R1/8	<b>KK130P-01MS</b>
	R1/4	<b>-02MS</b>
	R3/8	<b>-03MS</b>
	R1/2	<b>-04MS</b>
	NPT1/8	<b>-N01MS</b>
	NPT1/4	<b>-N02MS</b>
	NPT3/8	<b>-N03MS</b>
	NPT1/2	<b>-N04MS</b>

### Female thread type

	Port size	Model
	Rc1/8	<b>KK130P-01F</b>
	Rc1/4	<b>-02F</b>
	Rc3/8	<b>-03F</b>
	Rc1/2	<b>-04F</b>
	NPT1/8	<b>-N01F</b>
	NPT1/4	<b>-N02F</b>
	NPT3/8	<b>-N03F</b>
	NPT1/2	<b>-N04F</b>

### Barb fitting type (for rubber hose)

	Hose nominal	Model
	6 (1/4")	<b>KK130P-07B</b>
	8 (1/4")	<b>-09B</b>
	9 (3/8")	<b>-11B</b>
	12 (1/2")	<b>-13B</b>

\* The figures in ( ) indicate the internal diameter of the applicable hose.

### Nut fitting type (for fiber reinforced urethane hose)

	Applicable hose I.D./O.D.	Model
	5/8	<b>KK130P-50N</b>
	6/9	<b>-60N</b>
	6.5/10	<b>-65N</b>
	8/12	<b>-80N</b>
	8.5/12.5	<b>-85N</b>
11/16	<b>-110N</b>	

### One-touch fitting type

	Applicable tube O.D.		Model
	Metric size mm	6	<b>KK130P-06H</b>
		8	<b>-08H</b>
		10	<b>-10H</b>
		12	<b>-12H</b>
	Inch size	1/4"	<b>-07H</b>
		5/16"	<b>-09H</b>
		3/8"	<b>-11H</b>
		1/2"	<b>-13H</b>



## Socket (S)

### Male thread type

	Port size	Model*
	R1/8	<b>KK130S-01MS</b>
	R1/4	<b>-02MS</b>
	R3/8	<b>-03MS</b>
	R1/2	<b>-04MS</b>
	NPT1/8	<b>-N01MS</b>
	NPT1/4	<b>-N02MS</b>
	NPT3/8	<b>-N03MS</b>
	NPT1/2	<b>-N04MS</b>

\* Refer to the how to order on page 1 for the sleeve lock mechanism provided type.

### Female thread type

	Port size	Model*
	Rc1/8	<b>KK130S-01F</b>
	Rc1/4	<b>-02F</b>
	Rc3/8	<b>-03F</b>
	Rc1/2	<b>-04F</b>
	NPT1/8	<b>-N01F</b>
	NPT1/4	<b>-N02F</b>
	NPT3/8	<b>-N03F</b>
	NPT1/2	<b>-N04F</b>

\* Refer to the how to order on page 1 for the sleeve lock mechanism provided type.

### Barb fitting type (for rubber hose)

	Hose nominal	Model*
	6 (1/4")	<b>KK130S-07B</b>
	8 (1/4")	<b>-09B</b>
	9 (3/8")	<b>-11B</b>
	12 (1/2")	<b>-13B</b>

\* Refer to the how to order on page 1 for the sleeve lock mechanism provided type.  
\* The figures in ( ) indicate the internal diameter of the applicable hose.

### Nut fitting type (for fiber reinforced urethane hose)

	Applicable hose I.D./O.D.	Model*
	5/8	<b>KK130S-50N</b>
	6/9	<b>-60N</b>
	6.5/10	<b>-65N</b>
	8/12	<b>-80N</b>
	8.5/12.5	<b>-85N</b>
11/16	<b>-110N</b>	

\* Refer to the how to order on page 1 for the sleeve lock mechanism provided type.

### One-touch fitting type

	Applicable tube O.D.		Model*
	Metric size mm	6	<b>KK130S-06H</b>
		8	<b>-08H</b>
		10	<b>-10H</b>
		12	<b>-12H</b>
	Inch size	1/4"	<b>-07H</b>
		5/16"	<b>-09H</b>
		3/8"	<b>-11H</b>
		1/2"	<b>-13H</b>

\* Refer to the how to order on page 1 for the sleeve lock mechanism provided type.

# S Couplers

## Series *KK130*



### Specifications

Fluid	Air (Note)
Operating pressure range	0 to 1.5 MPa One-touch fitting type: 0 to 1.0 MPa
Proof pressure	2.0 MPa
Ambient and fluid temperature	-20 to 80°C (No freezing) One-touch fitting type: -5 to 60°C (No freezing)
Plating	Sleeve: Electroless nickel plated Other external metal parts: Zinc chromated
Sealant	Male thread with sealant

Note) Cannot be used for water.

### JIS Symbol

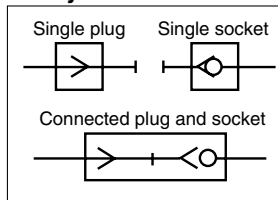

### Performance

Plug and socket connection	Sleeve slide detachable type
Check valve	Socket: Built-in check valve
Flow direction	Dual directional
Sleeve lock mechanism	Manual locking type (with detent) Semi-standard

### How to Order

**KK130 P - 02 MS**

130 series

Socket/Plug

Symbol	Type
<b>P</b>	Plug
<b>S</b>	Socket
<b>L</b>	Semi-standard Socket (With sleeve lock mechanism)

Connection type

Symbol	Type
<b>MS</b>	Male thread (With sealant)
<b>F</b>	Female thread
<b>B</b>	With barb fitting
<b>N</b>	With nut fitting
<b>H</b>	With one-touch fitting

Port size variations

Male/Female thread type

Symbol	Thread size
<b>01</b>	R, Rc1/8
<b>02</b>	R, Rc1/4
<b>03</b>	R, Rc3/8
<b>04</b>	R, Rc1/2
<b>N01</b>	NPT1/8
<b>N02</b>	NPT1/4
<b>N03</b>	NPT3/8
<b>N04</b>	NPT1/2

Barb fitting type

Symbol	Hose nominal
<b>07</b>	6 (1/4")
<b>09</b>	8 (1/4")
<b>11</b>	9 (3/8")
<b>13</b>	12 (1/2")

\* The figures in ( ) indicate the internal diameter of the applicable hose.

Nut fitting type

Symbol	Applicable hose I.D./O.D. mm
<b>50</b>	5/8
<b>60</b>	6/9
<b>65</b>	6.5/10
<b>80</b>	8/12
<b>85</b>	8.5/12.5
<b>110</b>	11/16

One-touch fitting type

Symbol	Applicable tube O.D. mm	
<b>06</b>	ø6	Metric size
<b>08</b>	ø8	
<b>10</b>	ø10	
<b>12</b>	ø12	
<b>07</b>	ø1/4"	Inch size
<b>09</b>	ø5/16"	
<b>11</b>	ø3/8"	
<b>13</b>	ø1/2"	

## Flow-rate Characteristics [Representative Value]

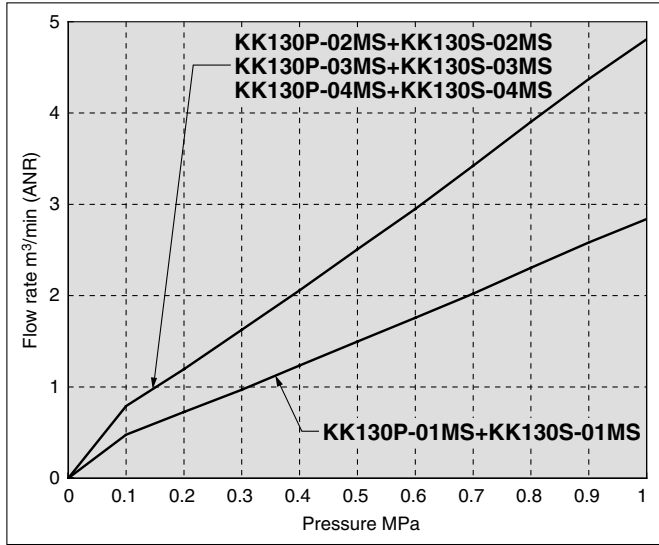

\* This flow-rate characteristic test method complies with JIS B 8390 (Pneumatic fluid power – Components using compressible fluids – Determination of flow-rate characteristics)  
 \* The figures are representative values when the same type of plug and socket are connected.

Connection type			Sonic conductance C [dm³/(s·bar)]	Critical pressure ratio b	Flow coefficient Cv	Effective area S [mm²]
Type	Symbol	Connection				
Male thread	-01MS	R1/8	4.2	0.4	1.2	21
	-02MS	R1/4	7.0	0.4	1.9	35
	-03MS	R3/8	7.0	0.5	2.1	35
	-04MS	R1/2	7.0	0.5	2.1	35
Female thread	-01F	Rc1/8	6.0	0.5	1.8	30
	-02F	Rc1/4	7.0	0.5	2.1	35
	-03F	Rc3/8	7.0	0.5	2.1	35
	-04F	Rc1/2	7.0	0.5	2.1	35
With barb fitting	-07B	6 (1/4")	2.0	0.4	0.5	10
	-09B	8 (1/4")	3.0	0.4	0.8	15
	-11B	10 (3/8")	6.0	0.5	1.8	30
	-13B	12 (1/2")	7.0	0.5	2.1	35
With nut fitting	-50N	5/8	2.0	0.4	0.5	10
	-60N	6/9	3.5	0.4	1.0	18
	-65N	6.5/10	4.2	0.4	1.2	21
	-80N	8/12	7.0	0.4	1.9	35
	-85N	8.5/12.5	7.0	0.4	1.9	35
	-110N	11/16	7.0	0.5	2.1	35
With one-touch fitting	-06H	ø6	2.0	0.4	0.5	10
	-08H	ø8	4.4	0.5	1.3	22
	-10H	ø10	7.0	0.5	1.8	35
	-12H	ø12	7.0	0.5	2.1	35

## Construction

<With one-touch fitting>

<With one-touch fitting>

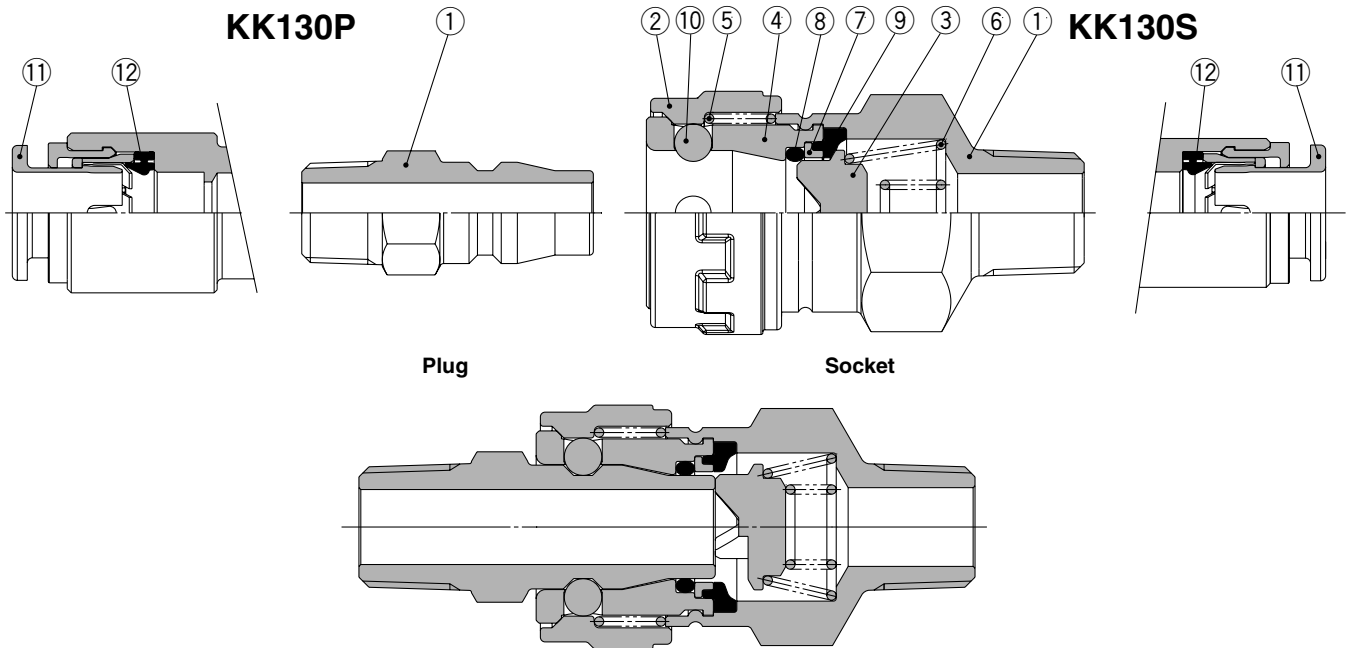

Figure: Connected plug and socket

### Plug

No.	Description	Material	Note
1	Plug	Structural steel	Zinc chromated
11	Cassette	—	
12	Seal	NBR	

### Socket

No.	Description	Material	Note
1	Socket body	Structural steel	Zinc chromated
2	Sleeve	Steel wire	Electroless nickel plated
3	Valve	Steel wire	Zinc chromated
4	Main body	Steel wire	Zinc chromated
5	Sleeve spring	Stainless steel	
6	Valve spring	Stainless steel	
7	Holder	Steel band	Zinc chromated
8	Plug O-ring	NBR	
9	Seal	NBR	
10	Steel ball	SUJ	
11	Cassette	—	
12	Seal	NBR	

# Series KK130

## Dimensions

### Plug (KK130P)

### Socket (KK130S, L)

#### Male thread type

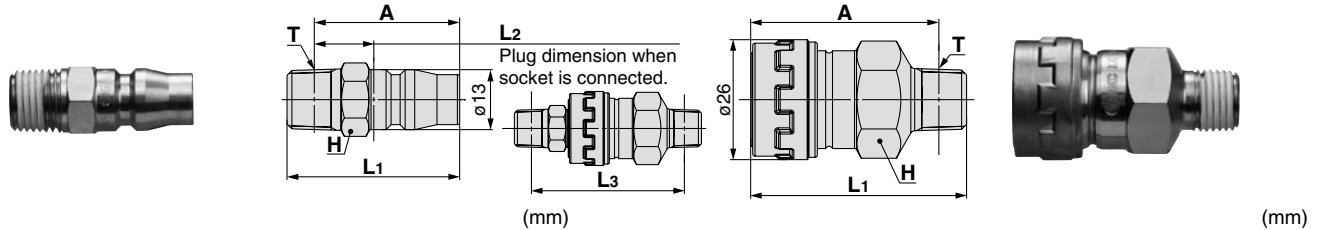

Model	T Connection male thread	H Width across flats	L1	L2	A <sup>*1</sup>	Min. hole size	Weight g	When connected Full length L3
<b>KK130P-01MS</b>	R1/8	14	34.0	11.1	30.0	6.0	18	51.1
<b>-02MS</b>	R1/4	14	38.0	13.1	32.0	8.0	22	53.9
<b>-03MS</b>	R3/8	19	39.0	13.6	32.5	8.0	37	53.3
<b>-04MS</b>	R1/2	22	43.0	16.1	35.0	8.0	52	55.9
<b>KK130P-N01MS</b>	NPT1/8	14	34.0	10.1	29.0	6.0	18	49.4
<b>-N02MS</b>	NPT1/4	14	38.0	11.6	30.5	8.0	22	51.5
<b>-N03MS</b>	NPT3/8	19	39.0	12.6	31.5	8.0	37	51.7
<b>-N04MS</b>	NPT1/2	22	43.0	14.1	33.0	8.0	52	52.3

\*1 Reference dimension after installation

\*1 Reference dimension after installation

#### Female thread type

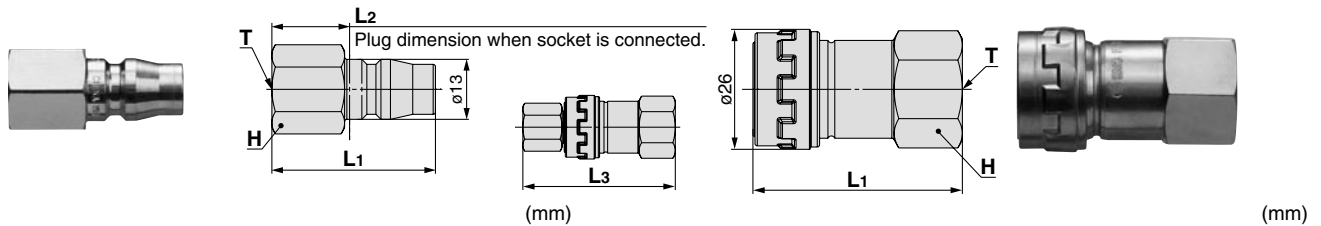

Model	T Connection male thread	H Width across flats	L1	L2	Min. hole size	Weight g	When connected Full length L3
<b>KK130P-01F</b>	Rc1/8	14	30.0	11.1	8.0	18	53.0
<b>-02F</b>	Rc1/4	17	36.0	17.1	8.0	28	62.5
<b>-03F</b>	Rc3/8	21	37.0	18.1	8.0	38	66.5
<b>-04F</b>	Rc1/2	27	42.0	23.1	8.0	73	76.0
<b>KK130P-N01F</b>	NPT1/8	14	30.0	11.1	8.0	18	53.0
<b>-N02F</b>	NPT1/4	17	36.0	17.1	8.0	28	62.5
<b>-N03F</b>	NPT3/8	21	37.0	18.1	8.0	38	66.5
<b>-N04F</b>	NPT1/2	27	42.0	23.1	8.0	73	76.0

#### Barb fitting type (for rubber hose)

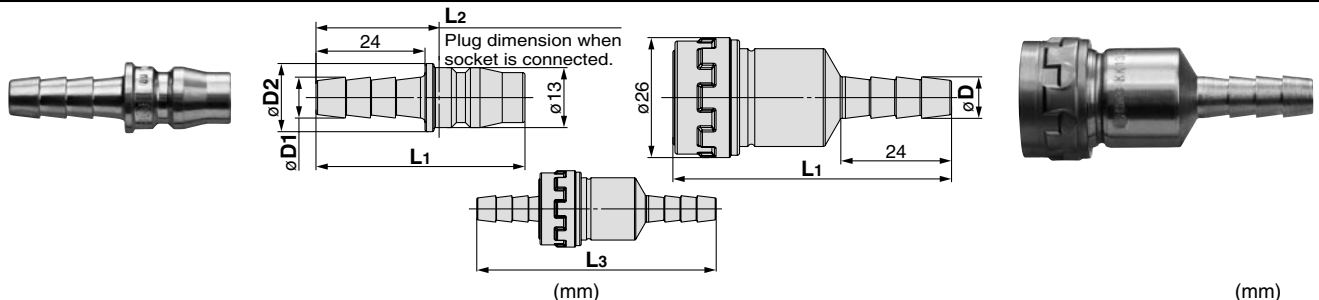

Model	Hose nominal	øD1	øD2	L1	L2	Min. hole size	Weight g	When connected Full length L3
<b>KK130P-07B</b>	6 (1/4")	7.2	14.0	46.0	27.1	4.5	16	88.0
<b>-09B</b>	8 (1/4")	9.0	15.0	46.0	27.1	5.0	19	87.5
<b>-11B</b>	9 (3/8")	11.3	16.0	46.0	27.1	8.0	19	87.0
<b>-13B</b>	12 (1/2")	15.0	18.0	46.0	27.1	8.0	33	86.0

\* The figures in ( ) indicate the internal diameter of the applicable hose.

\* The figures in ( ) indicate the internal diameter of the applicable hose.

## Plug (KK130P)

## Socket (KK130S, L)

### Nut fitting type (for fiber reinforced urethane hose)

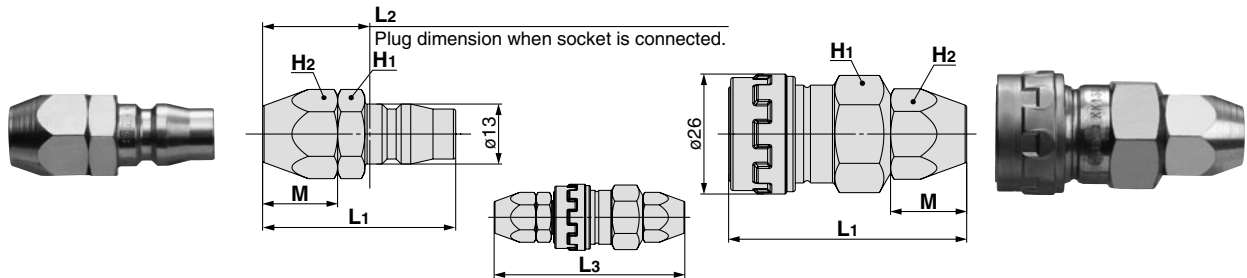

Model	Applicable hose I.D./O.D.	H1	H2	L1	L2	M	Min. hole size	Weight g	When connected Full length L3	Model	Applicable hose I.D./O.D.	H1	H2	L1	M	Min. hole size	Weight g
<b>KK130P-50N</b>	5/8	14	14	39.7	20.8	13.7	4.5	27	70.4	<b>KK130S(L)-50N</b>	5/8	22	14	49.6	13.7	4.5	85
<b>-60N</b>	6/9	17	17	42.4	23.5	16.4	5.5	42	75.1	<b>-60N</b>	6/9	22	17	51.6	16.4	5.5	95
<b>-65N</b>	6.5/10	17	17	42.5	23.6	16.5	6.0	39	75.2	<b>-65N</b>	6.5/10	22	17	51.6	16.5	6.0	92
<b>-80N</b>	8/12	19	19	43.4	24.5	17.4	8.0	46	77.1	<b>-80N</b>	8/12	22	19	52.6	17.4	8.0	97
<b>-85N</b>	8.5/12.5	19	19	43.4	24.5	17.4	8.0	48	77.1	<b>-85N</b>	8.5/12.5	22	19	52.6	17.4	8.0	101
<b>-110N</b>	11/16	24	24	49.1	30.2	20.1	8.0	86	82.8	<b>-110N</b>	11/16	24	24	52.6	20.1	10.0	119

### One-touch fitting type

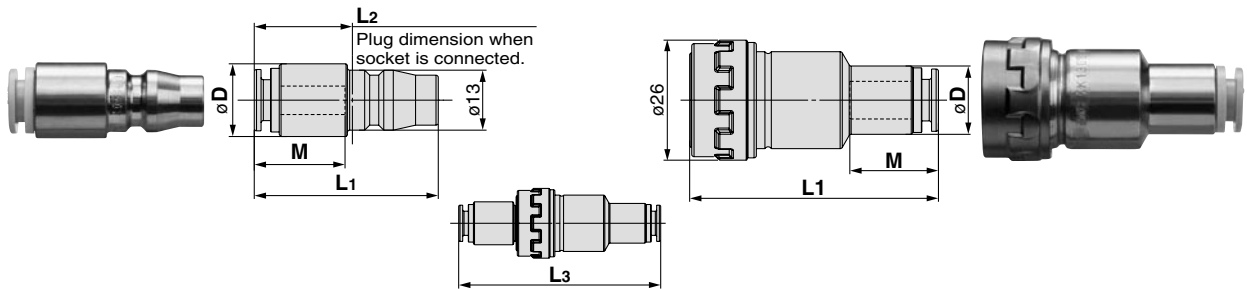

Model	Applicable tube O.D. mm	D	L1	L2	M	Min. hole size	Weight g	When connected Full length L3	Model	Applicable tube O.D. mm	D	L1	M	Min. hole size	Weight g
<b>KK130P-06H</b>	6	15.0	39.9	21.0	16.7	4.5	24	73.3	<b>KK130S(L)-06H</b>	6	13.0	52.3	16.7	4.5	72
<b>-08H</b>	8	16.0	39.9	21.0	18.6	6.0	24	74.3	<b>-08H</b>	8	14.8	53.3	18.6	6.0	74
<b>-10H</b>	10	18.0	40.4	21.5	20.7	8.0	24	76.8	<b>-10H</b>	10	17.8	55.3	20.7	9.0	77
<b>-12H</b>	12	20.0	42.7	23.8	21.7	8.0	29	79.1	<b>-12H</b>	12	20.0	55.3	21.7	9.0	80
<b>-07H</b>	1/4"	15.0	39.9	21.0	16.7	4.5	24	73.3	<b>-07H</b>	1/4"	13.0	52.3	16.7	4.5	72
<b>-09H</b>	5/16"	16.0	39.9	21.0	18.6	6.0	24	74.3	<b>-09H</b>	5/16"	14.8	53.3	18.6	6.0	74
<b>-11H</b>	3/8"	18.0	40.4	21.5	20.7	7.0	25	76.8	<b>-11H</b>	3/8"	17.6	55.3	20.7	7.0	79
<b>-13H</b>	1/2"	20.0	42.7	23.8	21.7	8.0	27	79.1	<b>-13H</b>	1/2"	20.0	55.3	21.7	9.0	78

# Series KK130

## How to Operate

### Mounting

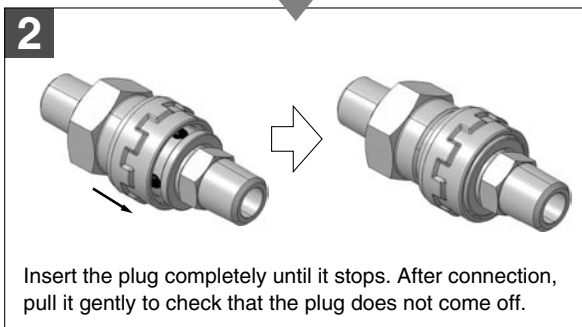
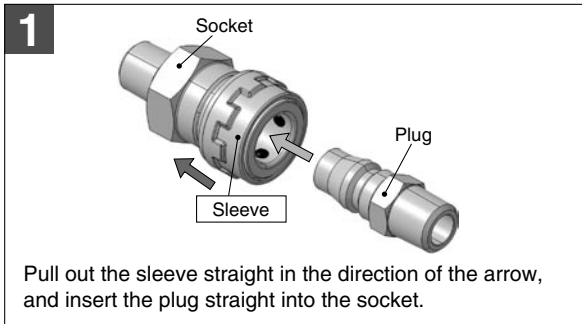

### Releasing

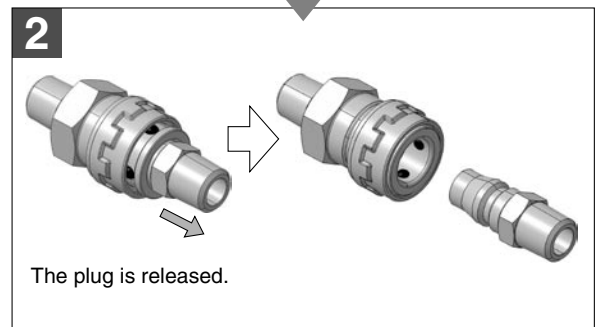
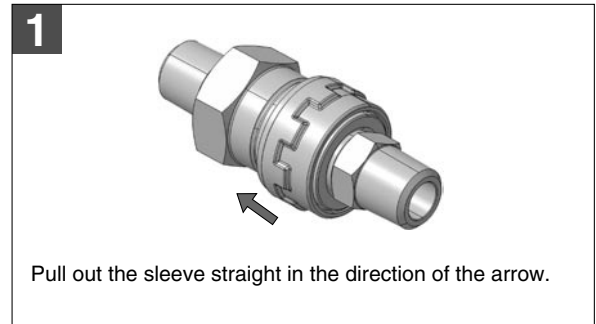

### With sleeve lock mechanism (Semi-standard)

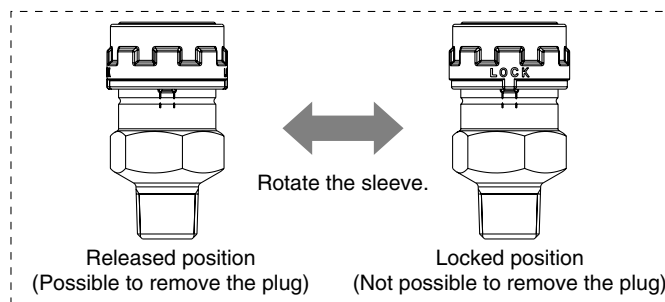

Note) Do not apply pressure when rotating the sleeve. If it is pressurised, the detent of the locked and released position may become unclear due to the pressure.

### Mounting

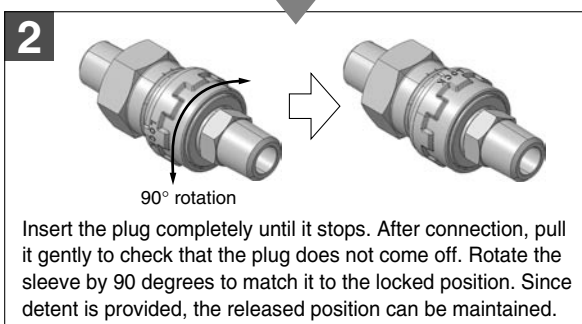
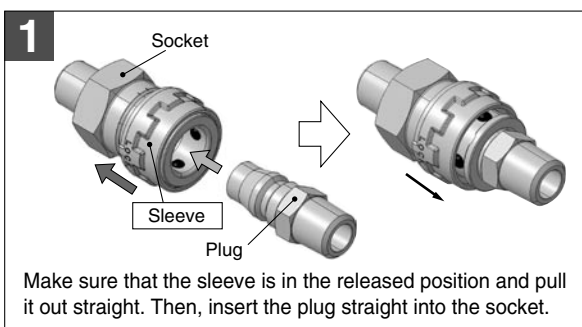

### Releasing

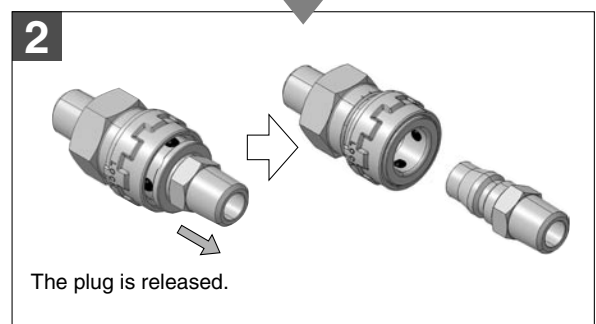
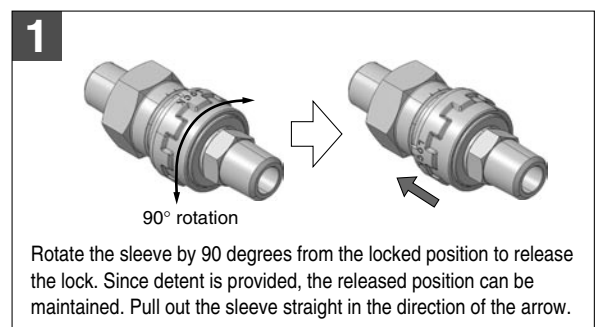







# Safety Instructions

These safety instructions are intended to prevent hazardous situations and/or equipment damage. These instructions indicate the level of potential hazard with the labels of “**Caution,**” “**Warning**” or “**Danger.**” They are all important notes for safety and must be followed in addition to International Standards (ISO/IEC)<sup>Note 1)</sup>, and other safety regulations.

Note 1) ISO 4414: Pneumatic fluid power – General rules relating to systems.  
ISO 4413: Hydraulic fluid power – General rules relating to systems.  
IEC 60204-1: Safety of machinery – Electrical equipment of machines. (Part 1: General requirements)  
ISO 10218: Manipulating industrial robots - Safety.  
etc.

-  **Caution:** **Caution** indicates a hazard with a low level of risk which, if not avoided, could result in minor or moderate injury.
-  **Warning:** **Warning** indicates a hazard with a medium level of risk which, if not avoided, could result in death or serious injury.
-  **Danger :** **Danger** indicates a hazard with a high level of risk which, if not avoided, will result in death or serious injury.

## Warning

### 1. The compatibility of the product is the responsibility of the person who designs the equipment or decides its specifications.

Since the product specified here is used under various operating conditions, its compatibility with specific equipment must be decided by the person who designs the equipment or decides its specifications based on necessary analysis and test results. The expected performance and safety assurance of the equipment will be the responsibility of the person who has determined its compatibility with the product. This person should also continuously review all specifications of the product referring to its latest catalogue information, with a view to giving due consideration to any possibility of equipment failure when configuring the equipment.

### 2. Only personnel with appropriate training should operate machinery and equipment.

The product specified here may become unsafe if handled incorrectly. The assembly, operation and maintenance of machines or equipment including our products must be performed by an operator who is appropriately trained and experienced.

### 3. Do not service or attempt to remove product and machinery/equipment until safety is confirmed.

1. The inspection and maintenance of machinery/equipment should only be performed after measures to prevent falling or runaway of the driven objects have been confirmed.
2. When the product is to be removed, confirm that the safety measures as mentioned above are implemented and the power from any appropriate source is cut, and read and understand the specific product precautions of all relevant products carefully.
3. Before machinery/equipment is restarted, take measures to prevent unexpected operation and malfunction.

### 4. Contact SMC beforehand and take special consideration of safety measures if the product is to be used in any of the following conditions.

1. Conditions and environments outside of the given specifications, or use outdoors or in a place exposed to direct sunlight.
2. Installation on equipment in conjunction with atomic energy, railways, air navigation, space, shipping, vehicles, military, medical treatment, combustion and recreation, or equipment in contact with food and beverages, emergency stop circuits, clutch and brake circuits in press applications, safety equipment or other applications unsuitable for the standard specifications described in the product catalogue.
3. An application which could have negative effects on people, property, or animals requiring special safety analysis.
4. Use in an interlock circuit, which requires the provision of double interlock for possible failure by using a mechanical protective function, and periodical checks to confirm proper operation.



# Safety Instructions

## Caution

### 1. The product is provided for use in manufacturing industries.

The product herein described is basically provided for peaceful use in manufacturing industries.

If considering using the product in other industries, consult SMC beforehand and exchange specifications or a contract if necessary.

If anything is unclear, contact your nearest sales branch.

## Limited warranty and Disclaimer/Compliance Requirements

The product used is subject to the following “Limited warranty and Disclaimer” and “Compliance Requirements”. Read and accept them before using the product.

### Limited warranty and Disclaimer

1. The warranty period of the product is 1 year in service or 1.5 years after the product is delivered.<sup>Note 2)</sup>  
Also, the product may have specified durability, running distance or replacement parts. Please consult your nearest sales branch.
2. For any failure or damage reported within the warranty period which is clearly our responsibility, a replacement product or necessary parts will be provided.  
This limited warranty applies only to our product independently, and not to any other damage incurred due to the failure of the product.
3. Prior to using SMC products, please read and understand the warranty terms and disclaimers noted in the specified catalogue for the particular products.

#### **Note 2) Vacuum pads are excluded from this 1 year warranty.**

A vacuum pad is a consumable part, so it is warranted for a year after it is delivered.

Also, even within the warranty period, the wear of a product due to the use of the vacuum pad or failure due to the deterioration of rubber material are not covered by the limited warranty.

### Compliance Requirements

1. The use of SMC products with production equipment for the manufacture of weapons of mass destruction (WMD) or any other weapon is strictly prohibited.
2. The exports of SMC products or technology from one country to another are governed by the relevant security laws and regulations of the countries involved in the transaction. Prior to the shipment of a SMC product to another country, assure that all local rules governing that export are known and followed.



# Series KK130

## Specific Product Precautions 1

Be sure to read before handling.

Refer to back pages 1 and 2 for Safety Instructions, "Handling Precautions for SMC Products" (M-E03-3) for Fittings and Tubing Precautions.

### Selection

#### Warning

##### 1. Make sure to confirm the specifications.

Do not use with pressures or temperatures outside the range of specifications, as this may result in damage and malfunction. (Refer to the specifications on page 1.) SMC takes no responsibility for damage incurred by use in excess of the specification range.

##### 2. Prohibition of disassembly and modification

Do not disassemble or modify (including additional machining) the main body. False use may cause an injury or accident.

##### 3. Confirm that PTFE can be used in application.

Thread sealant contains PTFE (polytetrafluoroethylene) powder. Confirm if the use of it may cause any adverse effect on the system.

##### 4. Cannot be used as a stop valve that requires zero leakage.

A certain amount of leakage is allowed during operation.

##### 5. Refer to the table below for whether the S coupler can be connected.

Series	KK	KKH	KKA	KKG	KK13	KK130
KK13	—	—	—	—	○	○
KK130	—	—	—	—	○	○

When the KK130 series is connected to other companies' products, confirm manufacturers and other information before using it.

#### Caution

##### 1. When connecting the plug to the socket, select the series suitable for the connection.

If the series are not matched, they cannot be connected. Mismatches will cause leakage, damage, and disconnection of the plug. Inserting a plug other than the specialised plug into the socket may result in equipment damage.

##### 2. Do not rotate or turn the S coupler and piping to which it is connected.

The connection of the piping might be damaged or come undone.

##### 3. Do not use couplers with flammable, explosive, or toxic substances, such as gas, gas fuel, and refrigerant.

They may leak from the S coupler or from inside the tubing to the outside.

##### 4. Operate with a surge pressure of no more than the maximum operating pressure.

If the surge pressure exceeds the maximum operating pressure, it will cause damage to couplers and tubing.

##### 5. Do not use the S coupler with water or steam.

Corrosion of the metal material and deterioration of the sealing material may result from long-term use with water or steam.

##### 6. The tube bending radius in the vicinity of the fitting should be at least the minimum bending radius of the tube.

If the bending radius is less than the minimum value, fittings may damage, or tube may crack or be crushed. The minimum bending radius, with the exception of TU polyurethane tube, TUH hard polyurethane tube, TUS soft polyurethane tube, TRBU FR double layer polyurethane tube, TH FEP tube, TL PFA tube, TD modified PTFE tube, is measured as following in accordance with JIS B 8381-1995.

Tube deformation ratio at the minimum bending radius is obtained through the following formula, based on tube diameter and mandrel diameter by wrapping the same radius mandrel tube.

$$\eta = \left(1 - \frac{L-D}{2d}\right) \times 100$$

Tube deformation ratio at the minimum bending radius

Mandrel

Here,  $\eta$ : Deformation ratio (%)  
d: Tube O.D. (mm)  
L: Measured length (mm)  
D: Mandrel diameter (mm)  
(Twice against the minimum bending radius)

Test temperature: 20 ±5°C  
Relative humidity: 65 ±5%

##### 7. Applicable for air.

Consult with SMC if using other fluids.

### Mounting

#### Warning

##### 1. Instruction manual

Mount and operate the product after reading the instruction manual carefully and understanding its contents. Also, keep the manual where it can be referred to as necessary.

##### 2. Ensure sufficient space for maintenance.

Be sure to allow the space required for maintenance and inspection.

##### 3. Tightening torque

When installing the products, tighten the screw with the recommended tightening torque.

##### 4. During use, pipe deterioration or damage to S couplers can result in disconnection of the piping and uncontrollable behavior of the piping.

To stop the piping from going out of control, use a protective cover or fix the piping in place.

##### 5. Do not use couplers where rotation normally occurs.

The couplers may be damaged.

##### 6. Avoid applications in which vibration or shock is directly applied to the fittings.

When mounting the S coupler to a piece of equipment that generates impact or vibration, do not connect the S coupler to the equipment directly. In that case, connect a hose whose length is 300 mm or more between the S couplers.



## Series KK130

# Specific Product Precautions 2

Be sure to read before handling.

Refer to back pages 1 and 2 for Safety Instructions, "Handling Precautions for SMC Products" (M-E03-3) for Fittings and Tubing Precautions.

### Mounting

#### ⚠ Warning

- S couplers with sleeve lock mechanism must be locked during operation in order to prevent sudden disconnection.**
- Install a stop valve at the supply pressure side of the socket.**  
Emergency shutdown may not be possible without it.

#### ⚠ Caution

- Preparation before piping**  
Before piping is connected, it should be thoroughly blown out by air (flushed) or washed to eliminate cutting chips, cutting oil, and other debris from inside the pipe.
- Before mounting, confirm the model and size, etc.**  
Also, confirm that there are no blemishes, nicks or cracks in the product.
- When connecting a pipe, consider factors such as changes in the piping length due to pressure, and allow sufficient leeway.**
- Mount so that S couplers and piping are not subjected to twisting, pulling or moment loads.**  
This can cause damage to S couplers and flattening, bursting or disconnection of piping, etc.
- Mount so that piping is not damaged due to tangling and abrasion.**  
This can cause flattening, bursting or disconnection of piping, etc.
- When screwing in the pipes or fittings, make sure to prevent cutting chips or the sealing material on the threaded portion of the pipe from entering the piping.**  
Also, if pipe tape is used, leave about 1 thread ridge exposed at the end of the threads.

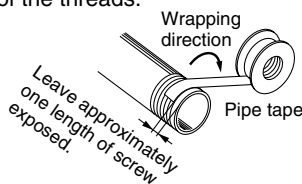

### Air Supply

#### ⚠ Warning

- Excessive drainage**  
Compressed air containing large amounts of drainage can cause malfunction of pneumatic equipment. As a countermeasure, install an air dryer or water separator before the filter.
- Drain flushing**  
If the drain removal from air filter is missed, drain will be flown out to the outlet side and may result in malfunction of pneumatic equipment. When removing drain is difficult, use of a filter with an auto drain is recommended.  
Refer to SMC's "Air Preparation Equipment" catalogue for further details on compressed air quality.
- Use clean air.**  
If the compressed air includes chemicals, synthetic oils containing organic solvents, salt or corrosive gases, etc., it can cause damage or malfunction in the system.

### Air Supply

#### ⚠ Caution

- Install an air filter.**  
Install an air filter upstream, near the valve. Select an air filter with a filtration degree of 5 µm or finer.
- As a countermeasure, install an aftercooler, air dryer or water separator.**  
Compressed air containing large amounts of drainage can cause malfunction of pneumatic equipment. As a countermeasure, install an aftercooler, air dryer or water separator.
- Ensure that the fluid and ambient temperature are within the specified range.**  
If the fluid temperature is 5°C or below, the moisture in the circuit could freeze, causing damage to the seals and leading to equipment malfunction. Therefore, take appropriate measures to prevent freezing.  
Refer to SMC's "Air Preparation Equipment" catalogue for further details on compressed air quality.

### Operating Environment

#### ⚠ Warning

- Do not use in atmospheres of corrosive gases, chemicals, sea water, water, water steam, or where there is direct contact with any of these.**
- Do not use in direct sunlight.**
- In locations near heat sources, protect against radiated heat.**
- Do not use in locations where static electric charges will be a problem.**  
This may cause system failure. Consult with SMC regarding use in this kind of environment.
- Do not use in locations where spatter occurs.**  
There is a danger of spatter causing a fire. Consult with SMC regarding use in this kind of environment.
- Do not use in environments where there is direct contact with liquids such as cutting oil, lubricating oil, coolant oil, or paints, etc.**  
This may cause connection and release failure and/or leakage. Consult with SMC regarding use in this kind of environment.
- Do not use in locations influenced by vibrations or impacts.**  
This may cause air leakage and S couplers damage. Consult with SMC regarding use in this kind of environment.
- Do not use in an environment where foreign matter such as spatter, metal powder or sand splashes onto or enters the product.**  
This may cause connection and release failure and/or leakage.
- Do not use in an environment where the product is constantly exposed to water.**  
Rust may occur.
- When the socket and plug are stored or not in use, make sure dust does not get stuck to them.**  
This may cause connection and release failure and/or leakage.



## Series KK130

# Specific Product Precautions 3

Be sure to read before handling.

Refer to back pages 1 and 2 for Safety Instructions, “Handling Precautions for SMC Products” (M-E03-3) for Fittings and Tubing Precautions.

### Operating Environment

#### Warning

11. **Do not use in places or environments where foreign matter sticks to the product or gets inside the product.**

It may cause air leakage or tube release.

### Maintenance

#### Caution

##### 1. Maintenance work

If handled improperly, compressed air can be dangerous. Assembly, handling, repair and element replacement of pneumatic systems should be performed by qualified personnel only.

##### 2. Drain flushing

Remove drainage from air filters regularly.

##### 3. Removal of equipment, and supply/exhaust of compressed air

When components are removed, first confirm that measures are in place to prevent workpieces from dropping, run-away equipment, etc. Then, cut the supply pressure and power, and exhaust all compressed air from the system using the residual pressure release function.

When machinery is restarted, proceed with caution after confirming that appropriate measures are in place to prevent cylinders from sudden movement.

##### 4. Be absolutely sure to wear safety glasses when conducting periodic inspections.

##### 5. Check for the following during regular maintenance, and replace components as necessary.

- a) Scratches, gouges, abrasion, corrosion, rust
- b) Leakage
- c) Twisting, flattening or distortion of tubes and hoses
- d) Hardening, deterioration or softening

##### 6. Do not repair or patch the replaced tubing, hoses or couplers for reuse.

Do not disassemble the S coupler.

### Handling

#### Warning

##### 1. When connecting the plug, hold the plug securely.

The plug may be uncoupled due to reaction at the time of connection.

##### 2. When connecting the plug, pull out the sleeve straight and insert the plug completely until it stops.

After the connection, gently pull the plug to see whether it will release. If not securely inserted, the plug may pop out due to the pressure.

##### 3. When connecting the plug, insert it straight into the socket.

If not inserted straight, the socket and/or plug may be damaged or cause a disconnection.

##### 4. When releasing the plug, hold it securely.

When releasing the plug, hold it securely. The connection pipe may go out of control due to reacting stress and/or residual pressure on the plug side.

##### 5. Do not press the inside of the socket with an incompatible plug and/or with a tool.

The internal fluid may be ejected and cause a dangerous situation. Also, the ejecting internal fluid may cause the sealings to come apart resulting in the product not functioning.

##### 6. Do not connect and remove the coupler when it is pressurised and residual pressure exists.

The coupler may fly out.

##### 7. Do not apply lateral load vertically to the connection direction of the plug or socket.

This may cause leakage and damage the coupler.

##### 8. Never pressurise when the plug is removed.

This may cause the connection piping to flap and be dangerous.

##### 9. When removing the plug, fluid in the piping leaks out.

Handle the fluid carefully, especially when using dangerous fluids such as a fluid with high temperature and pressure. The use of a stop valve is recommended.

##### 10. When using a fluid with high temperature, the S coupler will be heated, too.

Do not touch the coupler to prevent burning.

##### 11. When sleeve lock mechanism is provided, do not apply pressure when rotating the sleeve.

If it is pressurised, the detent of the locked and released position may become unclear due to the pressure.

##### 12. Do not disassemble the S coupler.



# Series KK130

## Specific Product Precautions 4

Be sure to read before handling.

Refer to back pages 1 and 2 for Safety Instructions, "Handling Precautions for SMC Products" (M-E03-3) for Fittings and Tubing Precautions.

### Plug Insertion Force in Pressurised Condition

Insertion Force of Series KK130

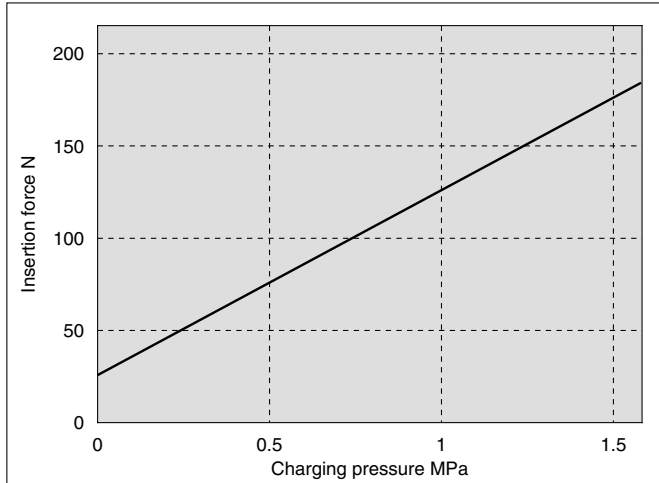

### Handling of Barb Fittings and Nut Fittings

#### ⚠ Caution

- 1. Prepare a hose band separately when using a barb fitting.**  
If the hose band is not used, the hose may come off.
- 2. When using a nut fitting, insert the hose all the way to the end and securely tighten it with the nut.**  
When the insertion of the hose or the tightening of the nut are not sufficient, the hose may come off.
- 3. Disconnection may occur depending on the material or the O.D. accuracy of the hose; therefore be sure to confirm the applicability of the hose.**

### Handling of Thread Type

#### ⚠ Caution

- 1. Screw the fitting into the hexagonal face of the S coupler, applying the appropriate wrench as close to the thread as possible.**

Place the wrench as close as possible to the thread. Do not apply pliers and pipe wrench to any other part other than the wrench flats. This may cause breakage or leakage.

- 2. Tightening torque**

Tighten fittings with sealant using the proper tightening torques in the table below. As a rule, they should be tightened 2 to 3 turns with a tool after first tightening by hand.

Connection thread size	Proper tightening torque N·m
NPT, R, Rc1/8	7 to 9
NPT, R, Rc1/4	12 to 14
NPT, R, Rc3/8	22 to 24
NPT, R, Rc1/2	28 to 30

- 3. When a fitting is over tightened, more of the sealant material is squeezed out.**

Remove the squeezed out sealant material.

- 4. When tightening is not sufficient, it will cause sealing failure or a loose fitting.**

- 5. Re-using**

- 1) Normally, a fitting with sealant can be re-used 2 to 3 times.
- 2) Remove the sealant material that is separated and adhering to a removed fitting with air blow, etc. If the separated sealant enters into nearby equipment, it will cause air leakage or malfunction.
- 3) When the sealant is no longer effective, wrap pipe tape over the sealant material and re-use the fitting. Do not use a sealant material other than pipe tape.

- 6. In cases where positioning is required, turning the fitting in the reverse direction after tightening will cause air leakage.**



# Series KK130

## Specific Product Precautions 5

Be sure to read before handling.

Refer to back pages 1 and 2 for Safety Instructions, "Handling Precautions for SMC Products" (M-E03-3) for Fittings and Tubing Precautions.

### Handling of One-touch Fittings

#### ⚠ Caution

1. Do not use in locations where static electric charges will be a problem.

This may cause system failure. Consult with SMC regarding use in this kind of environment.

2. Do not use in locations where spatter occurs.

There is a danger of spatter causing a fire. Consult with SMC regarding use in this kind of environment.

3. Tube attachment/detachment for one-touch fittings

##### 1) Attaching of tubing

(1) Take a tube having no flaws on its periphery and cut it off at a right angle. When cutting the tube, use tube cutters TK-1, 2 or 3. Do not use pinchers, nippers or scissors, etc. If cutting is done with tools other than tube cutters, the tube may become flattened, etc. This can make a secure installation impossible, and cause problems such as the tube pulling out after installation or air leakage.

(2) Polyurethane tube O.D. is swelled by applying internal pressure. As such, it may be that the tube cannot be re-inserted into a one-touch fitting. Make sure to confirm the tube O.D., and when the O.D. accuracy is more than +0.07 mm for  $\phi 2$  and +0.15 mm for other sizes, insert into a one-touch fitting again without cutting the tube to use it. When the tube is re-inserted into a one-touch fitting, make sure to confirm that the tube is able to go through the release button smoothly.

(3) Grasp the tube and push it in slowly, inserting it securely all the way into the fitting.

(4) After inserting the tube, pull on it lightly to confirm that it will not come out. If it is not installed securely all the way into the fitting, this can cause problems such as air leakage or the tube pulling out.

##### 2) Detaching of tubing

(1) Push in the release button sufficiently. When doing this, push the collar evenly.

(2) Pull out the tube while holding down the release button so that it does not come out. If the release button is not pressed down sufficiently, there will be increased bite on the tube and it will become more difficult to pull it out.

(3) When the removed tube is to be used again, cut off the portion which has been chewed before re-using it. If the chewed portion of the tube is used as is, this can cause trouble such as air leakage or difficulty in removing the tube.

4. Connecting products with attached metal rods

After attaching products with attached metal rods such as the KC series, to the one-touch fitting, do not use tubes, resin plugs, or reducers, etc. This may cause releasing.

5. When mounting tubes, resin plugs, metal rods etc., do not press the release button.

Also, do not press the release button unnecessarily before mounting them. This may cause those parts to come off.

#### Recommended piping conditions

1. When installing piping in the one-touch fitting, make sure there is sufficient slack to the tube length as per the recommended piping conditions shown in Figure 1.

Also, when binding pipes together with a unifying band, etc., make sure piping is carried out without receiving external force. (See Fig. 2.)

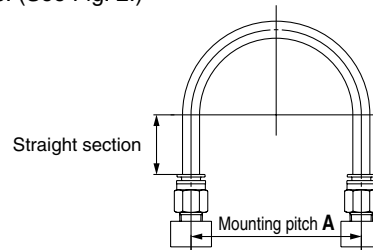

Fig. 1 Recommended piping

Unit: mm

Tube size	Mounting pitch A			Straight section
	Nylon tube	Soft nylon tube	Polyurethane tube	
$\phi 6$	84 or more	39 or more	39 or more	30 or more
$\phi 8$	112 or more	58 or more	52 or more	40 or more
$\phi 10$	140 or more	70 or more	69 or more	50 or more
$\phi 12$	168 or more	82 or more	88 or more	60 or more
$\phi 1/4"$	89 or more	56 or more	57 or more	32 or more
$\phi 5/16"$	112 or more	58 or more	52 or more	40 or more
$\phi 3/8"$	134 or more	76 or more	69 or more	48 or more
$\phi 1/2"$	178 or more	118 or more	93 or more	64 or more

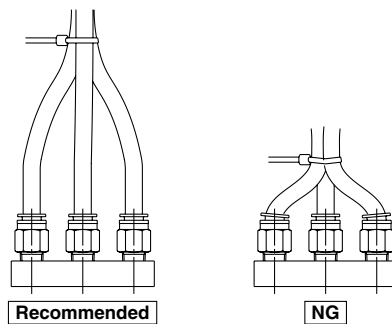

Fig. 2 When using a unifying band to bind together the pipes

### Precautions on Other Tubing Brands

#### ⚠ Caution

1. When using tubing brands other than SMC, confirm that the tube outside diameter tolerances satisfy the following specifications.

- 1) Nylon tube within  $\pm 0.1$  mm
- 2) Soft nylon tube within  $\pm 0.1$  mm
- 3) Polyurethane tube within +0.15 mm, within -0.2 mm

If the tube O.D. accuracy is satisfactory but measurement of the internal diameter dimensions does not match the dimensions provided by SMC, do not use.

The tube may not connect, or leaks, tube disconnection, or damage to fittings may occur.