

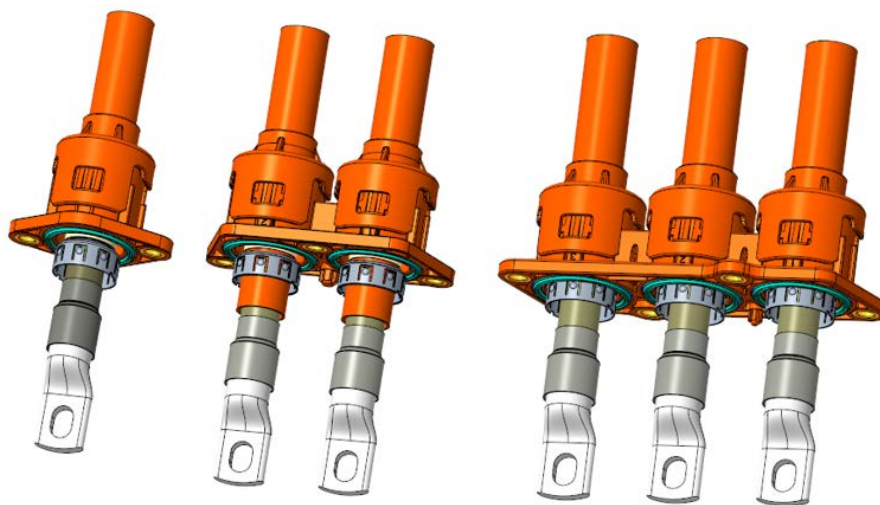

**IPT-HD 50~70mm²
(high current screwed connector sealed)**

Application Specification

IPT-HD 50~70mm²产品应用规范



				PR: K.SI DATE:23DEC2020	 TE Connectivity Shanghai, China		
				CHK: F.MA DATE: 23DEC2020			
A	Initial Released	K.S	23DEC2020	APP: E.JIANG DATE: 23DEC2020		Document No.: 114-160083	LOC: ES
LTR	REVISION RECORD	PR	DATE				



CONTENT 目录

1. SCOPE 适用范围	3
1.1 Content 内容	3
1.2 Processing notes 加工说明	3
2. APPLICABLE DOCUMENTS 适用文件	3
2.1 TE Connectivity Documents 泰科电子文件	3
2.1.1 Customer drawings 客户图纸	3
2.1.2 Specifications 规范	4
2.2 General Documentation 通用文档	4
2.2.1 Cable Specification 线缆规格	4
3. CONDITION OF DELIVERY AND PACKAGING 交货和包装状态	5
3.1 Components 零部件	5
3.2 Packaging and Storage 包装和贮存	7
4. APPLICATION TOOLS 应用工装	7
4.1 IPT-HD 50mm ² /70mm ² ring tongue 应用工装	8
4.2 Shielding 屏蔽	8
5. ASSEMBLY INSTRUCTIONS 组装说明	8
5.1 Overview of all parts should be assembled 全部部件总览图	9
5.2 Shielding Wire assembly process 屏蔽组装制程	10
5.3 Mounting instructions for the IPT-HD 安装说明	13
6. FINAL EXAMINATION 终检	15
6.1 Visual Examination 外观检查	15
6.2 Electrical Tests 电气测试	15
6.2.1 On-line electrical test 在线测试	16
7. APPENDIX 附录	16
7.1 Coroplast No. 9-2611 50 to 70mm ²	16
克洛普 50 到 70 平方屏蔽线	16



- ◆ This connector is intended for use in high-voltage applications. Special care must be applied to ensure that the connector functions as intended.
- ◆ If you suspect that the connector has been modified, damaged, contaminated or otherwise compromised, please discontinue its use immediately.
- ◆ This connector should only be serviced by a trained and qualified technician.

1. SCOPE 适用范围

1.1 Content 内容

This specification covers the requirements for application of the sealed IPT-HD High Voltage connector. The IPT-HD connector system is designed to meet LV215-1 specifications and for a metric wire size range of 50mm² up to 70mm² (acc. to LV216-2). The connector incorporates conductive EMI shields to reduce radiated emissions in the application. The housings are molded in orange to denote a high voltage system.

该规范涵盖了密封IPT-HD 50~70 mm² 高压连接器的应用要求。IPT-HD连接器系统的设计符合LV215-1规范，公制线径范围为50mm²至70mm²（符合LV216-2标准）。该连接器采用导电EMI屏蔽，以减少应用中的辐射。外壳采用橙色模制，表示高压系统。

1.2 Processing notes 加工说明

The processor is responsible for ensuring the quality of the manufacturing process and the proper function of the system. The warranty and liability is excluded, if quality deficiency or damages occurs by failing compliance to this specification or using not specified, not released tools or not released connector components.

加工者负责确保制造过程的质量和系统的正常功能。如果由于未遵守本规范或使用未定义的、未发布的工装或未发布的连接器组件而导致质量异常或损坏，则不承担保修和责任。

2. APPLICABLE DOCUMENTS 适用文件

The following mentioned documents are part of this specification. If there is a conflict between the information contained in the documents and this specification or with any other technical documentation supplied, the last valid customer drawings takes preference.

以下提到的文件是本说明书的一部分。如果文档中包含的信息与本规范或提供的任何其他技术文档之间存在冲突，则最新有效的客户图纸优先。

2.1 TE Connectivity Documents 泰科电子文件

This Application Specification based on the latest valid customer drawings.

本应用规范基于最新的有效客户图纸。

2.1.1 Customer drawings 客户图纸



Component List/ Drawing No.	
2371019	1pos Ring Tongue, Housing, Assy, Sealed
2371017	2pos Ring Tongue, Housing, Assy, Sealed
2355146	3pos Ring Tongue, Housing, Assy, Sealed
2355153	Protective cover
2355153	Shielding sleeve
2355150	Shielding
2355151	Single wire seal
2177380	50sqmm wire Ring tongue
2365737	70sqmm wire Ring tongue

Table 1: Customer drawings 客户图纸

2.1.2 Specifications 规范

Specifications	Description
108-160140	Product Specification 1,2,3 pos IPT-HD 50,70 mm ²
114-160083	Application Specification 1,2,3 pos IPT-HD 50, 70 mm ²

Table 2: TE-specifications / 泰科规范

2.2 General Documentation 通用文档

2.2.1 Cable Specification 线缆规格

Cable specifications of tested high voltage (HV)cables, shielded

Supplier: COROPLAST (Part No.:9-2611/50mm²)

Cross-section: 50mm²

Core diameter: 12.2mm(-0.7)

Outer diameter: 15.8+0/-0.6

Supplier: COROPLAST (Part No.:9-2611/70mm²)

Cross-section: 70mm²
 Core diameter: 14.4mm(-1.4)
 Outer diameter: 18.2+0/-0.8

If the listed wires do not meet your requirements, please contact the responsible TE Connectivity staff.
 如果上面列出的线缆不能满足你的需求，请联系TE的相关人员。

3. CONDITION OF DELIVERY AND PACKAGING 交货和包装状态

3.1 Components 零部件

Table 3 shows the required components for assembly of IPT-HD 1POS







Description 描述	Picture for ref. 图片	Usage 用量	PN for 70mm ² 70 平方线部件号	PN for 50mm ² 50 平方线部件号
1pos Ring Tongue, Housing Assy with dust cover		1	2371019-1	
1pos Ring Tongue, Housing Assy		1	2371019-2	
Protective cover		1	2355153-1	2355153-2
Shielding sleeve		1	2355148-1	2355148-2
Shielding		1	2355150-2 plating Sn 2355150-5 plating Ag	2355150-4 plating Sn 2355150-6 plating Ag
Single wire seal		1	2355151-1	2355151-2
Ring tongue		1	2365737-1	3-2177380-1
heat-shrinkable tubing		N/A	5039254029	

Table 2 shows the required components for assembly of IPT-HD 2POS

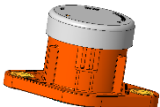
Description 描述	Picture for ref. 图片	Usage 用量	PN for 70mm ² 70 平方线部件号	PN for 50mm ² 50 平方线部件号
2pos Ring Tongue, Housing Assy with dust cover		1	2371017-1	
2pos Ring Tongue, Housing Assy		1	2371017-2	
Protective cover		2	2355153-1	2355153-2
Shielding sleeve		2	2355148-1	2355148-2
Shielding		2	2355150-2 plating Sn 2355150-5 plating Ag	2355150-4 plating Sn 2355150-6 plating Ag
Single wire seal		2	2355151-1	2355151-2
Ring tongue		2	2365737-1	3-2177380-1
heat-shrinkable tubing		N/A	5039254029	

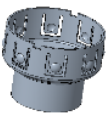
Table 3 shows the required components for assembly of IPT-HD 3POS

Description 描述	Picture for ref. 图片	Usage 用量	PN for 70mm ² 70 平方线部件号	PN for 50mm ² 50 平方线部件号
3pos Ring Tongue, Housing Assy with dust cover		1	2355146-1	
3pos Ring Tongue, Housing Assy		1	2355146-2	
Protective cover		3	2355153-1	2355153-2
Shielding sleeve		3	2355148-1	2355148-2
Shielding		3	2355150-2 plating Sn 2355150-5 plating Ag	2355150-4 plating Sn 2355150-6 plating Ag
Single wire seal		3	2355151-1	2355151-2
Ring tongue		3	2365737-1	3-2177380-1
heat-shrinkable tubing		N/A	5039254029	

3.2 Packaging and Storage 包装和贮存

The products should be used on a “first in, first out” basis to avoid storage contamination, see latest valid customer drawings too.

为避免存储污染，产品应以“先进先出”的原则使用，也请参见最新的有效客户图纸。

4. APPLICATION TOOLS 应用工装

The Application tools are only valid for the specified cables at appendix. More tooling information can be



obtained through a local TE Representative, or after purchase, by calling the product information Center.

应用工装仅对附录中的指定电缆有效。可通过当地TE代表获取更多工装信息，或者在购买后，拨打产品信息中心电话。

4.1 IPT-HD 50mm²/70mm² ring tongue应用工装

Table 4. Required application tools contact crimp

Application tools / 应用工装	
2359763-1	Ring Tongue, IPT-HD 70mm ² crimp tool
2351901-1	Ring Tongue, IPT-HD 50mm ² crimp tool

4.2 Shielding 屏蔽

The following table contains the required order numbers for application tools.

下表包含所需应用工装的订货号。

Table 5: Application tools

Application tools / 应用工装	
2359742-1	Shield crimp tool for 70mm ² cable
2359741-1	Shield crimp tool for 50mm ² cable

5. ASSEMBLY INSTRUCTIONS 组装说明

The following procedures show the details of the cable assembly and insertion instructions of the cable assembly into the plug housing subassembly. The processing is only valid for the specified cable at appendix and only these combinations have been validated by TE. Alternative cables may be used after ensuring performance through validation testing.

下述步骤显示了线缆组件的细节和线缆组件插入母端壳体子组件的插入说明。该制程仅对附录中的指定线缆有效，并且仅这样的组合通过TE验证。在通过验证测试性能之后，可以使用替代电缆。

5.1 Overview of all parts should be assembled 全部部件总览图

Component of IPT-HD 1P 50mm² & 70mm² review

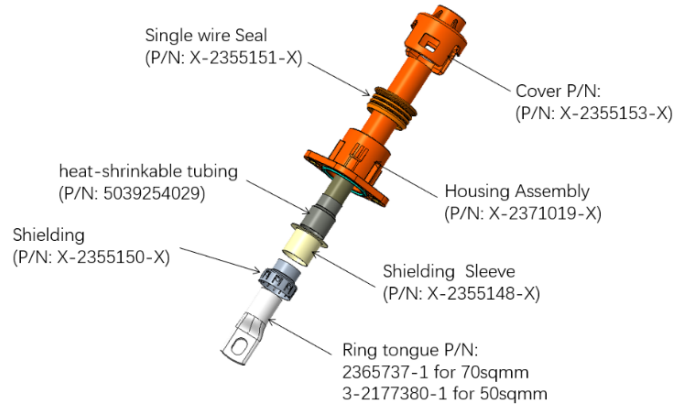

Figure 1

Component of IPT-HD 2P 50mm² & 70mm² review

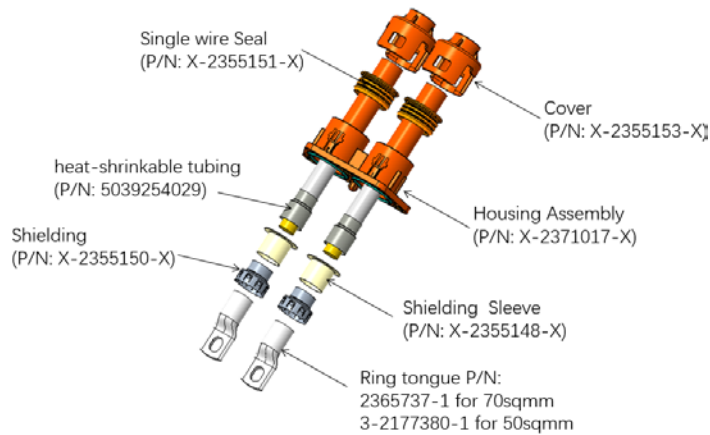

Figure 2

Component of IPT-HD 3P 50mm² & 70mm² review

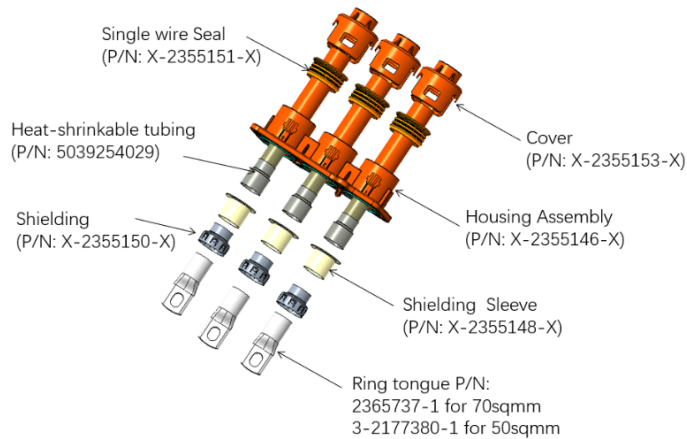

Figure 3

5.2 Shielding Wire assembly process 屏蔽组装制程

Safety information, avoid prolonged or repeated skin with conductor or shieldings (wear protective gloves). Please note, the procedure of assembly the shielded cable is provided in two documents, the following steps shows the assembly without contact processing.

安全提醒，避免皮肤长时间或重复与导体或屏蔽接触（戴防护手套）。
请注意，屏蔽线缆的组装步骤在两个文档中提供，以下组装步骤不包含端子。

Step 1/步骤一 In order shown in figure 4, slide cover ,seal assy and Shield sleeve onto cable sheath, they are not in crimp work area.

按照图4所示的顺序，滑动保护盖，密封件和屏蔽套管到电缆护套上，使它们不在压接区域。

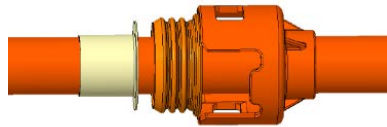

Figure 4: Before processing slide components onto cable

Step 2/步骤二 Strip and remove outer insulation wall, screening braid (if present screening foil), inner insulation wall and conductor from the end as shown in figure 4.

Stripping dimensions for exposing wire follow below table7

如图4所示，切开并去除外绝缘皮，屏蔽编织物（如果存在屏蔽箔），内绝缘皮和导体。
剥线尺寸如下表要求

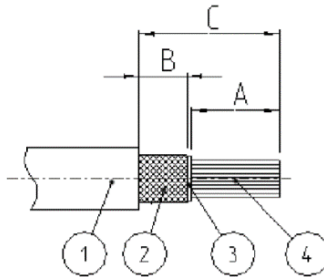

Figure 5 Cutting cable to length



Attention: Cable sheath and shielding braid shall not be cut or broken during the cutting procedure.
注意：切割过程中不得切割或破坏电缆护套和屏蔽编织层。

1000VDC 70mm ²					
(ID)	Cable Design	A [mm]	B [mm]	C [mm]	C-A [mm]
1	Outer sheath	--	--	48±0.5	
2	Screening braid	--	(8)	--	
3	Inner insulation wall	--	--	--	(27)
4	Conductor	21±1	--	--	

Table 6: Cutting dimensions 剥线尺寸for 70mm²

1000VDC 50mm ²					
(ID)	Cable Design	A [mm]	B [mm]	C [mm]	C-A [mm]
1	Outer sheath	--	--	50±0.5	
2	Screening braid	--	(8)	--	
3	Inner insulation wall	--	--	--	(34)
4	Conductor	16±1	--	--	

Table 7: Cutting dimensions 剥线尺寸for 50mm²

Step 3/步骤三 assemble shielding 组装屏蔽环

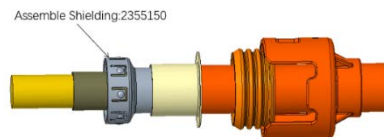

Figure 6: assemble shielding

Step 4/步骤四 assemble and crimp ring tongue per to table 8 组装并压接端子尺寸按照表8



Figure 7: ring tongue crimp

Wire size	CH	CB	
50mm ²	7.3+/-0.10	14.60Max.	
70mm ²	10.55+/-0.10	16.45Max.	

Table 8: ring tongue crimp height 端子压接高度

Step 5/步骤五 Raising and smooth screening braid equally over shielding ferrule. 翻起和捋屏蔽细丝均匀的覆盖在屏蔽环上

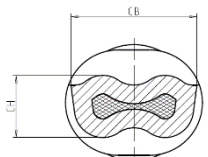
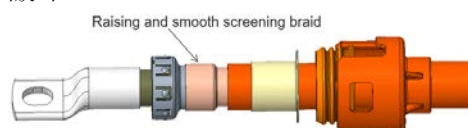

Figure 9: Raising and smooth screening braid

Step 6/步骤6 assemble shielding sleeve over screening braid and shielding ferrule.
 组装屏蔽套筒覆盖编织线和屏蔽环

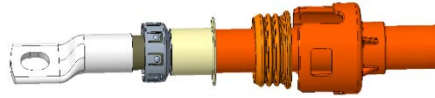

Figure 10: assemble shielding sleeve

Step 7/步骤7 crimp shielding 压接屏蔽环

Adjust dimension L insure that shield and isolation crimping fixture meet cable assembly specification, then position and crimp the cable assembly (Figure 8, 19).
 调整L的尺寸到合适的位置后，压接shielding和shielding sleeve

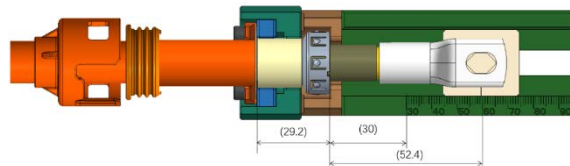

Figure 11: location and crimp shielding

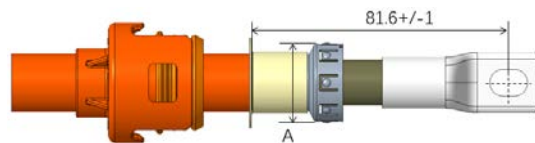

Figure 12: confirm shielding to ring tongue and flange distance



Figure 13: shielding crimp Height and Width

Crimp dimension					
COROPLAST	50mm ²	14.9 ± 0.1	15.5 ± 0.2	24Max	24.75Max
COROPLAST	70mm ²	17.55 ± 0.1	17.95 ± 0.2	24Max	24.75Max
Supplier	Size	Shielding CH	Insulation CH	CB	DIM A Shielding Diametre

Table 9: shielding crimp height

⚠ It is essential that there are no mistakes in this step because there will be no chance to re-work the parts.
在这一步中没有错误是至关重要的，因为无法重新加工。

The following items at minimum must be inspected and verified, before and after shield crimp process.

- All components are present, and parts are crimped in correct orientation and location
- No visible cracking of the shielding parts and no loose cable shield strands
- Shielding crimp dimensions per to table 7
- Excess length of screening braid must be visible max. 5mm
- Allocation of screening braid should be equal over perimeter
- After shielding crimp, Shielding diameter can not exceed 24.75Max

在屏蔽压接前后，必须至少检查并验证以下项目：

- 所有部件完整，部件以正确的方向和位置进行压接
- 屏蔽部件没有明显的开裂，也没有松散的电缆屏蔽线
- 屏蔽压接按照表7
- 屏蔽编织的长度必须可见最大1毫米
- 屏蔽编织应该均匀分配在四周
- 压接后，屏蔽环直径不能超过24.75mm

Step 8/步骤8 Heating seal heat-shrinkable tubing, Reference Part NO. :5039254029
热封热缩套管,参考料号5039254029

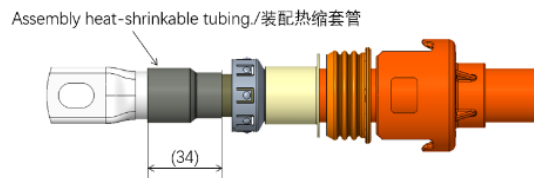

Figure 14 Heating seal heat-shrinkable tubing

5.3 Mounting instructions for the IPT-HD 安装说明

Step 1/步骤1 Assemble housing assembly in system by M6 bolt, reference tightening torque $8.0 \pm 1\text{Nm}$
用推荐M6的螺钉将塑胶装配到系统面板上，参考安装扭矩螺钉扭矩 $8.0 \pm 1\text{Nm}$

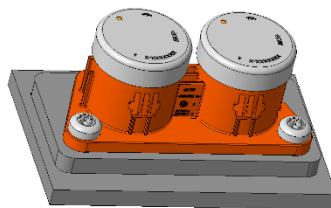

Figure 15 Assemble housing assembly

Step 2/步骤2 Remove the cover/ 将盖子去除。

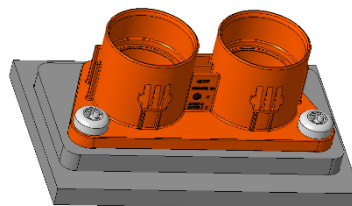

Figure 16 Remove the cover

Attention: There will be some slight trace on out of housing during the remove the cover, these slight trace do not affect the function.

注意： 在去除盖子的过程中，塑胶的外侧可能会出现一些轻微的划痕，这些划痕将不会影响产品功能。

Step 3/步骤3

Assemble the harness to the housing assembly, assembly single wire seal and / housing cover
将线束插入到塑胶内

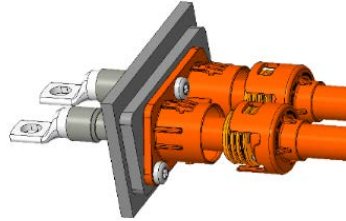

Figure 17 Assemble the harness

Step 4/步骤4

Lock housing cover and single wire seal at housing assembly.
将塑胶盖子和密封圈锁在塑胶上。

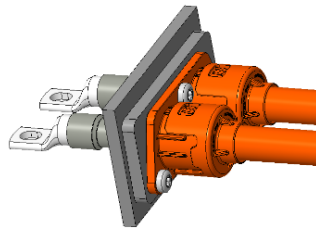

Figure 18 Lock housing cover

Step 5/步骤5

Ring tongue to diecasting Distance check, Recommend bolt :M8 tightening torque: 15+/-1.5Nm
将端子和busbar连接。推荐安装M8 螺栓 扭矩：15+/-1.5Nm

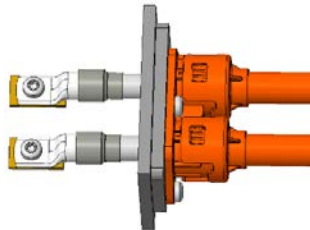

Figure 19 Screw the ring tongue to the busbar

5.4 Mounting Dimension illustration 安装尺寸说明

D: Ring tongue centerline distance to shielding flange 端子中心到屏蔽法兰环距离

E: Ring tongue centerline distance to diecasting surface 端子中心到应用面板距离

F: Diecasting thickness 应用界面的厚度

G: Housing mounting surface distance to shielding flange (17.6) 塑胶安装面到法兰环距离 (17.6)

$$D=E+F+G$$

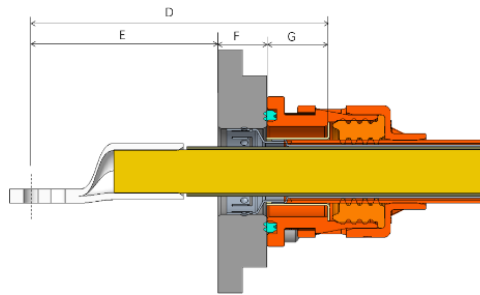

Figure 20 Mounting Dimension illustration

DIM D will be adjust by application High Voltage value 取决于应用电压值

For example, with 1000DC application, DIM.E must be 50Min. can meet Electrical clearance and creepage
 例如，在1000DC应用下，为保证安全的爬电和电气间隙，尺寸E 必须满足最小50

DIM E: 50 (Depend on 1000DC application)

DIM F: 14

DIM G: 17.6

DIM D= E+F+G=50+14+17.6=81.6



If Voltage 1000VDC Max and interface thickness 14 can not meet your application, please contact the responsible TE Connectivity staff. Cable assemble dimension will be adjust and recommend again.

如果电压1000VDC 最大和板厚14不能满足你的应用,请联系TE工作人员,会重新推荐压接线束的尺寸。

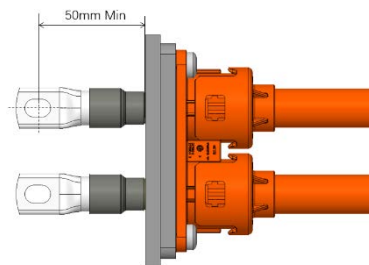

Figure 21 Application 1000VDC Electrical distance requirement

6. FINAL EXAMINATION 终检

6.1 Visual Examination 外观检查

After processing the connector assembly has to be checked of completeness, correctness acc. customer drawings and free of damage.

在装配连接器后，必须根据客户图纸进行完整性、正确性检查，且不能损坏。

6.2 Electrical Tests 电气测试

Electrical characteristic values according product specification TE-108-32326 / chapter 3.4 are ensured by applicator. The test parameter should be not exceeding the values shown in point 3.4/ TE-108-32326.

使用方依据产品规范TE-108-160140第3.4章保证电气特性。测试参数不应超出规范3.4章的值。

6.2.1 On-line electrical test 在线测试

Apply 4000VAC to the test on line samples for 60s using the dielectric withstand tester, record the leakage current.
Leakage current ≤ 10 mA.

施加4000VAC 60s 测试在线样品，记录电流泄漏量 不超过10mA

7. APPENDIX 附录

7.1 Coroplast No. 9-2611 50 to 70mm²

克洛普 50 到 70 平方屏蔽线

Automotive Leitung geschirmt
für elektrische Fahrzeugantriebe

FHLR2GCB2G
50 mm² / 0,21 T180 0,6/1,0 kV

Shielded cable for
automotive electric powertrain

FHLR2GCB2G
50 mm² / 0,21 T180 0,6/1,0 kV

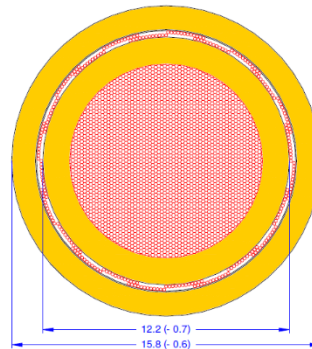

Figure 22 coroplast 50mm²

Automotive Leitung geschirmt
für elektrische Fahrzeugantriebe

FHLR2GCB2G
70 mm² / 0,21 T180 0,6/0,9 kV

Shielded cable for
automotive electric powertrain

FHLR2GCB2G
70 mm² / 0,21 T180 0,6/0,9 kV

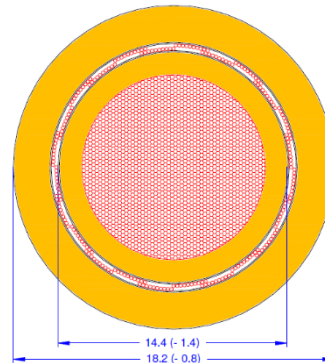

Figure 23 coroplast 70mm²