

Kettenräder KRS mit einseitiger Nabe, ISO 05 B-1

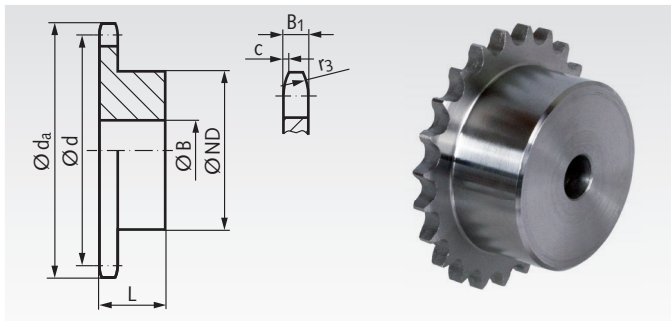

Werkstoff: Kohlenstoffarmer Stahl, nicht härtbar.
Bohrungen vorgebohrt.
Mit 1) versehene Räder aus St52 mit eingeschweißter Nabe.

Bestellangaben: z.B.: Art.-Nr. 100 808 00, KRS, ISO 05 B-1, 8 Zähne

ISO 05 B-1, Teilung 8 mm

$B_1 = 2,8 \text{ mm}$, $c = 1,0 \text{ mm}$, $r_3 = 8 \text{ mm}$

Artikel-Nr.	Zähnezahl	d_a mm	d mm	ND mm	B mm	L mm	Gewicht g
100 808 00	8	24,0	20,90	13	6	12	12
100 809 00	9	26,6	23,39	15	6	12	17
100 810 00	10	29,2	25,89	17	8	12	21
100 811 00	11	31,7	28,39	18	8	13	25
100 812 00	12	34,2	30,91	20	8	13	33
100 813 00	13	36,7	33,42	23	8	13	43
100 814 00	14	39,2	35,95	25	8	13	53
100 815 00	15	41,7	38,48	28	8	13	66
100 816 00	16	44,3	41,01	30	8	14	81
100 817 00	17	46,8	43,53	30	8	14	83
100 818 00	18	49,3	46,07	30	8	14	88
100 819 00	19	51,9	48,61	30	8	14	93
100 820 00	20	54,4	51,14	30	8	14	97
100 821 00	21	57,0	53,68	35	8	14	122
100 822 00	22	59,5	56,21	35	8	14	127
100 823 00	23	62,0	58,75	35	8	14	133
100 824 00	24	64,6	61,29	35	8	14	138
100 825 00	25	67,5	63,83	35	8	14	141
100 826 00	26	69,5	66,37	40	10	16	189
100 827 00	27	72,2	68,91	40	10	16	193
100 828 00	28	74,8	71,45	40	10	16	202
100 829 00	29	77,3	73,99	40	10	16	204
100 830 00	30	79,8	76,53	40	10	16	215
100 831 00	31	82,4	79,08	40	10	16	210
100 832 00	32	84,9	81,61	40	10	16	220
100 833 00	33	87,5	84,16	40	10	16	224
100 834 00	34	90,0	86,70	40	10	16	230
100 835 00	35	92,5	89,25	40	10	16	236
100 836 00	36	95,0	91,79	40	10	16	245
100 837 00	37	97,6	94,33	40	10	16	253
100 838 00	38	100,2	96,88	40	10	16	267
100 839 00	39	102,7	99,42	40	10	16	270
100 840 00	40	105,3	101,97	40	10	16	283
100 845 00	45	118,0	114,69	60	12	20	575
100 848 00	48	125,6	122,32	60	12	20	605
100 850 00	50	130,7	127,41	60	12	20	625
100 857 00	57 ¹⁾	148,6	145,22	80	14	20	990
100 860 00	60 ¹⁾	156,2	152,85	80	16	34	1535
100 876 00	76 ¹⁾	197,7	193,59	80	20	25	1415

Kettenradscheiben KRL ohne Nabe, ISO 05 B-1

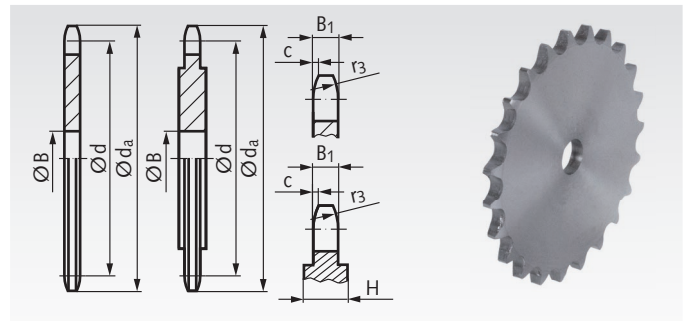

Werkstoff: Kohlenstoffarmer Stahl, nicht härtbar.
Bohrungen vorgebohrt.
Teilung 8 mm KRL ab Zz 48 wird verstärkt geliefert (H = 4 mm, siehe Zeichnung).

Bestellangaben: z.B.: Art.-Nr. 100 908 00, KRL, ISO 05 B-1, 8 Zähne

ISO 05 B-1, Teilung 8 mm

$B_1 = 2,8 \text{ mm}$, $c = 1,0 \text{ mm}$, $r_3 = 8 \text{ mm}$

Artikel-Nr.	Zähnezahl	d_a mm	d mm	B mm	Gewicht g
100 908 00	8	24,0	20,90	6	5
100 909 00	9	26,6	23,39	6	6
100 910 00	10	29,2	25,89	8	9
100 911 00	11	31,7	28,39	8	10
100 912 00	12	34,2	30,91	8	13
100 913 00	13	36,7	33,42	8	15
100 914 00	14	39,2	35,95	8	18
100 915 00	15	41,7	38,48	8	21
100 916 00	16	44,3	41,01	8	24
100 917 00	17	46,8	43,53	8	28
100 918 00	18	49,3	46,07	8	32
100 919 00	19	51,9	48,61	8	36
100 920 00	20	54,4	51,14	8	41
100 921 00	21	57,0	53,68	10	42
100 922 00	22	59,5	56,21	10	48
100 923 00	23	62,0	58,75	10	53
100 924 00	24	64,6	61,29	10	59
100 925 00	25	67,5	63,83	10	64
100 926 00	26	69,5	66,37	10	65
100 927 00	27	72,2	68,91	10	71
100 928 00	28	74,8	71,45	10	81
100 930 00	30	79,8	76,53	10	93
100 932 00	32	84,9	81,61	10	105
100 935 00	35	92,5	89,25	10	122
100 936 00	36	95,0	91,79	10	137
100 938 00	38	100,2	96,88	12	149
100 940 00	40	105,3	101,97	12	173
100 942 00	42	110,4	107,05	12	191
100 945 00	45	118,0	114,69	12	211
100 948 00	48	125,6	122,32	12	340
100 950 00	50	130,7	127,41	12	354
100 954 00	54	140,9	137,59	16	420
100 957 00	57	148,6	145,22	16	475
100 960 00	60	156,2	152,85	16	507
100 965 00	65	169,6	165,58	16	620
100 970 00	70	182,4	178,31	16	680
100 976 00	76	197,7	193,59	20	836
100 980 00	80	207,9	203,77	20	941
100 983 00	95	246,1	241,96	20	1341
100 988 00	114	294,5	290,33	20	1992

Kettenräder aus rostfreiem Stahl Seite 72.

**Anschraubnaben für
Kettenradscheiben Seite 105**

