

Single-in-Line SIL/SIP Reed Relays

Very high packing density

1 Form A stacks on 0.15 x 0.27 inches pitch

Products highlighted  are available from Rapid Electronics www.rapidonline.com

Features

- **SoftCenter®** construction (see adjacent diagram)
- Highest quality instrumentation grade switches
- Plastic package with internal mu-metal magnetic screen
- They take up the minimum of board area, conserving board space
- Insulation resistance greater than $10^{12} \Omega$
- 3 or 5 Volt coils with or without internal diode
- 100% tested for dynamic contact resistance for guaranteed performance

The Pickering Series 117 is a range of Single-in-Line relays intended for very high density applications such as A.T.E. switching matrices or multiplexers.

They are available with either 1 or 2 Form A (energize to make) switches.

Single switch versions require a board area of only 0.15 inches x 0.27 inches. This is one quarter of the board area of the industry standard 0.2 x 0.8 inches Single-in-Line package. The very small size of these relays often makes it possible to increase the functionality of existing designs without increasing the size of printed circuit boards.

The Series 117 switch rating of 5 Watts, 0.5 A is adequate for most instrumentation applications. If a higher rating is required, the Series 116, which is rated at 10 Watts, 0.5 A should be considered. The relay footprint and pin configurations of the Series 116 are identical but the case height increases slightly to 0.49 inches (12.5 mm).

The relays feature an internal mu-metal magnetic screen. Mu-metal has the advantage of a high permeability and low magnetic remanence and eliminates problems that would otherwise occur due to magnetic interaction. Interaction is usually measured as a percentage increase in the voltage required to operate a relay when additional relays, stacked each side, are themselves operated. An unscreened device mounted on this pitch would have an interaction figure of around 40 percent. Relays of this size without magnetic screening would therefore be totally unsuitable for applications where dense packing is required.

3 volt and 5 volt coils are available with an optional Back E.M.F suppression diode.

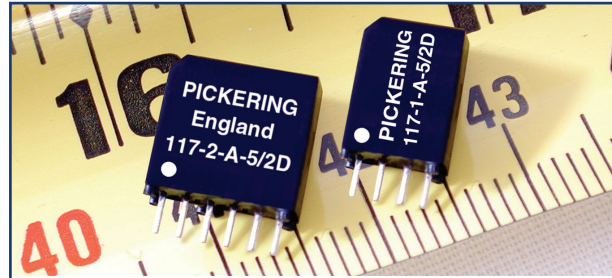

1 Form A	0.26 nom (6.60)	
	0.27 max (6.86)	
2 Form A	0.39 nom (9.90)	0.145 nom (3.70)
	0.40 max (10.16)	0.15 max (3.81)
		0.375 nom (9.52)
		0.385 max (9.78)

Inches (mm)

Pin 1

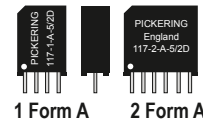

Actual size

Typical Pickering **SoftCenter®** Construction

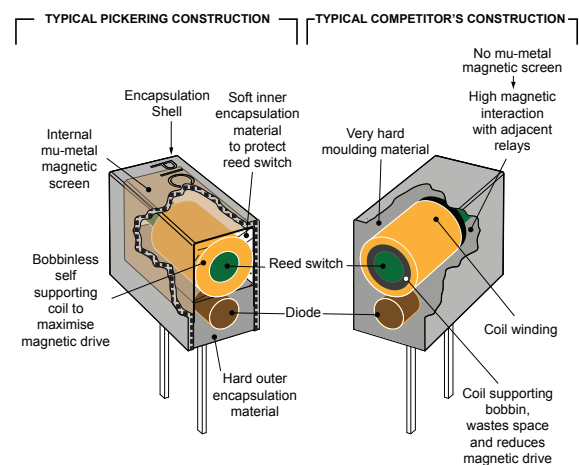

The reed switch in the Series 117 is suitable for low level or 'cold' switching. In accordance with Pickering convention, this switch is referred to as type number 2. There is no general purpose switch (type number 1) currently available in this series, but the type 2 is suitable for all applications if it is used within its specified ratings. This means that high inrush currents, particularly caused by capacitive loads must be avoided.

Series 117 switch ratings - The contact ratings for each switch type are shown below:

Switch No	Switch form	Power rating	Max. switch current	Max. carry current	Max. switching volts	Life expectancy ops typical (see Note ¹ below)	Operate time inc bounce (max)	Release time	Special features
2	A	5 W	0.5 A	0.5 A	170	10E8	0.3 ms	0.15 ms	All applications

Operating voltages

Coil voltage - nominal	Must operate voltage - maximum at 25°C	Must release voltage - minimum at 25°C
3 V	2.25 V	0.3 V
5 V	3.75 V	0.5 V

Coil data and type numbers

Device type	Type Number	Coil (V)	Coil resistance	Max. contact resistance (initial)	Insulation resistance (minimum)		Capacitance (typical) (see Note ^{2,3} below)	
					Switch to coil	Across switch	Closed switch to coil	Across open switch
1 Form A (energize to make) Switch No. 2	117-1-A-3/2D	3	200 Ω	0.12 Ω	10E12 Ω	10E12 Ω	2.0 pF	0.14 pF
	117-1-A-5/2D	5	400 Ω	0.12 Ω	10E12 Ω	10E12 Ω	2.0 pF	0.14 pF
2 Form A (energize to make) Switch No. 2	117-2-A-5/2D	5	250 Ω	0.12 Ω	10E12 Ω	10E12 Ω	2.0 pF	0.14 pF

When an internal diode is required, the suffix D is added to the part number as shown in the table.

Environmental specification

Standard operating temperature range: -20 to +85 °C.
 Note: The upper temperature limit can be extended to +125 °C if the coil drive voltage is increased to accommodate the resistance/temperature coefficient of the copper coil winding. This is approximately 0.4% per °C. This means that at 125 °C the coil drive voltage will need to be increased by approximately 40 x 0.4 = 16% to maintain the required magnetic drive level. Please contact sales@pickeringrelay.com for assistance if necessary.
Vibration: Maximum 20 G **Shock:** Maximum 50 G

Note¹ Life expectancy

The life of a reed relay depends upon the switch load and end of life criteria. For example, for an 'end of life' contact resistance specification of 1 Ω, switching low loads (10 V at 10 mA resistive) or when 'cold' switching, typical life is approx 2.5 x 10⁸ ops. At the maximum load (resistive), typical life is 1 x 10⁶ ops. In the event of abusive conditions, e.g. high currents due to capacitive inrushes, this figure reduces considerably. Pickering will be pleased to perform life testing with any particular load condition.

Note² Switch to coil capacitance

Due to the asymmetrical internal construction of the relay, the capacitance to the coil from one switch connection is approximately half the capacitance of the other switch connection, for the 1 Form A versions pin 3 is lower. In some applications this feature may be used to advantage for example, in a multiplexer where it is desirable to minimize the capacitance of the common connection to maximize bandwidth.

Note³ Capacitance across open switch

The capacitance across the open switch was measured with other connections guarded.

Example of Packing Density - Actual Size

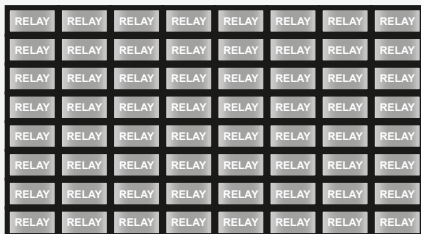

In this small area of only 2.16 x 1.2 inches (5.48 x 3.05 cm), it is possible to construct an 8 x 8 matrix - 64, 1 Form A relays.

Main contact:

UK Headquarters: email: sales@pickeringrelay.com | Tel. +44 1255 428141

Worldwide contacts:

USA: email: ussales@pickeringtest.com | Tel. +1 781 897 1710

Germany: email: desales@pickeringtest.com | Tel. +49 89 125 953 160

China: email: johnson@tomtech.cn | Tel. 0755 8374 5452

For a full list of agents and representatives visit: pickeringrelay.com/agents



ISO9001 Manufacture of Reed Relays FM 29036



Pin Configuration and Dimensional Data

Dimensions in Inches (Millimeters in brackets)

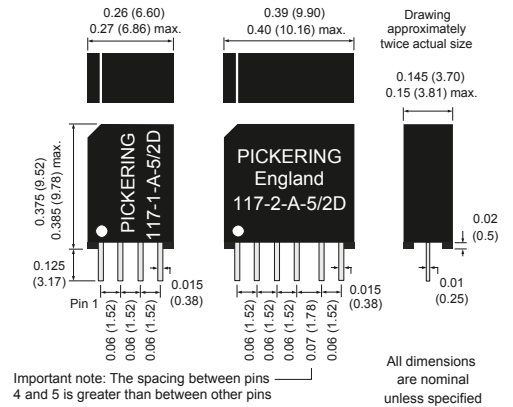

Important note: The spacing between pins 4 and 5 is greater than between other pins



Note⁴: Pin 3 is round with an outer diameter of 0.016 (0.4).
Note⁵: Pins 4 and 5 are round with an outer diameter of 0.016 (0.4).

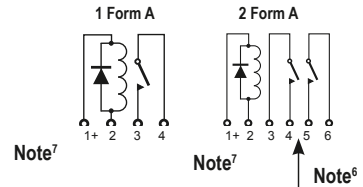

Note⁶: The spacing between pins 4 and 5 is greater than between other pins.
Note⁷: When an optional diode is fitted pin 1 is the positive connection.

3D Models: Interactive models of the complete range of Pickering relay products can be downloaded from the web site.

Internal Mu-metal Magnetic Screen

The Series 117 relays are fitted with an internal mu-metal magnetic screen which permits side-by-side stacking on 0.15 inches pitch.

Order Code

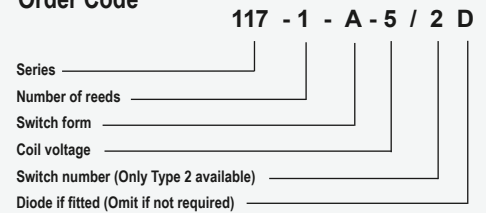

Help

If you need any technical advice or other help, for example, any special tests that you would like carried out, please do not hesitate to contact our Technical Sales Department. We will always be pleased to discuss Pickering relays with you. email: techsales@pickeringrelay.com

Please ask us for a FREE evaluation sample.