

Modular standard power units

RE 51098/06.05
Replaces: 51097

1/32

Type ABMAG

Component series 2X
 Reservoir capacity 100 to 800 litres
 Maximum nominal pressure 280 bar
 Maximum flow 200 L/min

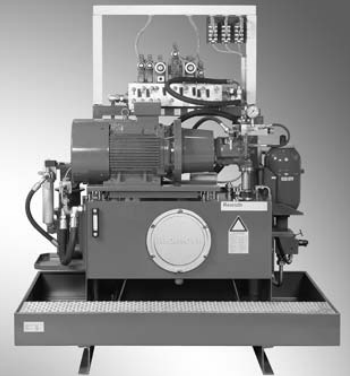

016-04_d

Table of contents

Contents	Page
Features	1
Circuit diagram	2
Power unit structure ABMAG	3
Ordering code	4
Order example ABMAG	5
Technical data	6
Selection table: Reservoir sizes for pump/motor group	7 to 9
Circuit diagram of basic power unit ABMAG	10 to 12
Return line filter for basic power units, filter clogging indicator	13
Options	14
• Float switch, thermostat, heater	15 to 17
• Filter/cooler circulation circuit	18, 19
• Accumulator station, manual and el. drain valve	20, 21
• Pump safety block with pressure filter	22, 23
• Oil drip tray according to Water Resources Act	24 to 29
• Control assembly IH20	30
Typical noise level values	31
Unit dimensions	32
Engineering and commissioning notes	

Features

- Power units of this series are made up from standard components and modular assemblies. They are suitable as basis for setting up complex controls.
- The basic power unit consists of:
- Reservoir made of steel according to DIN 24339, form AN cover form C
 - Reservoir accessories
 - Return line filter
 - Defined pump/motor group
- The basic version can be extended with the following options:
- Pump safety block with pressure filter
 - Float switch
 - Heater
 - Thermostat
 - Accumulator station type ABSBG
 - Filter/cooler circulation circuit type ABUKG
 - Air cooler assembly KOL/KOLP
 - Control assembly type IH20
 - Electrical wiring
- Modular standard power units are used in the following areas:
- General mechanical engineering
 - Machine tools
 - Assembly stations

Circuit diagram: Power unit type ABMAG

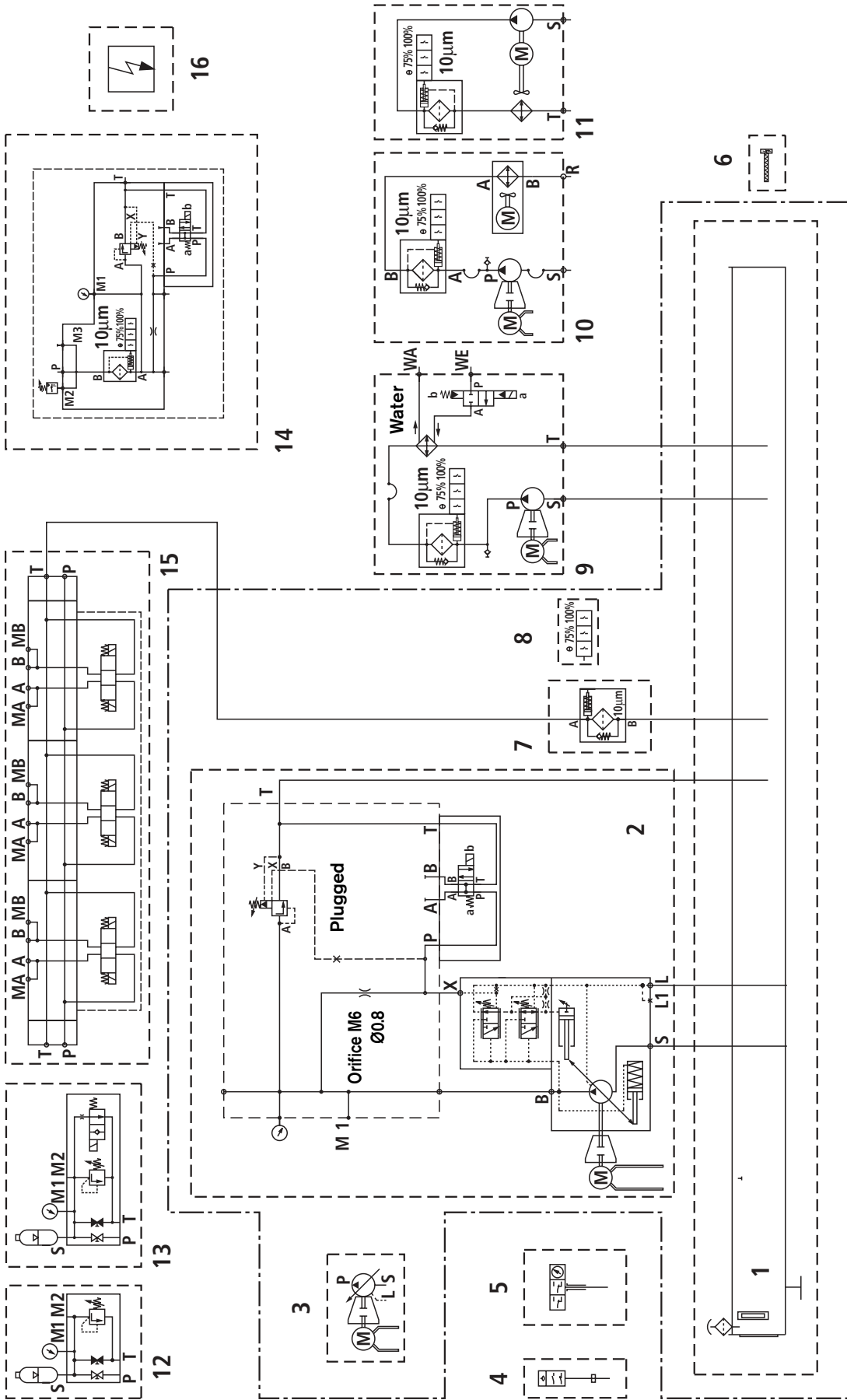

- 1 Fluid reservoir
- 2 Pump/motor group with A10VSO pump
- 3 Pump/motor group with V7 pump
- 4 Float switch
- 5 Thermostat
- 6 Heater
- 7 Return line filter (DIN filter)
- 8 Clogging indicator
- 9 Filter/cooler circulation unit (water)
- 10 Filter/cooler circulation unit (air)
- 11 Filter/cooler circulation unit (air - KOLP)
- 12 Accumulator station, mech. unloading
- 13 Accumulator station, ei. unloading
- 14 Pump safety block with pressure filter (DIN filter)
- 15 Segment design
- 16 Electrical wiring

The individual component assemblies can be made up individually depending on the requirements.

Power unit structure of ABMAG

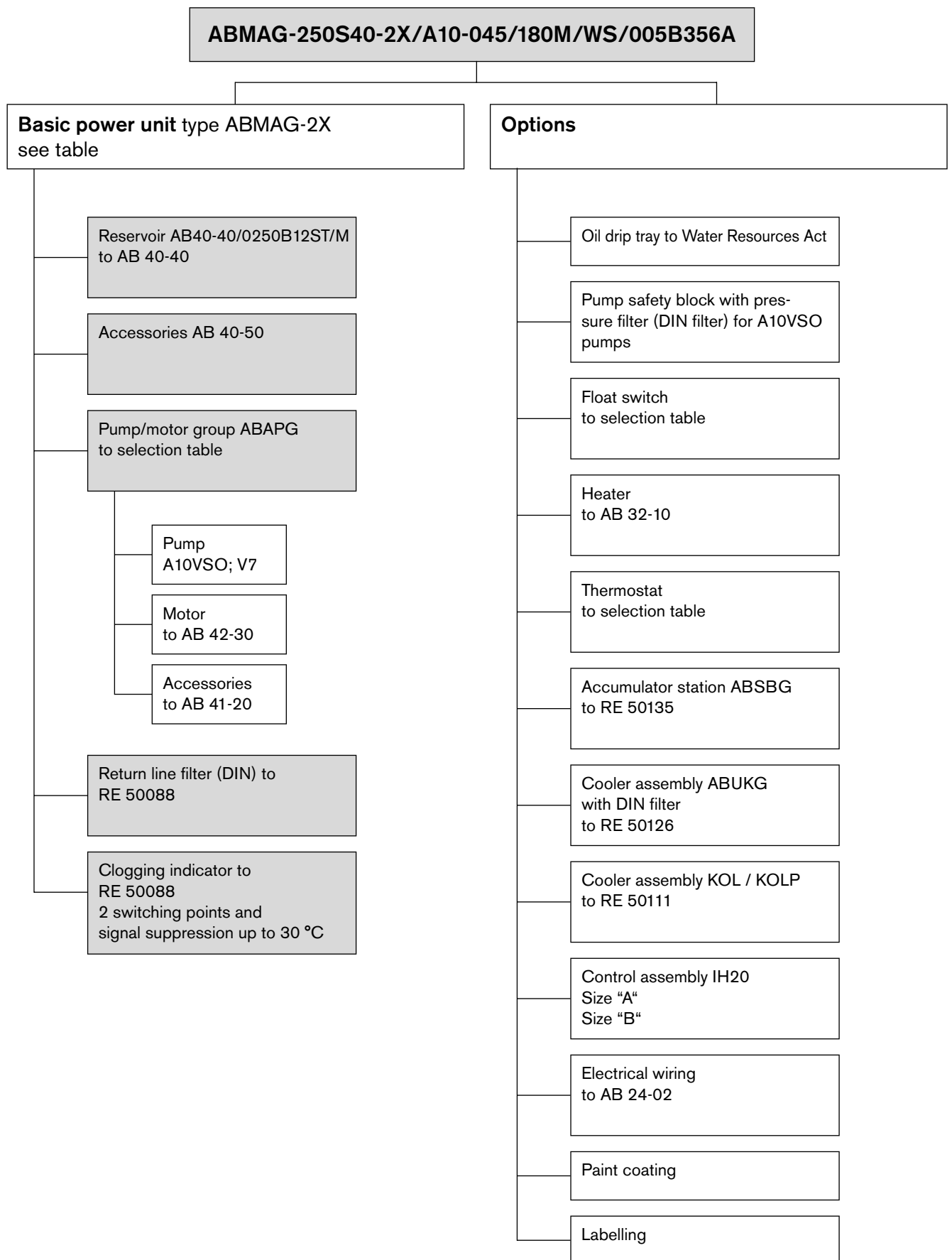

Ordering code

ABMAG	S40	2X	/	/	/	/	/	/
Modular standard power unit type ABMAG								
Reservoir size								
Reservoir capacity 100 litres	= 100							
Reservoir capacity 160 litres	= 160							
Reservoir capacity 250 litres	= 250							
Reservoir capacity 400 litres	= 400							
Reservoir capacity 630 litres	= 630							
Reservoir capacity 800 litres	= 800							
Reservoir material								
Steel, reservoir form to AB 40-40	= S40							
Component series 20 to 29								
(20 to 29 unchanged installation dimensions)		= 2X						
Pump type code								
A10VSO 140		= A10-140						
V7/100-118		= V7-100						
El. motor frame size								
e.g. 132M					= 132M			
With filter/cooler circulation circuit ABUKG						= W		
With oil/air cooler circuit KOL/KOLP						= L		
With accumulator station ABSBG							= S	
Circuit diagram code								
Example:								
Code of sales subsidiary							= 13	
Circuit diagram number								= A487A

Order example:

ABMAG-800S40-2X/A10-140/225M/WS/13A487A

Technical data (for applications outside these parameters, please consult us!)

Pipe connections	Oil side	Connection thread to ISO 1179 Pipe connections to DIN 2353/ ISO 8434, Flanges to ISO 6162
	Water connections	Thread to ISO 228/1
Pump types		A10VSO 18 to data sheet RE 92712 A10VSO 28-140 to data sheet RE 92711 PV 7 to data sheet RE 10515 PVV 18-60 to data sheet RE 10335
Pump/motor group		ABAPG to data sheet RE 51062
Accumulator station		ABSBG to data sheet RE 50135
Filter/cooler circulation circuit		ABUKG to data sheet RE 50126
Air cooler assembly		to data sheet RE 50111
Type of piping		Fitting to DIN 2353 light/heavy series; pipe forming system to AB 20
Hydraulic fluid		Mineral oil (HLP) to DIN 51524 part 2 e.g. at operating temperature of 50 °C ISO VG46 DIN 51519 (other hydraulic fluids on enquiry) Please observe our regulations to data sheet RE 07075!
Hydraulic fluid temperature range	°C	- 20 to + 80 The optimum operating temperature of the power unit for operation with mineral oil HLP to DIN 51524 is between 40° and 50° C. In continuous operation, the operating temperature should not exceed 70° C.
Pressure relief function		Pump pressure relief valve to data sheet RE 25890 for variable displacement pumps of type A10VSO
Cooling medium		Drinking, industrial, stream and river water
Motor voltage / frequency		230/400 Volt or 400/690 V- 50 Hz to IEC 38 460 V - 60 Hz (other voltages on enquiry) design B 35
Pump direction or rotation		Clockwise
Water valve		Electrically operated 2/2 directional water valve to AB 21-23
Viscosity range	mm ² /s	Recommended range for continuous operation 20...100 (see also RE 92711, RE 92712, RE 10515 and RE 10335)
Max. permissible degree of contamination of the hydraulic fluid - cleanliness class to ISO 4406 (c)		Class 21/19/16 ¹⁾
Filter rating	µm	10
Surface protection		1st primer coat: All structural steel parts with zinc dust paint 2nd primer coat: Epoxy basic colour RAL 5010 Control plates and pipes in A3C

¹⁾ The cleanliness classes specified for components must be adhered to in hydraulic systems. Effective filtration prevents malfunction and, at the same time, prolongs the service life of components.

For the selection of filters, see RE 50070,
RE 50076, RE 50081, RE 50086 and RE 50088.

Selection table: Reservoir sizes for pump/motor group

The material number of the basic power unit includes:

Reservoir to AB40-40; accessories to AB40-50;
pump/motor group to RE 51062

Pump types:

Axial piston pumps: A10VSO...DFR1/DFLR to RE 92711
Vane pumps: PV7-1X/...C0 to RE 10515

Reservoir size	Frequency		1)	50 Hz 1500 min ⁻¹	60 Hz 1800 min ⁻¹	Electric motor frame size	Basic power unit with pump group -basic variant-	Basic power unit with pump group and start-up circuit	Weight in kg		
	50 Hz 1500 min ⁻¹	60 Hz 1800 min ⁻¹									
	Pump	$q_{v \max}$ l/min	p_{\max} in bar	Power in kW							
100	A10VSO18	26	31	90	4	4.8	112M-4-B0	R901039711	R901038153	135	
				110	5.5	6.6	132S-4-B0	R901039712	R901038463	155	
				138	7.5	9	132M-4-B1	R901039713	R901038464	160	
	V7 10-14	21	24	34	1.5	1.8	90L-4-A1	R901039714		110	
				69	3	3.6	100L-4-A1	R901039715		120	
				91	4	4.8	112M-4-B0	R901039716		130	
				126	5.5	6.6	132S-4-B0	R901039717		145	
	PV7/16-20	29	35	90	5.5	6.6	132S-4-B0	R901039718		150	
	160	A10VSO18	26	31	203	11	13.2	160M-4-B0	R901039719	R901038470	285
		A10VSO28	40	49	95	7.5	9	132M-4-B1	R901039720	R901038472	210
132					11	13.2	160M-4-B0	R901039721	R901038473	285	
180					15	18	160L-4-B1	R901039722	R901038474	320	
PV7/16-20		29	35	90	5.5	6.6	132S-4-B0	R901039723		190	
				125	7.5	9	132M-4-B1	R901039724		195	
PV7/25-30		43	52	61	5.5	6.6	132S-4-B0	R901039725		195	
				84	7.5	9	132M-4-B1	R901039726		205	

¹⁾ Pressure values valid with max. displacement

Selection table: Reservoir sizes for pump/motor group

Reservoir size	Frequency		1)	50 Hz 1500 min ⁻¹	60 Hz 1800 min ⁻¹	Electric motor frame size	Basic power unit with pump group - basic variant -	Basic power unit with pump group and start-up circuit	Weight in kg	
	50 Hz 1500 min ⁻¹	60 Hz 1800 min ⁻¹								
	Pumpe	$q_{v \max}$ l/min	p_{\max} in bar	Power in kW						
250	A1OVSO28	40	49	180	15	18	160L-4-B1	R901039727	R901038482	350
				222	18.5	22.2	180M-4-B0	R901039728	R901038479	370
	A1OVSO45	65	78	60	7.5	9	132M-4-B1	R901039729	R901038480	250
				81	11	13.2	160M-4-B0	R901039730	R901038481	320
				111	15	18	160L-4-B1	R901040214	R901038622	350
				137	18.5	22.2	180M-4-B0	R901039731	R901038483	380
				162	22	26.4	180L-4-B1	R901039732	R901038484	400
	(DFLR-7,5)			-	7.5	9	132M-4-B1	R901046709	R901046710	240
	PV7/25-30	43	52	122	11	13.2	160M-4-B0	R901039734		300
	PV7/40-45	66	78	40	5.5	6.6	132S-4-B0	R901039735		240
				55	7.5	9	132M-4-B1	R901039736		250
				80	11	13.2	160M-4-B0	R901039737		300
				109	15	18	160L-4-B1	R901039745		330
	400	A1OVSO45	65	78	162	22	26.4	180L-4-B1	R901039754	R901038490
222					30	36	200L-4-B0	R901039755	R901038491	590
A1OVSO71		100	124	72	15	18	160L-4-B1	R901039756	R901038492	480
				89	18.5	22.2	180M-4-B0	R901039757	R901038493	530
				106	22	26.4	180L-4-B1	R901039758	R901038494	530
				144	30	36	200L-4-B0	R901039759	R901038495	610
				178	37	44.4	225S-4-B0	R901039760	R901038496	680
(DFLR-11)				-	11	13.2	160M-4-B0	R901046721	R901046724	470
(DFLR-15)				-	15	18	160L-4-B1	R901046725	R901046726	480
PV7/40-45		66	78	134	18.5	22.2	180M-4-B0	R901039761		480
PV7/63-71		108	124	24	5.5	6.6	132S-4-B0	R901039762		350
				33	7.5	9	132M-4-B1	R901039763		360
				49	11	13.2	160M-4-B0	R901039766		420
				67	15	18	160L-4-B1	R901039767		460
	82			18.5	22.2	180M-4-B0	R901039769		490	
	98			22	26.4	180L-4-B1	R901039770		510	

1) Pressure values valid with max. displacement

Selection table: Reservoir sizes for pump/motor group

Reservoir size	Frequency		1)	50 Hz 1500 min ⁻¹	60 Hz 1800 min ⁻¹	Electric motor frame size	Basic power unit with pump group -basic version-	Basic power unit with pump group and start-up circuit	Weight in kg	
	50 Hz 1500 min ⁻¹	60 Hz 1800 min ⁻¹								
	Pump	$q_{v \max}$ l/min	p_{\max} in bar	Leistung in kW						
630	A10VSO71	100	124	178	37	44.4	225S-4-B0	R901039771	R901038504	770
				216	45	54	225M-4-B1	R901039774	R901038505	800
	A10VSO100	145	174	61	18.5	22.2	180M-4-B0	R901039775	R901038506	600
				73	22	26.4	180L-4-B1	R901039776	R901038507	620
				99	30	36	200L-4-B0	R901039777	R901038508	710
				122	37	44.4	225S-4-B0	R901039780	R901038509	800
				149	45	54	225M-4-B1	R901039781	R901038510	840
				182	55	66	250M-4-B0	R901039783	R901038511	960
	(DFLR-18,5)			–	18.5	21.6	180M-4-B0	R901046734	R901046736	600
	(DFLR-22)			–	22	26.4	180L-4-B1	R901046738	R901046739	620
	PV7/63-71	108	124	133	30	36	200L-4-B0	R901038512		670
	PV7/100-118	171	205	31	11	13.2	160M-4-B0	R901039788		540
				42	15	18	160L-4-B1	R901039790		570
				52	18.5	22.2	180M-4-B0	R901039791		620
62				22	26.4	180L-4-B1	R901039796		640	
84				30	36	200L-4-B0	R901039799		700	
126				45	54	225M-4-B1	R901039800		790	
800	A10VSO140	200	244	72	30	36	200L-4-B0	R901039801	R901038519	780
				89	37	44.4	225S-4-B0	R901039802	R901038520	850
				108	45	54	225M-4-B1	R901039803	R901038521	870
				132	55	66	250M-4-B0	R901039804	R901038522	990
				180	75	90	280S-4-B0	R901039805	R901038523	1230

1) Pressure values valid with max. displacement

Circuit diagram of basic power unit ABMAG

Type Basic power unit with	Circuit diagram
<p>pump group A10VSO...DFR1 Basic version</p>	
<p>Pump group A10VSO...DFLR Basic version</p>	

Circuit diagram of basic power unit ABMAG

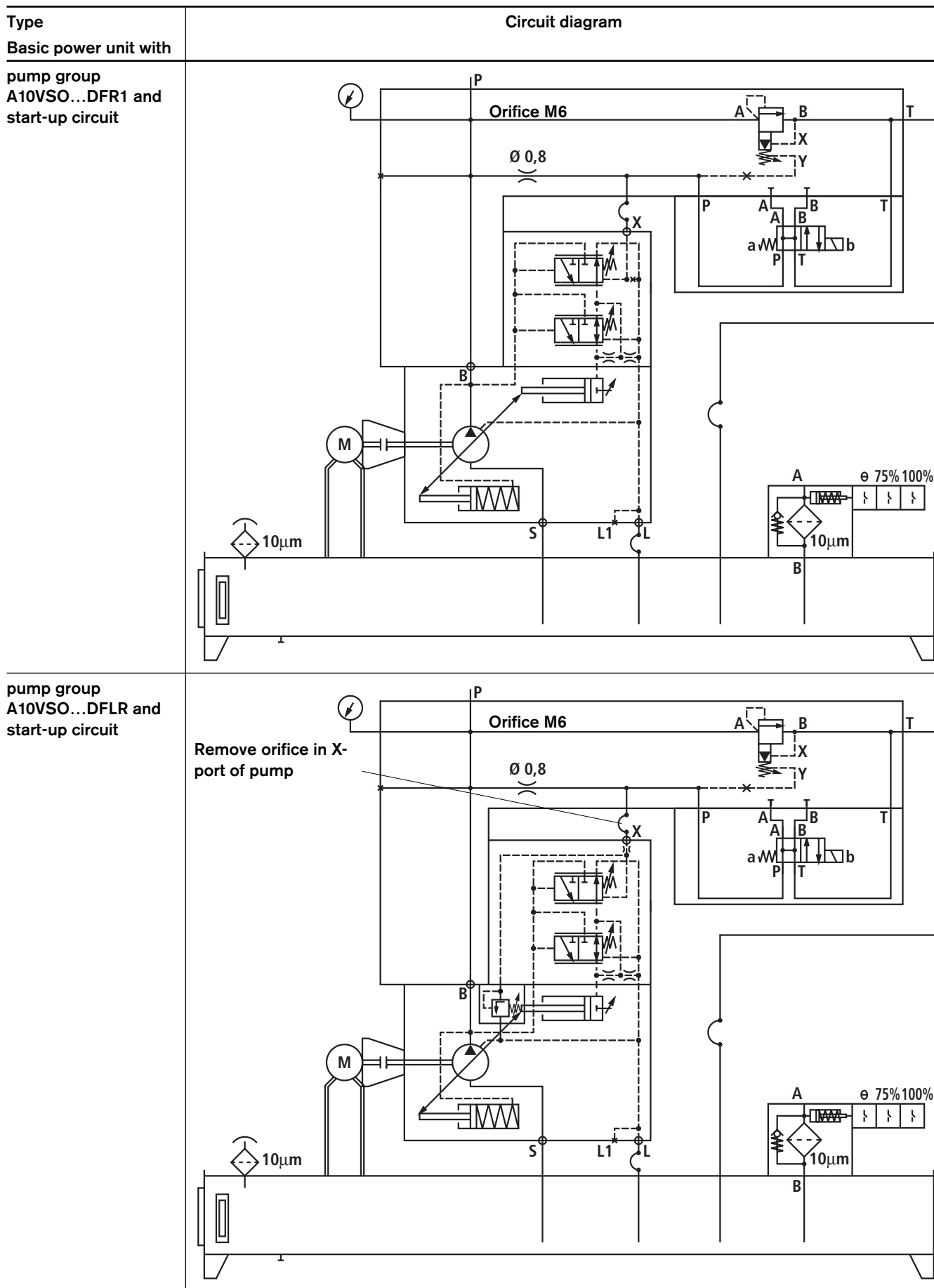

Circuit diagram of basic power unit ABMAG

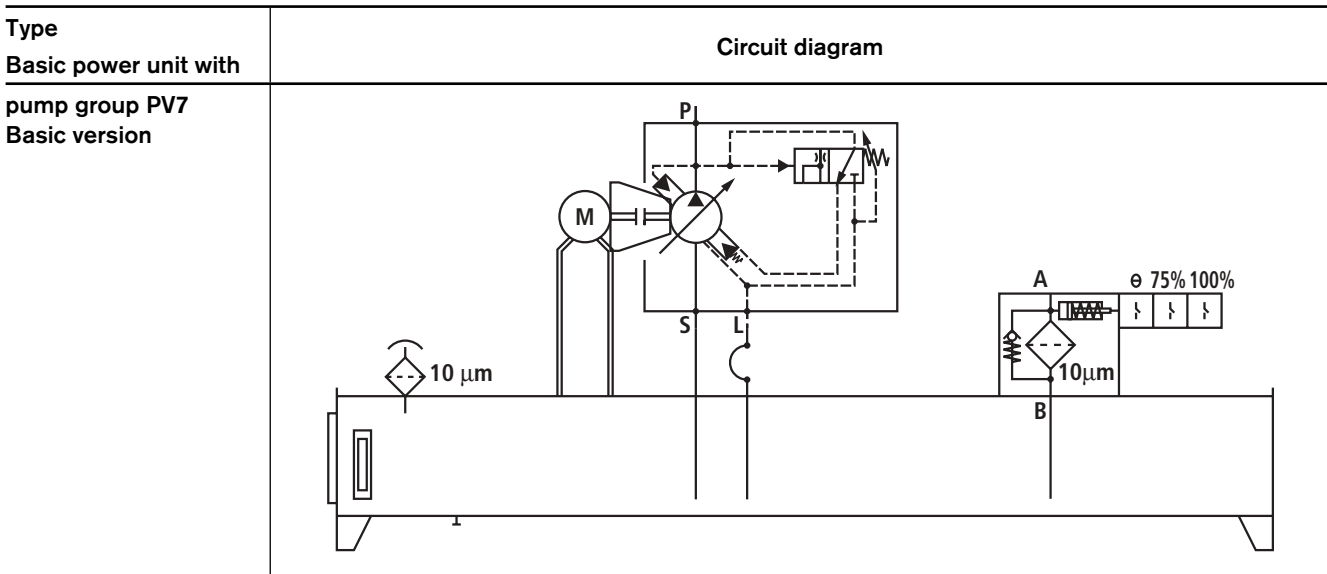

Pipe connections of basic power units

Pump	Port P (pipe Ø or flange/thread)	
	Basic power unit with pump group -basic version-	Basic power unit with pump group and start-up circuit
A1OVSO18	SAE 3/4" (3000 PSI)	20
A1OVSO28	SAE 3/4" (3000 PSI)	20
A1OVSO45	SAE 1" (3000 PSI)	25
A1OVSO71	SAE 1" (3000 PSI)	30
A1OVSO100	SAE 1 1/4" (6000 PSI)	38
A1OVSO140	SAE 1 1/4" (6000 PSI)	38
V7 10-14	G1/2	-
PV7/16-20	G3/4	-
PV7/25-30	G1	-
PV7/40-45	G1	-
PV7/63-71	SAE 1 1/4" (3000 PSI)	-
PV7/100-118	SAE 1 1/4" (3000 PSI)	-

Return line filters for basic power units (included in basic power unit)

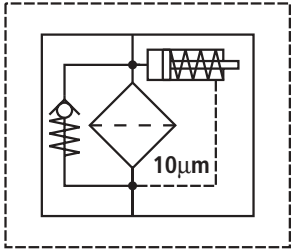
Basic power unit $q_{V \max}$ L/min 50 Hz 1500 min ⁻¹	DIN filter		Filter spare element	Symbol
	Type	Material no.	Material no.	Circuit diagram symbol
< 50	ABZFR-S0100-10-1X/M-DIN	R901025412	R901025278	
≥ 50; < 70	ABZFR-S0160-10-1X/M-DIN	R901025413	R901025279	
≥ 70; < 110	ABZFR-S0250-10-1X/M-DIN	R901025414	R901025283	
≥ 110; < 175	ABZFR-S0400-10-1X/M-DIN	R901025415	R901025286	
≥ 175	ABZFR-S0630-10-1X/M-DIN	R901025416	R901025288	

For supplementary technical details, see
return line filters to DIN 24550 for direct tank top mounting,
type ABZFR...-DIN RE 50088

Filter clogging indicators for return line filters of basic power units (included in basic power)

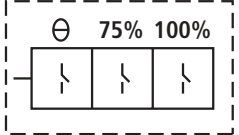
Backpressure indicator	Type	Material no.	Circuit diagram symbol
Electrical – 2 switching points with signal suppression up to 30 °C	ABZFV-E2SPSU -M12X1-1X/M-DIN	R901025341	

For supplementary technical details, see
return line filters to DIN 24550 for direct tank top mounting,
type ABZFR...-DIN RE 50088

Option – float switch

Reservoir size	Float switch length in mm	Float switch AB 31-36 with 2 switching contacts (adjustable) M12 connection
100 160 250 400 630 800	370	R901066117

For supplementary technical data, see AB standard - AB31-36

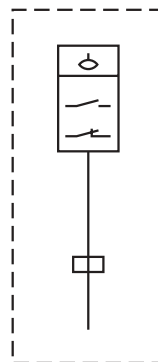

Option – thermostat

Type	Material no.	Plug
THERMOSTAT AB31-14/3-1A2A-TA-M12	R901018305	M12
THERMOSTAT AB31-14/3-1A2A-TA	R900013646	None

For supplementary technical data, see AB standard - AB31-14

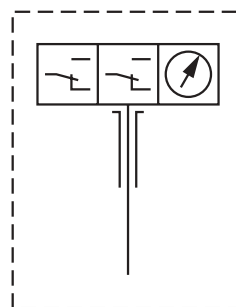

Option – heater

Reser-voir size	Heater – power code / power in Watt	Material no.	Max. qty.
100	4 / 370	R900024795	1
160	5 / 740	R900024796	
250	6 / 1080	R900024797	
400			2
630			
800			

For supplementary technical data, see AB standard - AB32-10

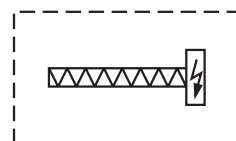

Option – filter/cooler circulation circuit (water)

Power of basic power unit in kW 50 Hz 1500 min ⁻¹	Thermal output in kW	$q_{V \max}$ in L/min at 1500 min ⁻¹	Power in kW at 1500 min ⁻¹	El. motor frame size	In-line filter size	Filter clogging indicator	Cooler type AB 32-12/	Material no. of assembly	Material no. of filter spare element
≤ 22	4	19	0.75	80	63	ABZFV-E2SPSU-M12X1-1X/-DIN	00-K-006	R901061642	R901025361
	7	26	1.1	90S	100		00-K-010	R901061643	R901025362
> 22; ≤ 55	15	67	2.2	100L	160		00-K-026	R901061644	R901025363
	22	67					00-K-034	R901061645	
> 55; ≤ 75	30	83	3				00-L-038	R901061646	

For supplementary technical data, see filter/cooler circulation circuit to RE 50126

Circuit diagram symbol

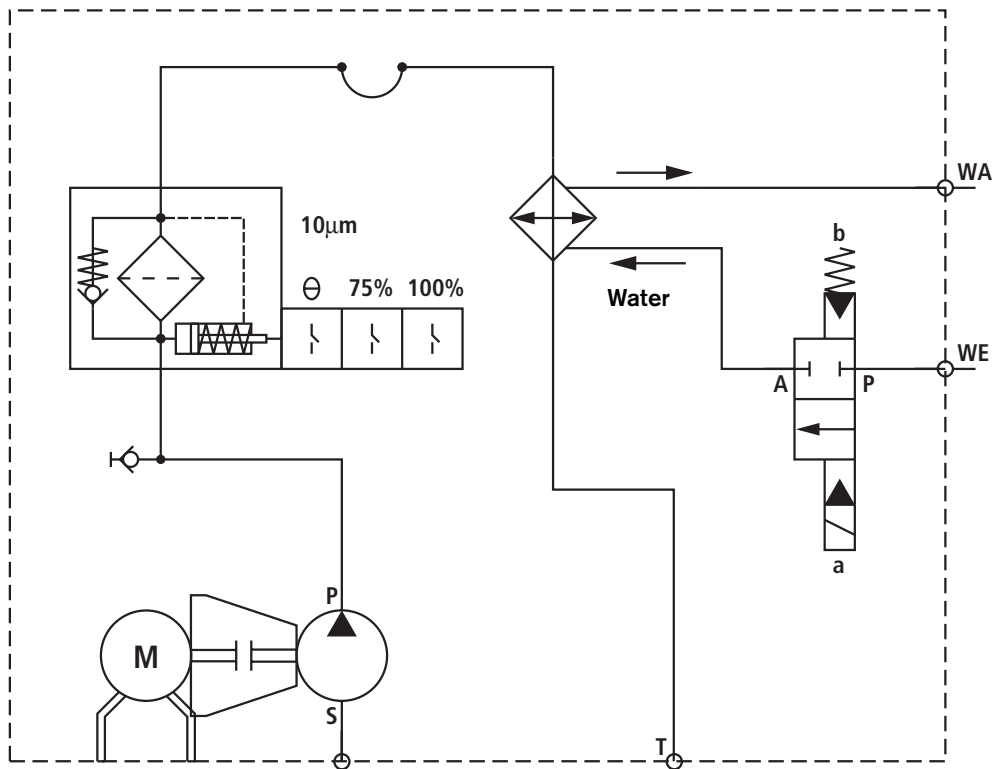

Option – filter/cooler circulation circuit (air cooling capacity 4 / 6 kW) (nominal dimensions in mm)

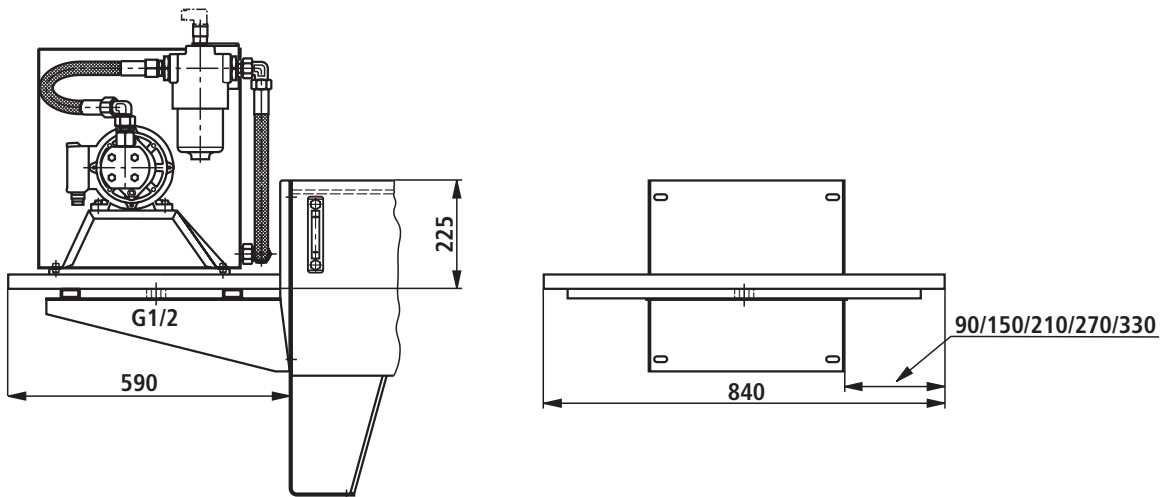

Reser- voir size in L	Thermal output in kW	$q_{v \max}$ in L/min at 1500 min ⁻¹	Power in kW at 1500 min ⁻¹	El. mo- tor frame size	In-line filter size	Filter clog- ging indicator	Cooler type KOLP...F...	Material no. of assembly	Material no. of filter spare ele- ment
100- 800	4	20	1.1	90S	160	ABZFV- E2SPSU- M12X1-1X/ -DIN	KOLP8N-1X/R- 30F160-10-E/M	R904102059	R901025363
	6	45	1.5	90L			KOLP10N-1X/R- 45F160-10-E/M	R904102063	

Für supplementary technical data, see
oil/air cooler types KOL and KOLP to RE 50111
Selection at $\Delta t = 25 \text{ }^\circ\text{C}$

Required accessories (to be ordered separately)		
Material no.	Type	Weight in kg
R901021254	KONSOLE KOLP3-10/ABMAG-2X	27

Circuit diagram symbol

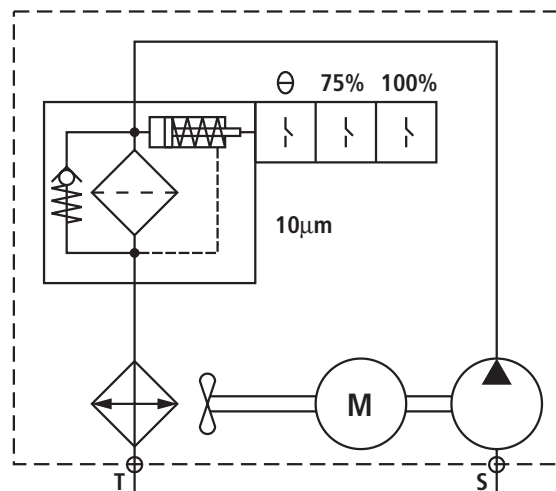

Option – filter/cooler circulation circuit (air cooling capacity 16 / 25 kW) (nominal dimensions in mm)

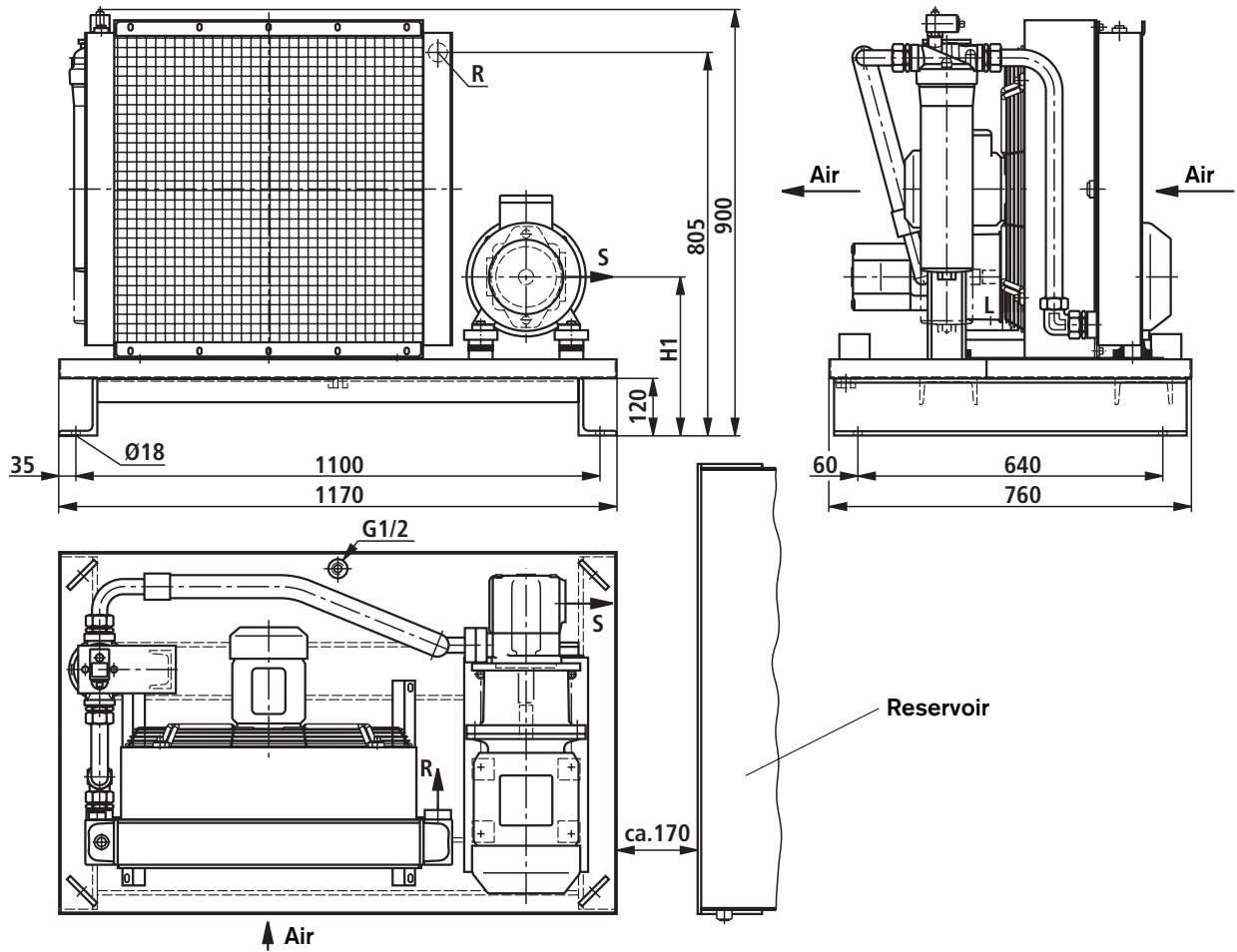

Material no. of assembly	Type	H1	S	R	Weight in kg
R901075864	ABUKG-16L / 30N/46/100L4A0/160	341	SAE 11/2UNC	G1 1/4	220
R901075866	ABUKG-25L / 40N/98/112M4B0/400	333	SAE 2-UNC		245

Reser- voir size in L	Thermal output in kW	Pump/ motor group ABUPG $q_{V \max}$	Power in kW at 1500 min^{-1}	In-line filter - DIN - size	Filter clogging indicator	Cooler type	Material no. of assembly	Material no. of filter spa- re element
400/630/ 800	16	63	2,2	160	ABZFV- E2SPSU- M12X1-1X/- DIN	KOL30N-1X/A/M	R901075864	R901025363
630/800	25	135	4	400		KOL40N-1X/A/M	R901075866	R901025365

Selection at $\Delta t = 25 \text{ }^\circ\text{C}$

Circuit diagram symbol

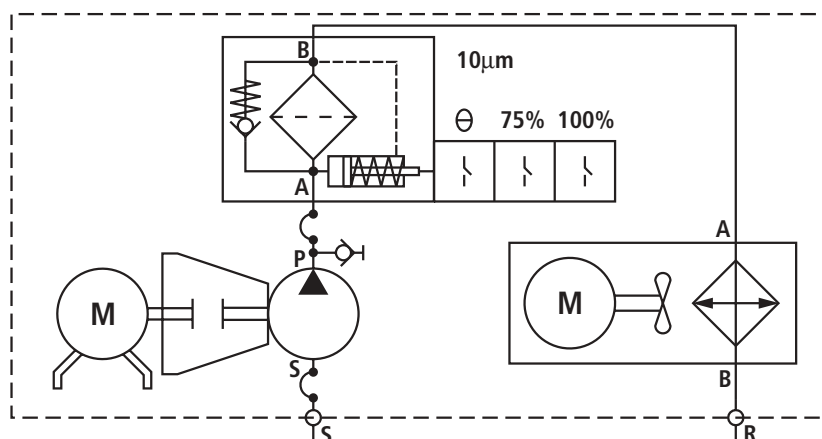

The suction hose is included in the scope of supply of the assembly.

Option – accumulator station

with manually operated drain valve

Accumulator type	Accumulator size in litres	Relief pressure PN in bar	Safety block DN	Designation	Material no.	Reservoir size
Bladder-type accumulator	1.0	330	10	ABSBG-B1,0/SS10-U-330-M CM/C	R900713406	≥ 100
	2.5	330	10	ABSBG-B2,5/SS10-U-330-M CM/C	R900713407	
	4.0	330	10	ABSBG-B4,0/SS10-U-330-M CM/C	R900713408	
	10 ¹⁾	330	20	ABSBG-B10/SS20-U-330-M CM/C	R900713409	
	20 ¹⁾	330	20	ABSBG-B20/SS20-U-330-M CM/C	R900713410	≥ 160
	32 ¹⁾	330	30	ABSBG-B32/SS30-U-330-M CM/C	R9007 13411	≥ 400
	50 ¹⁾	330	30	ABSBG-B50/SS30-U-330-M CM/C	R900713412	
Dia-phragm-type accumulator	0.6	330	10	ABSBG-M0,6/SS10-U-330-M CM/C	R900713413	≥ 100
	0.75	210	10	ABSBG-M0,75/SS10-U-210-M CM/C	R900713414	
	1.4	140	10	ABSBG-M1,4/SS10-U-140-M CM/C	R900713415	
	2.0	100	10	ABSBG-M2,0/SS10-U-100-M CM/C	R900713416	

For supplementary technical data, see accumulator stations to RE 50135

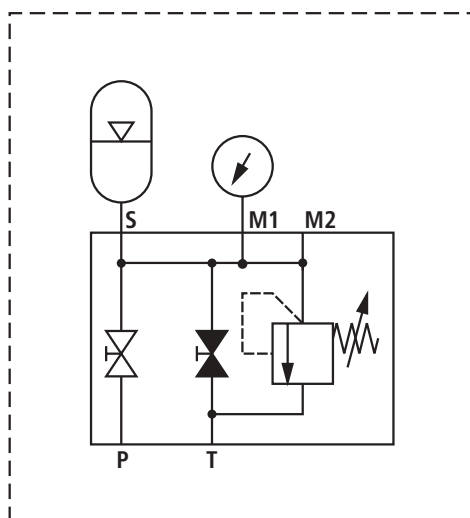

¹⁾ Required accessories must be ordered separately

Material number	Designation	Qty
R901024051	LEISTE AB-ABSBG10-50/2X11,0 /ABMAG-2X	1
R901024057	LEISTE AB-ABSBG10-50/4XM10 /ABMAG-2X	1

Option – accumulator station

with electrically operated drain valve

Accumulator type	Accumulator size in litres	Relief pressure PN in bar	Safety block DN	Designation	Material no.	Reservoir size
Bladder-type accumulator	1.0	330	10	ABSBG-B1,0/SS10-U-330-EG24NK4CM/C	R900713425	≥ 100
	2.5	330	10	ABSBG-B2,5/SS10-U-330-EG24NK4CM/C	R900713426	
	4.0	330	10	ABSBG-B4,0/SS10-U-330-EG24NK4CM/C	R900713427	
	10 ¹⁾	330	20	ABSBG-B10/SS20-U-330-EG24NK4CM/C	R900713428	≥ 160
	20 ¹⁾	330	20	ABSBG-B20/SS20-U-330-EG24NK4CM/C	R900713429	
	32 ¹⁾	330	30	ABSBG-B32/SS30-U-330-EG24NK4CM/C	R900713431	
	50 ¹⁾	330	30	ABSBG-B50/SS30-U-330-EG24NK4CM/C	R900713432	
Diaphragm-type accumulator	0.6	330	10	ABSBG-M0,6/SS10-U-330-EG24NK4CM/C	R900713433	≥ 100
	0.75	210	10	ABSBG-M0,75/SS10-U-210-EG24NK4CM/C	R900713434	
	1.4	140	10	ABSBG-M1,4/SS10-U-140-EG24NK4CM/C	R900713435	
	2.0	100	10	ABSBG-M2,0/SS10-U-100-EG24NK4CM/C	R900713436	

For supplementary technical data, see accumulator assemblies to RE 50135

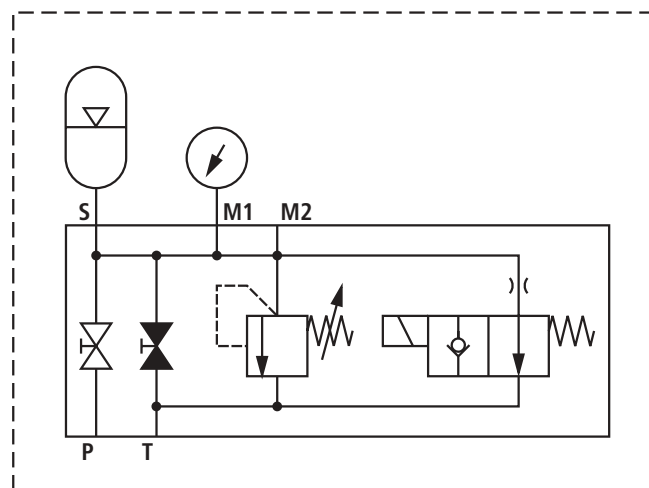

¹⁾ Required accessories must be ordered separately

Material number	Designation	Quantity	Weight in kg
R901024051	LEISTE AB-ABSBG10-50/2X11,0 /ABMAG-2X	1	0.9
R901024057	LEISTE AB-ABSBG10-50/4XM10 /ABMAG-2X	1	2.1

Option – pump safety block with pressure filter (DIN filter) for A10VSO pump

Item	Designation	Designation	Material number	Material number of pump safety block (complete, items 1-6) for pump					
				A10VSO 18/28 R901083658	A10VSO 45 R901087400	A10VSO 71 R901087402	A10VSO 100 R901087403	A10VSO 140 R901087405	
1	Pressure filter 70 L/min ¹⁾	ABZFD-L0063-10H-315-1X/M-DIN	R901090669	<input type="checkbox"/>	-	-	-	-	
	Pressure filter 160 L/min ¹⁾	ABZFD-L0160-10H-315-1X/M-DIN	R901062381	-	<input type="checkbox"/>	<input type="checkbox"/>	-	-	
	Pressure filter 280 L/min ¹⁾	ABZFD-L0250-10H-315-1X/M-DIN	R901067699	-	-	-	<input type="checkbox"/>	<input type="checkbox"/>	
2	Directional valve	4WE 6 HB6X/...	...	<input type="checkbox"/>	<input type="checkbox"/>	<input type="checkbox"/>	<input type="checkbox"/>	<input type="checkbox"/>	
3	Pressure relief valve	DB 20 K2-1X/315XY	R900493939	<input type="checkbox"/>	<input type="checkbox"/>	<input type="checkbox"/>	<input type="checkbox"/>	<input type="checkbox"/>	
4	Pressure gauge	Manometer AB31-11/063-400	R900002686	<input type="checkbox"/>	<input type="checkbox"/>	<input type="checkbox"/>	<input type="checkbox"/>	<input type="checkbox"/>	
5	Pressure switch	HED 8 OH1X/350K14	R900536049	<input type="checkbox"/>	<input type="checkbox"/>	<input type="checkbox"/>	<input type="checkbox"/>	<input type="checkbox"/>	
6	Clogging indicator (electrical)	ABZFV-E2SPSU-M12X1-1X/-DIN	R901025341	<input type="checkbox"/>	<input type="checkbox"/>	<input type="checkbox"/>	<input type="checkbox"/>	<input type="checkbox"/>	
	Port P (for pipe)			20	25	30	38	38	
	Filter spare element	Material number		R901025384	R901025386	R901025386	R901025387	R901025387	
		Designation		ABZFE-H0063-10-1X/M-DIN	ABZFE-H0160-10-1X/M-DIN	ABZFE-H0160-10-1X/M-DIN	ABZFE-H0250-10-1X/M-DIN	ABZFE-H0250-10-1X/M-DIN	

These components are included in the material number of the pump safety block

¹⁾ Flow in litres/min at $\Delta p = 1$ bar (values measured at 33 mm²/s)

For supplementary technical data, see AB 51-01-002

Note:

The pump safety block cannot be mounted onto reservoir size 100.

Option – pump safety block with pressure filter (DIN filter) for A10VSO pump

Maximum pressure relief function and start-up at zero pressure

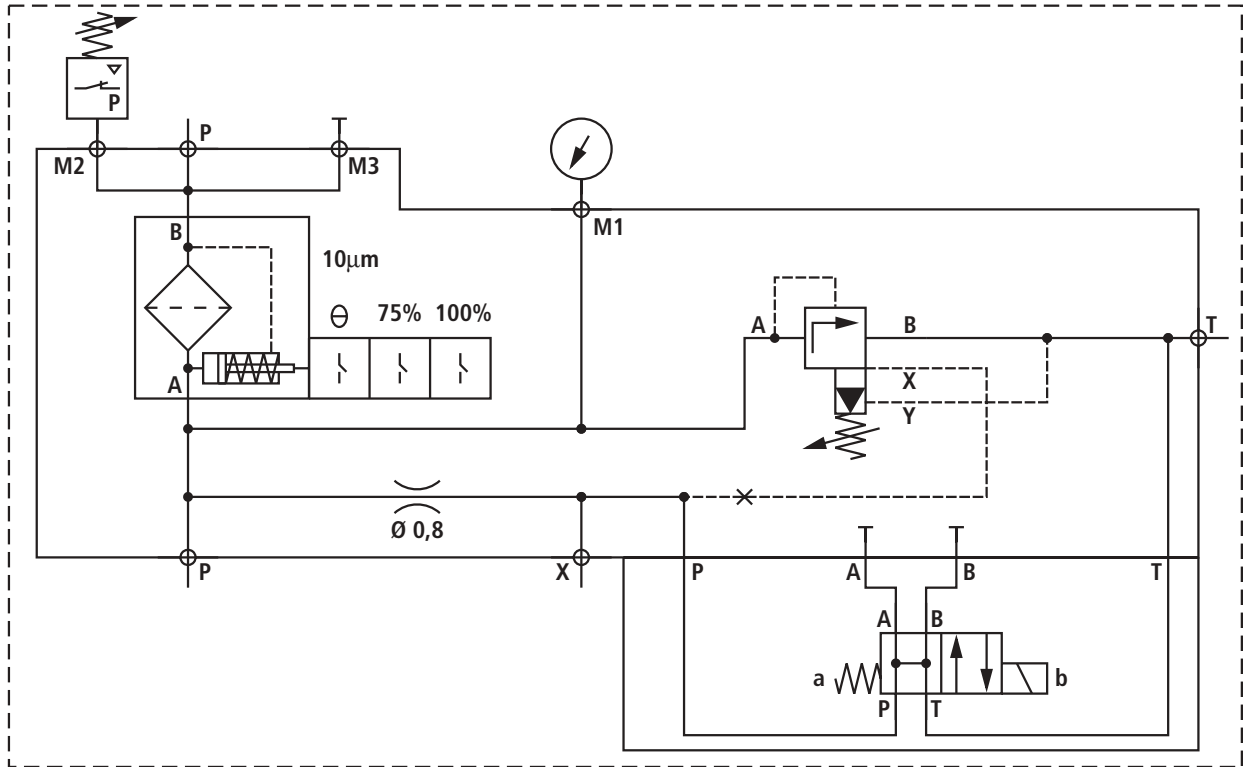

Option – pump safety block with pressure filter type PSBD

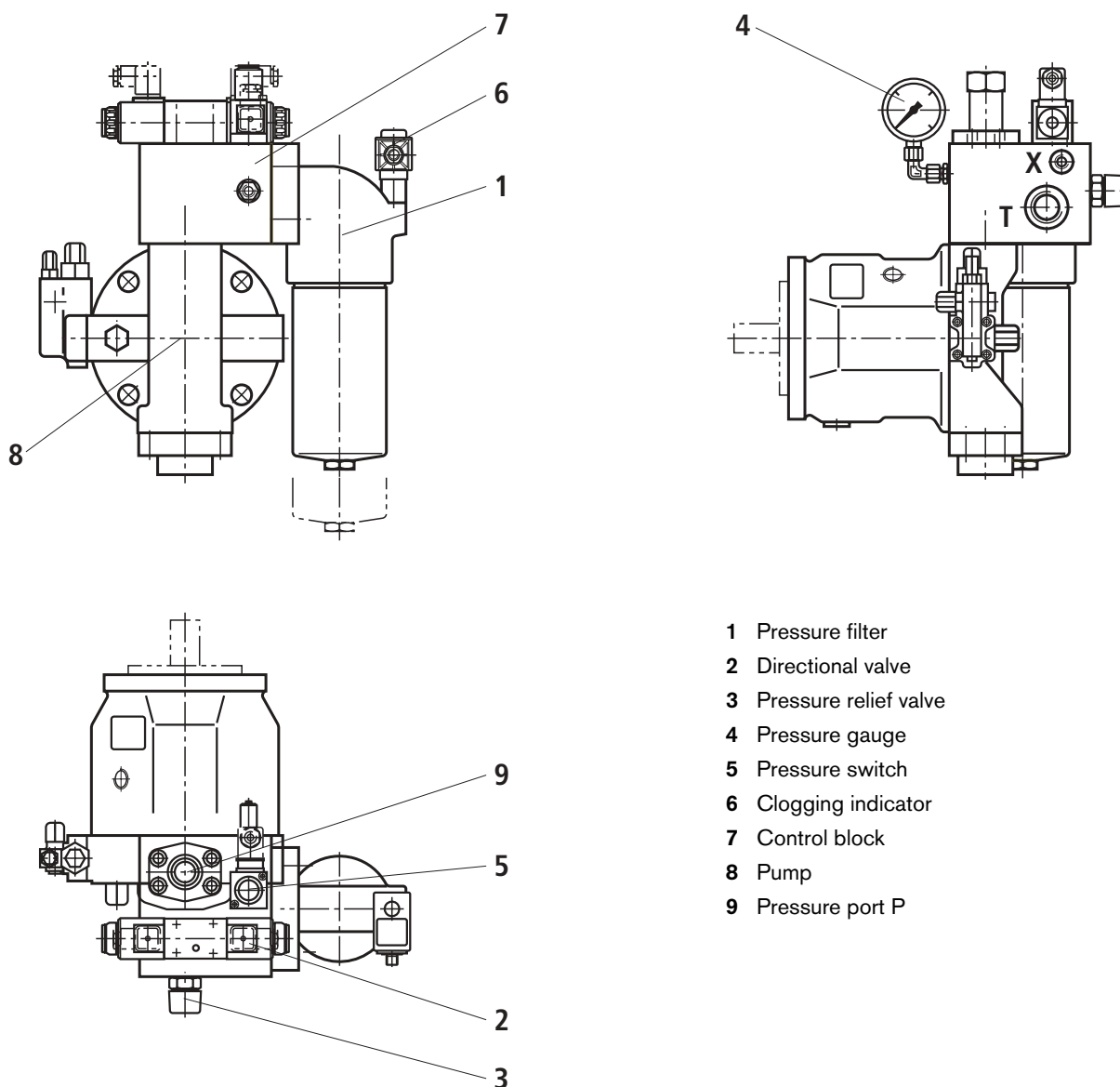

Pump type	Pump safety block with pressure filter (complete)	
	Designation	Material number
A10VSO 18/28	PSBD01H28-1X/S315-R10R1W-24/31M	R901083658
A10VSO 45	PSBD01H45-1X/S315-R10R1W-24/31M	R901087400
A10VSO 71	PSBD01H71-1X/S315-R10R1W-24/31M	R901087402
A10VSO 100	PSBD01H100-1X/S315-R10R1W-24/31M	R901087403
A10VSO 140	PSBD01H140-1X/S315-R10R1W-24/31M	R901087405

Option – oil drip tray according to the Water Resources Act (nominal dimensions in mm)

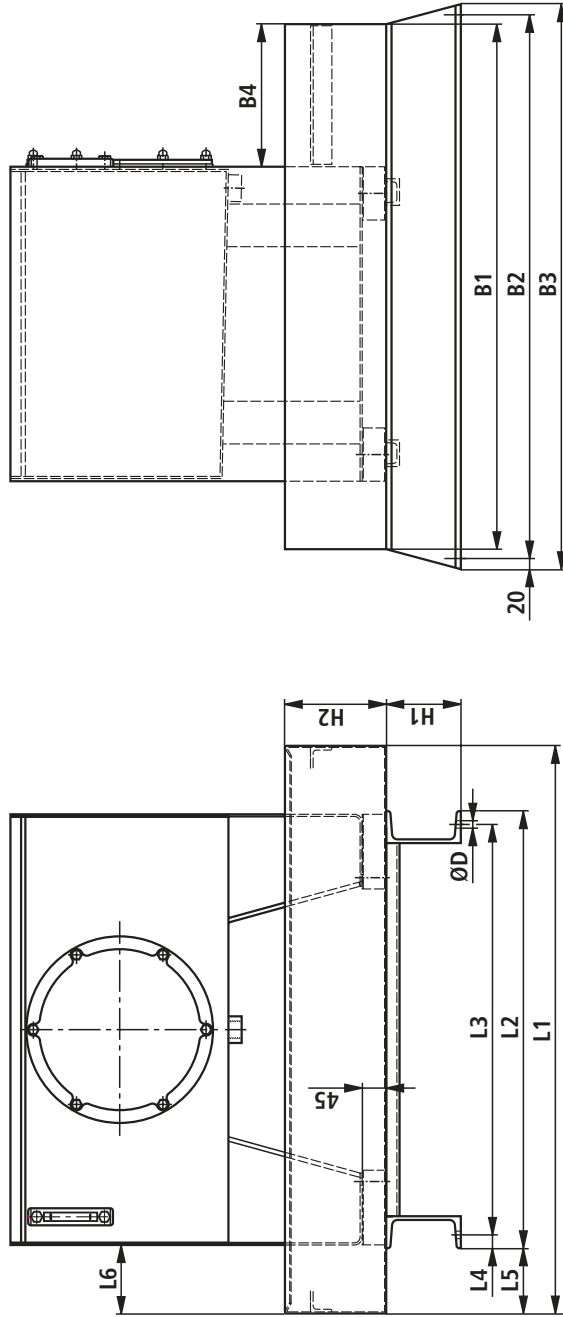

Oil drip tray made of steel (standard)

Dimensions to AB 40-40

Size of the reservoir in litres	Collection capacity of oil drip tray in litres	L1	L2	L3	L4	L5	L6	D	H1	H2	B1	B2	B3	B4	Material no.	Weight in kg
100	125	890	645	595	25	122	128	14	140	190	855	890	930	267	R900225020	55
160	175	1065	820	770	25	122	128	14	140	190	985	1020	1060	267	R900225021	67
250	280	1265	1010	960	25	127	128	14	140	230	1085	1130	1170	267	R900225022	94
400	445	1790	1460	1410	25	165	139	14	140	240	1150	1180	1230	277	R900225023	129
630	700	2070	1460	1410	25	305	279	14	140	250	1500	1530	1580	277	R900225024	204
800	900	2590	1970	1910	30	310	289	18	160	260	1475	1480	1530	2870	R900225026	245

Oil drip tray made of steel with enlarged surface for use with lateral attachments (ABUKG; KOLP; ABSBG with baldder-type accumulators of 10 L or greater)

Size of the reservoir in litres	Collection capacity of oil drip tray in litres	L1	L2	L3	L4	L5	L6	D	H1	H2	B1	B2	B3	B4	Material no.	Weight in kg
100	125	1310	645	595	25	342,5	348	14	140	150	855	890	930	267	R901040026	98
160	175	1485	820	770	25	342,5	348	14	140	150	985	1020	1060	267	R901036361	114
250	280	1685	1010	960	25	347,5	348	14	140	180	1085	1130	1170	267	R901068964	133
400	445	2265	1460	1410	25	440	414	14	140	200	1150	1180	1230	277	R901069970	186
630	700	2250	1460	1410	25	425	399	14	140	230	1500	1530	1580	277	R901071210	287
800	900	2770	1970	1910	30	430	409	18	160	240	1475	1480	1530	287	R901071655	337

Option – control assembly IH20

The advantages of the modular plate systems:

- Free configuration of different circuits
- High variability due to consequent segmentation
- Valve sizes from size 6 to 25 can be combined
- Complex circuits can be integrated
- Reduced piping effort and therefore reduced number of sealing points

Nominal pressures:

Port	P	320 bar
Port	T	100 bar
Outlets	A, B	320 bar

Circuit example

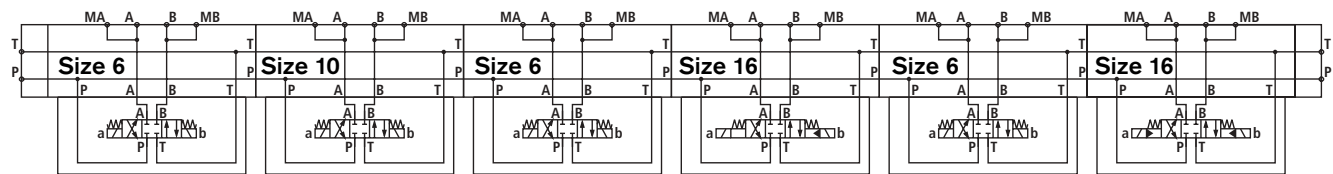

Set-up variant

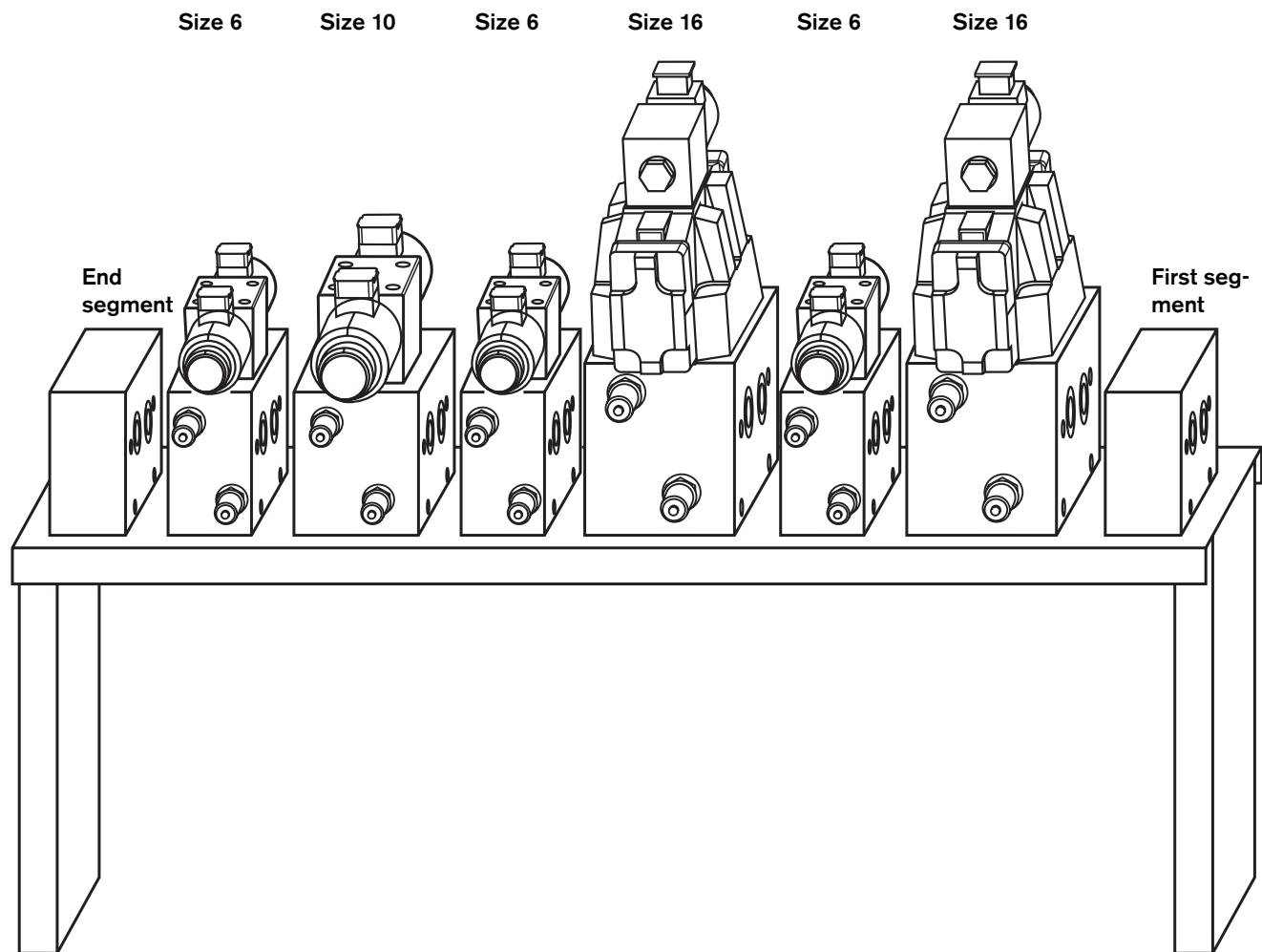

Option – control assembly (nominal dimensions in mm)

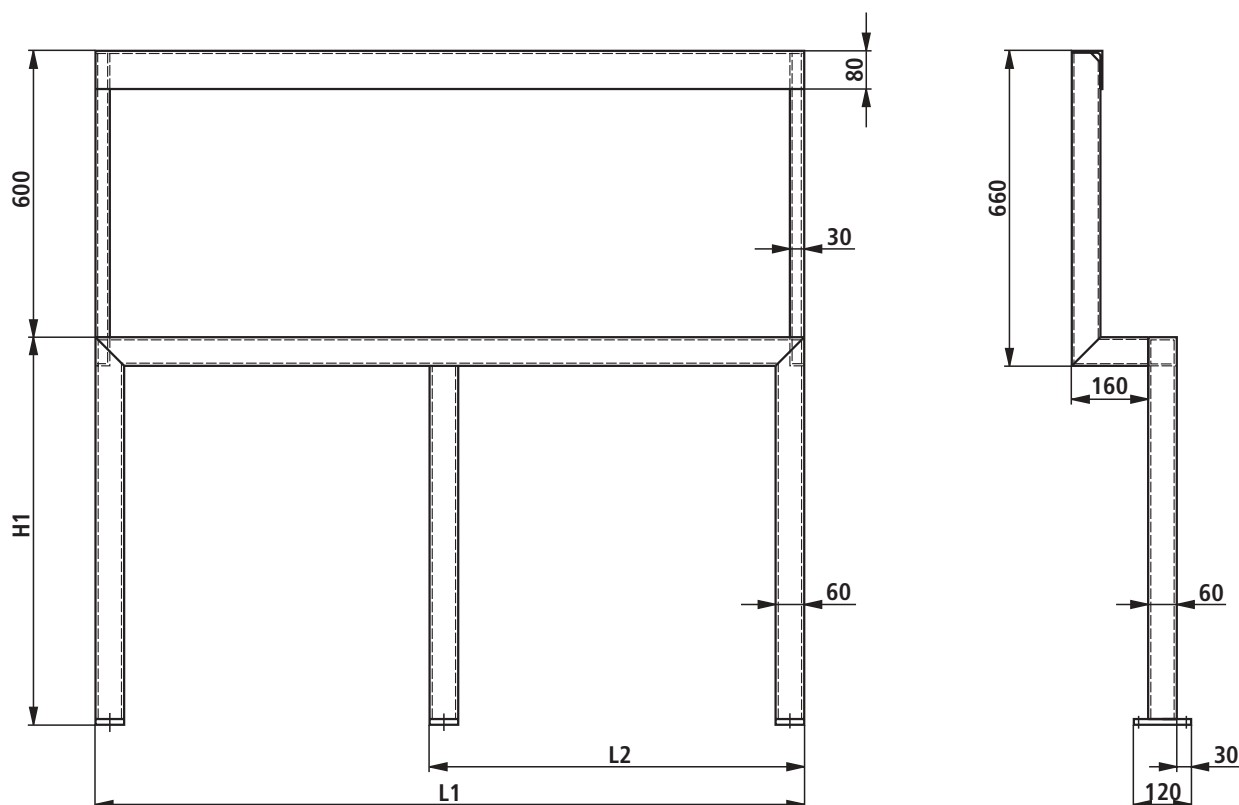

Reservoir size	Console material no.	L1	L2	H1	Remarks	Max. stacking length of modular plate system	Weight in kg
100	R901040017	610	–	512	–	L1-200 mm	17
160/400/630/800	R901036309	785	–	512	up to motor frame size 180		24
250	R901067224	985	–	512	–		26
400/630/800	R901074997	785	–	812	from motor frame size 200		28
400/630/800	R901094429	1485	785	512	up to motor frame size 180		37
400/630/800	R901070073	1485	785	812	from motor frame size 200		41

Note:

The console for setting up a modular plate system must be ordered separately.

Standard controls, frame size A $q_{max} < 40$ L/min

	Type	Material no. for segment without valves	Circuit diagram symbol
End segment	IH20M1A-ES 02-10/M01	R900780029	
Valve segment size 6	IH20M2A-VS 006A 01-10/M01	R900977155	
Valve segment size 10	IH20M2A-VS 010A 01-10/M01	R900773110	
Valve segment for check valve in P and / or T Check valve insert RKVC-16-0.2 bar Material no. R900031396 Valve can be turned → symbol mirrored	IH20M4A-PT 016X 01-10/M01	R901017780	
Accumulator segment as accumulator safety circuit e.g. for: FL-KHP-10-... R900026848 (NBR) Shut-off valve R900210324 (NBR) KSDER1PA/... R900993076 (FKM) Plug R900617084 (FKM) DBD...10K1X/...	IH20M4A-SP 010R 01-10/M01	R900781825	

Standard controls, frame size A $q_{max} < 40$ L/min

	Type	Material no. for segment without valves	Circuit diagram symbol
<p>Valve segment for pressure limitation</p> <p>For DBD...10K1X/.</p>	IH20M4A-VP 010R 01-10/M01	R900781110	

For supplementary technical data, see AB standard - AB 52-00

Standard controls, frame size B $q_{max} 40 - 200$ L/min

	Type	Material no. for segment without valves	Circuit diagram symbol
End segment	IH20M1B-ES 01-10/M01	R900977160	
Valve segment size 6	IH20M2B-VS 006A 01-10/M01	R900977156	
Valve segment size 10	IH20M2B-VS 010A 01-10/M01	R900977157	

Standard controls, frame size B q_{\max} 40 – 200 L/min

	Type	Material no. for segment without valves	Circuit diagram symbol
Valve segment size 16	IH20M2B-VS 016A 01-10/M01	R900977158	
Distributor segment for two ports each P (G1 1/4) and T (G1 1/2)	IH20M4B-PT 01-10/M01	R900720735	
Valve segment for ports and check valve	IH20M4B-VP 025R 02-10/M01	R901059232	
Pressure filter segment e.g. for: M-SR 25 KE...1X/ Filter e.g.: DF BH/HC 240/256 QE.../-OAI 240: R900990231 (NBR) 256: R900989248 (NBR)	IH20M4B-DF 200 01-10/M01	R900760983	
Valve segment for check valve in P e.g. for: Check valve insert RKVC-32-0,2 bar Material no. R900015439 Valve can be turned → symbol mirrored	IH20M4B-VP 032X 01-10/M01	R900709727	

Standard controls, frame size B q_{\max} 40 – 200 L/min

	Type	Material no. for segment without valves	Circuit diagram symbol
Valve segment for check valve in T e.g. for: Check valve insert RKVC-40-0,2 bar Material no. R900734700 Valve can be turned → symbol mirrored	IH20M4B-VT 040X 01-10/M01	R900734205	
Valve segment with porting pattern type 20 D at port, e.g. for: DR20...5X/...to RE 26892 DZ20...5X/...to RE 26391 SV/SL20...4X/...to RE 21468 FD25...2X/...to RE 27551	IH20M4B-VP 020D 02-10/M01	R900720736	
Valve segment for pressure limitation for: DBD...20K1X/... to RE 25402	IH20M4B-VP 020R 03-10/M01	R901059228	
First segment	IH20M1B-AS 01-10/M01	R900977159	

For supplementary technical data, see AB standard - AB52-00

Typical noise values (measured at 1450 min⁻¹)

Pump type	Size	Pressure in bar							
		100		150		200		280	
		q_{min}	q_{max}	q_{min}	q_{max}	q_{min}	q_{max}	q_{min}	q_{max}
A10VSO	18	71	73	72	74	73	75	74	76
	28	73	75	74	76	75	77	76	78
	45	74	76	75	77	76	78	77	79
	71	76	78	77	79	78	80	80	82
	100	78	80	79	81	80	82	81	83
	140	80	82	81	83	82	84	83	85
V7	10-14	65	67	67	69				
	16-20	67	69	69	71				
	25-30	71	73	73	75				
	40-45	74	76	76	78				
	63-71	77	79	79	81				
	100-118	80	82	82	84				

Sound pressure level according to DIN 45635 part 1, 41;
 measuring distance between microphone and power unit 1 m;
 operating temperature $\vartheta = 50\text{ °C}$;
 hydraulic fluid: Mineral oil HLP to DIN 51524 part 2;

Sound reflections at the place of installation can result in an increased sound pressure level.

Unit dimensions (nominal dimensions in mm)

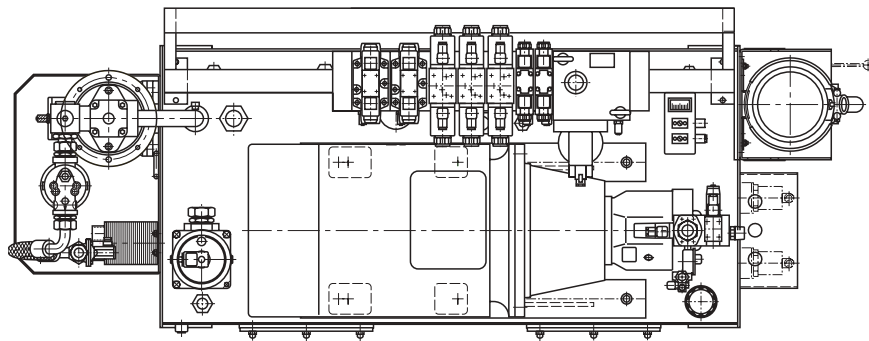
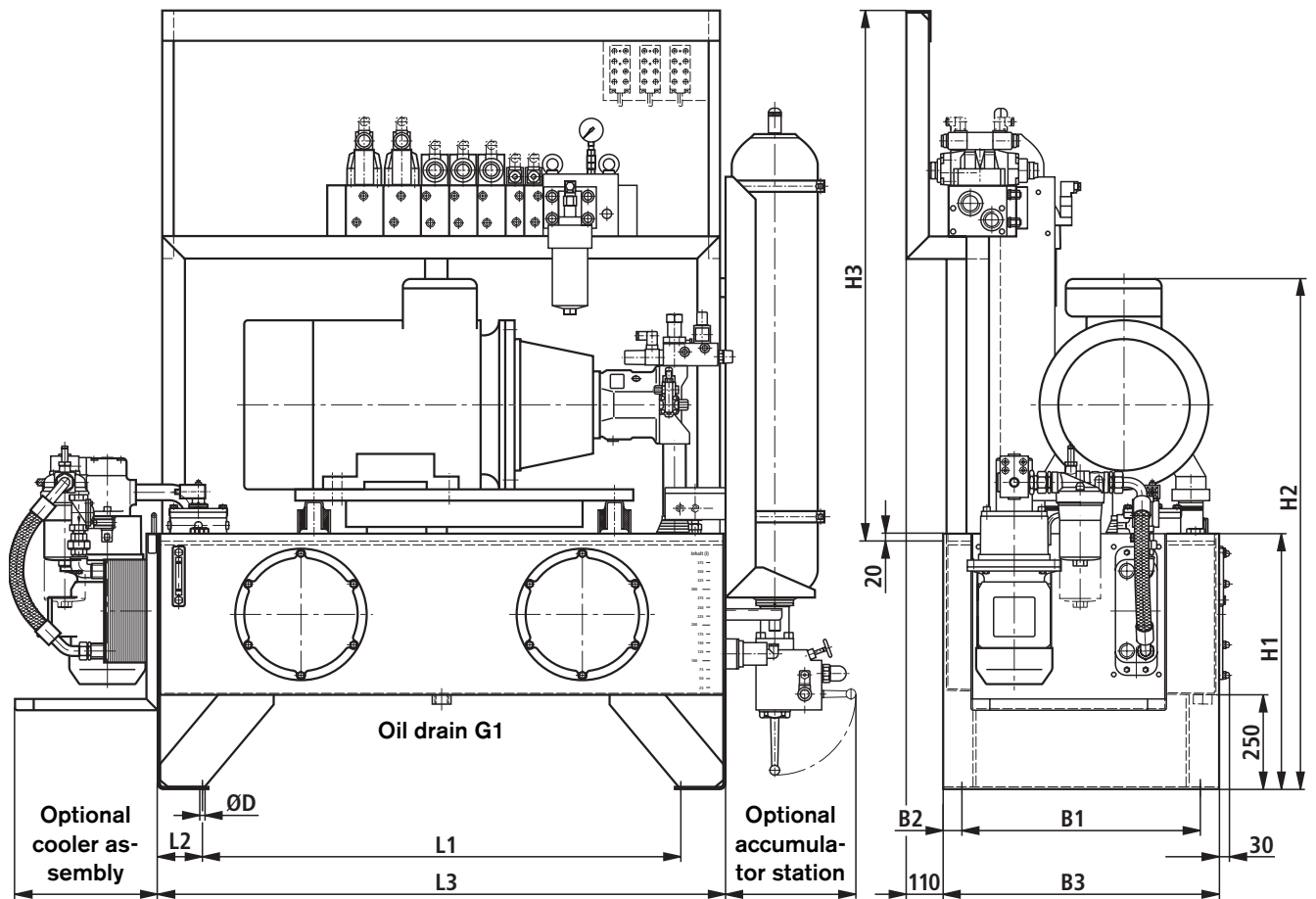

Reservoir size	L1	L2	L3	B1	B2	B3	H1	H2 max	H3	Ø D
100	393	120	633	360	50	460	660	1050	see console	14
160	570	119	808	490		590	660	1180		
250	770		1008	590		690	680	1240		
400	1274		1512	635		735	680	1380		
630	1274		1512	845		945	770	1570		
800	1774		2012	800		900	770	1620		

Engineering notes

The units are assembled according to the modular principle. For further information, please contact your Bosch Rexroth sales agent.

Comprehensive notes and suggestions can be found in The

Hydraulic Trainer, volume 3, RE 00281, "Notes on the planning and design of hydraulic systems."

Commissioning notes

General

- The power units supplied by us have been tested for function and performance. Modifications of whatever nature are not permitted, since this would result in the invalidation of warranty claims.
- Repairs may only be carried out by the manufacturer or his authorised dealers and agencies. Repairs carried out by the customer are not covered by a warranty.

Commissioning

- Only fill hydraulic fluid in through a filter with the required minimum retention rate.
- Observe the arrow for the direction of rotation when connecting the electric motor.
- Start the pump up under no load conditions and allow it run at zero pressure for some seconds in order to provide sufficient lubrication.
- In no case may the pump be operated **without** oil.
- Should the pump not displace bubble-free oil after approx. 20 seconds, re-check the system.
- When the system has reached its operating values, check the pipe connections for leaks. Check the operating temperature.
- **Observe AB 01-01.02 "Operating instructions for hydraulic systems" for commissioning!**

Bleeding

- Before initial commissioning, the pump housing must be filled with oil.

Important notes

- The power units may only be installed, serviced and repaired by authorised, trained and instructed personnel!
- The power units may only be operated within the permitted limits!
- When carrying out any work on the power unit, depressurise the system!
Unauthorised conversions or modifications that affect safety and function are not permitted!
- Fit protective equipment or do **not** remove any existing protective equipment.
- Make sure that all fixing screws are always properly tightened! (Observe prescribed tightening torque!)
- Observe generally valid safety regulations and regulations for the prevention of accidents!
- In the case of reservoir size 100, fill in at least 130 litres (level indicator "max").

Note in the sense of EC Machinery Directive EC-98/37 EEC Annex II Section B; manufacturer's declaration:

The supplied assemblies were manufactured in accordance with the harmonised standards EN 982, EN 983, DIN EN ISO 12100 and DIN EN 60204-1.

Their commissioning is prohibited until it was confirmed that the machine, into which the assemblies are to be integrated, complies with the regulations laid down in the EC Directives

Bosch Rexroth AG
Hydraulics
Zum Eisengießer 1
97816 Lohr am Main, Germany
Phone +49 (0) 93 52 / 18-0
Fax +49 (0) 93 52 / 18-23 58
documentation@boschrexroth.de
www.boschrexroth.de

© This document, as well as the data, specifications and other information set forth in it, are the exclusive property of Bosch Rexroth AG. It may not be reproduced or given to third parties without its consent.

The data specified above only serve to describe the product. No statements concerning a certain condition or suitability for a certain application can be derived from our information. The information given does not release the user from the obligation of own judgment and verification. It must be remembered that our products are subject to a natural process of wear and aging.