

Model Number

CPZ18B03

Mounting Bracket with swivel nut

For Series CP18 Threaded Photoelectric Sensors

Dimensions

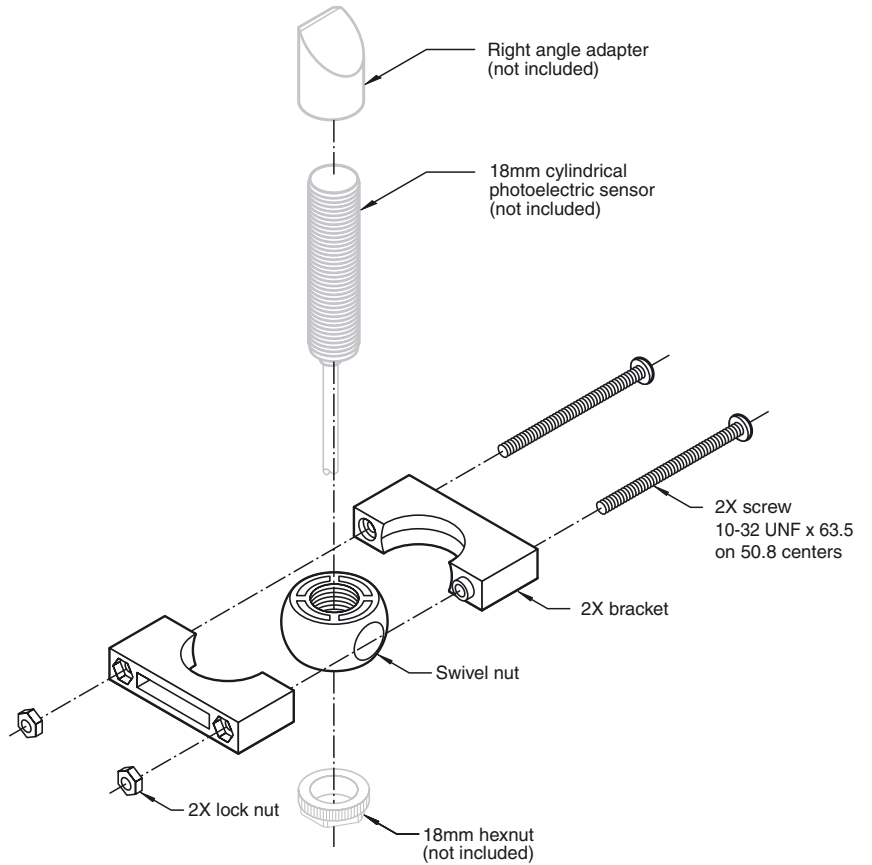

Technical data

Mechanical specifications

Material	plastic
Mass	approx. 85 g
Mounting	Mounting accessories included

Suitable series

Series	CP18
--------	------

Release date: 2012-03-27 16:31 Date of issue: 2012-03-27 453244_eng.xml