

High Voltage Chip Resistors

HVC Series

- Continuous voltages up to 3kV
- Overload voltages up to 4kV
- Values up to 1G0
- Tolerances to $\pm 0.5\%$
- TCR to $\pm 50\text{ppm}/^\circ\text{C}$
- Robust thick film construction
- Anti-sulphur version available

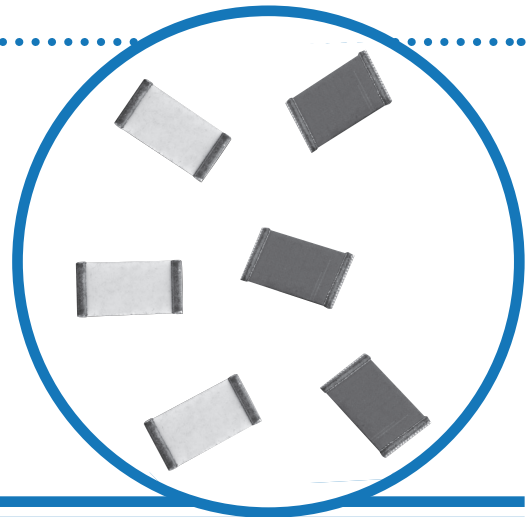

Electrical Data

		1206	2010	2512	Notes
Power rating @70°C	Watts	0.3	0.5	1	
Limiting element voltage	Volts	1000	2000	3000	DC or AC peak
Overload voltage (2s)	Volts	1500	3000	4000	
Resistance range	Ohms	10K to 1G0			Consult factory for out of range values
Resistance tolerance	%	0.5, 1, 2, 5, 10			See table of value ranges
TCR	ppm/°C	50, 100			
Ambient temperature range	°C	-55 to +155			
Values		E24 & E96 preferred			Any value to order
Thermal Impedance	°C/W	200	80	70	

Value Ranges (Ohms)

Size	TCR (ppm/°C)	Tolerance (%)		
		0.5	1 & 2	5 & 10
1206	50	-	10K to 10M	10K to 100M
	100	10K to 2M		10K to 1G0
2010 & 2512	50	-	10K to 100M	10K to 100M
	100	10K to 10M		10K to 1G0

Physical Data

Dimensions (mm) & Weight (g)							
	L	W	T	A	B	C	Wt.
1206	3.2±0.2	1.6±0.2	0.6±0.1	0.35±0.2	1.95 min	0.35±0.2	0.010
2010	5.1±0.2	2.5±0.2	0.7±0.1	0.45±0.2	3.70 min	0.4±0.25	0.035
2512	6.5±0.2	3.2±0.2	0.7±0.1	0.45±0.2	5.00 min	0.4±0.2	0.055

Wrap-around terminations (3 faces)

General Note

TT electronics reserves the right to make changes in product specification without notice or liability. All information is subject to TT electronics' own data and is considered accurate at time of going to print.

Construction

Resistive thick film material, overglaze and organic protection are screen printed on a 96% alumina substrate. The design and laser adjustment of the resistive element optimises the limiting element voltage of the resistor.

Terminations

The chips are supplied with wrap-around terminations suitable for soldering. Consult factory for alternative termination options.

Solderability

The terminations have an electroplated nickel barrier and tin finish. This ensures excellent 'leach' resistance properties and solderability.

Marking

The body protection is resistant to all normal cleaning solvents suitable for printed circuits. The chips are not marked and the relevant information on type, value, tolerance date code and quantity are recorded on the reel.

Performance Data

		Maximum	Typical
Load at rated power: 1000 hours rated load @ 70°C	ΔR%	1206: 2 2010/2512: 1	1206: 1 2010/2512: 0.25
Shelf life test: 12 months at room temperature	ΔR%	0.1	0.02
Derating from rated power at 70°C		Zero at 155°C	
Short term overload: Lesser of 6.25 x rated power or Maximum overload voltage	ΔR%	2	0.2
Lightning strike: 1.2/50μs & 10/700μs - see graph for peak voltage	ΔR%	0.5	0.2
Dry heat: 1000 hours at 155°C	ΔR%	0.5	0.1
Long term damp heat	ΔR%	1	0.25
Temperature rapid change	ΔR%	0.25	0.05
Resistance to solder heat	ΔR%	0.25	0.05
Resistance to sulphur-bearing gas (AS version only): ASTM-B-809		0.25	0.05
Voltage proof	Volts	500	
Voltage coefficient of resistance	ppm/V	1206: -25	1206: -15
		2010: -15	2010: -5
		2512 ≤100M: -5	2512 ≤100M: -1.5
		2512 >100M: -15	2512 >100M: -8

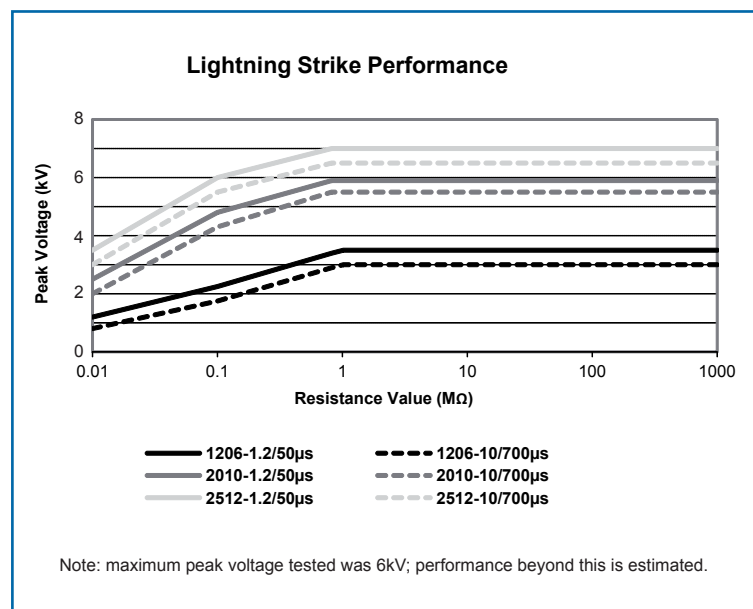
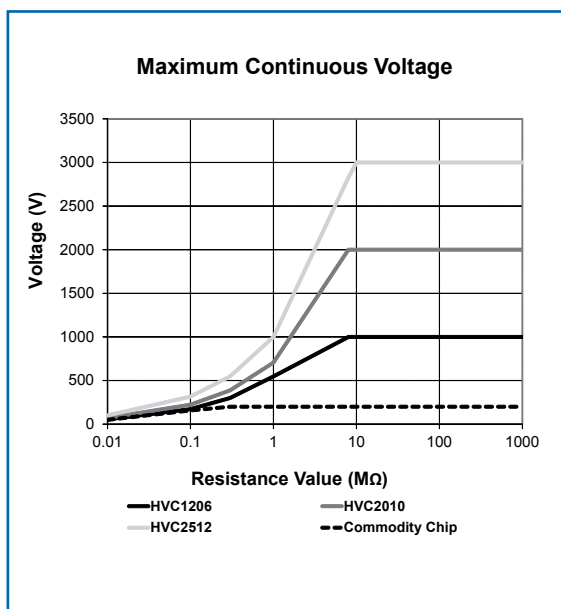

General Note

TT electronics reserves the right to make changes in product specification without notice or liability. All information is subject to TT electronics' own data and is considered accurate at time of going to print.

Application Notes

HVC resistors are ideally suited for handling by automatic methods due to their rectangular shape and the small dimensional tolerances. Electrical connection to a ceramic substrate or to a printed circuit board can be made by reflow or wave soldering of wrap-around terminations.

Wrap-around terminations provide good leach properties and ensure reliable contact. Due to the robust construction, the HVC can be immersed in the solder bath for 30 seconds at 260°C. This enables the resistor to be mounted on one side of a printed circuit board and wire-led components applied on the other side.

HVC resistors themselves can operate at a maximum

temperature of 155°C (see performance above). For soldered resistors, the joint temperature should not exceed 110°C. This condition is met when the stated power levels at 70°C are used.

The PCB layout should avoid tracks running between the HVC mounting pads, as this would compromise the LEV.

The LEV stated applies to operation at sea-level pressure, in a non-condensing atmosphere and non-contaminating environment. Voltage derating should be applied if low pressure, high humidity or contamination may be encountered. The termination clearance dimension (B) should be used in conjunction with the creepage limit applicable to the circuit application in order to determine the derated LEV.

Packaging

HVC Resistors are supplied taped and reeled as per IEC 286-3.

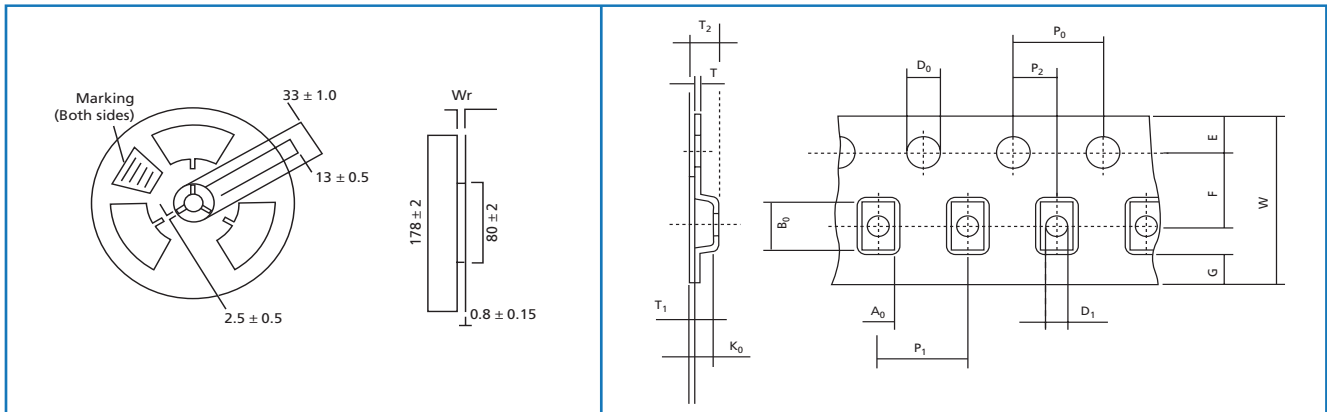

Tape and reel dimensions (mm)																Qty. per reel
Wr	W	P1	P0	P2	D0	D1	E	F	A0	B0	K0	T	T1	T2		
±0.5	±0.3	±0.1	±0.1	±0.05	±0.1	±0.2	±0.1	±0.05	±0.1	±0.1	±0.1	±0.05	Nom.	±0.15		
1206	9	8	4	4	2	1.5	1	1.75	3.5	1.95	3.55	1.0	0.2	0.05	1.3	3000
2010	13	12	8	4	2	1.5	1.5	1.75	5.5	2.79	5.89	0.91	0.28	0.06	1.21	3000
2512	13	12	8	4	2	1.5	1.5	1.75	5.5	3.61	6.96	1.17	0.28	0.06	1.45	1800

Ordering Procedure

Example: HVC2512 at 4.7 megohms and 1% tolerance on a reel of 1800 pieces -

Type **HVC** **2512** - **4M7** **F** **T 1 8**

Size Packing

TCR Tolerance (use IEC62 code) ·

T3	Tape	1206 or 2010	3000/reel	Standard
T18		2512	1800/reel	

Termination Standard terminations
AS Anti-sulphur terminations

D	0.5%	J	5%
F	1%	K	10%
G	2%		

Value (use IEC62 code)

General Note

TT electronics reserves the right to make changes in product specification without notice or liability. All information is subject to TT electronics' own data and is considered accurate at time of going to print.