

INA1x8 High-Side Measurement Current Shunt Monitor

1 Features

- Complete Unipolar High-Side Current Measurement Circuit
- Wide Supply and Common-Mode Range
- INA138: 2.7 V to 36 V
- INA168: 2.7 V to 60 V
- Independent Supply and Input Common-Mode Voltages
- Single Resistor Gain Set
- Low Quiescent Current (25 μ A Typical)
- Wide Temperature Range: -40°C to $+125^{\circ}\text{C}$
- 5-Pin SOT-23 Package

2 Applications

- Current Shunt Measurement:
 - Automotive, Telephone, Computers
- Portable and Battery-Backup Systems
- Battery Chargers
- Power Management
- Cell Phones
- Precision Current Source

3 Description

The INA138 and INA168 are high-side, unipolar, current shunt monitors. Wide input common-mode voltage range, low quiescent current, and tiny SOT-23 packaging enable use in a variety of applications.

Input common-mode and power-supply voltages are independent and can range from 2.7 V to 36 V for the INA138 and 2.7 V to 60 V for the INA168. Quiescent current is only 25 μ A, which permits connecting the power supply to either side of the current measurement shunt with minimal error.

The device converts a differential input voltage to a current output. This current is converted back to a voltage with an external load resistor that sets any gain from 1 to over 100. Although designed for current shunt measurement, the circuit invites creative applications in measurement and level shifting.

Both the INA138 and INA168 are available in SOT23-5 and are specified for the -40°C to 125°C temperature range.

Device Information⁽¹⁾

PART NUMBER	PACKAGE	BODY SIZE (NOM)
INA138	SOT-23 (5)	18.00 mm x 18.00 mm
INA168	SOT-23 (5)	18.00 mm x 18.00 mm

(1) For all available packages, see the orderable addendum at the end of the datasheet.

Typical Application Circuit

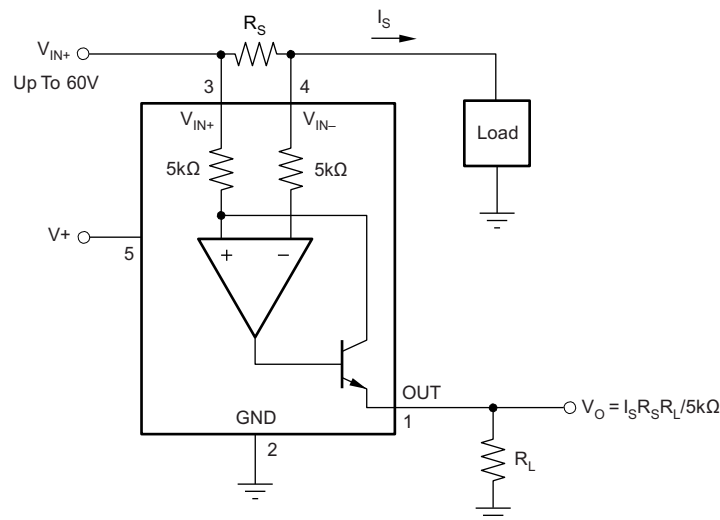

Table of Contents

1 Features	1	7.4 Device Functional Modes.....	9
2 Applications	1	8 Application and Implementation	10
3 Description	1	8.1 Application Information.....	10
4 Revision History	2	8.2 Typical Applications	11
5 Pin Configuration and Functions	3	9 Power Supply Recommendations	17
6 Specifications	4	10 Layout	18
6.1 Absolute Maximum Ratings	4	10.1 Layout Guidelines	18
6.2 ESD Ratings	4	10.2 Layout Example	18
6.3 Recommended Operating Conditions.....	4	11 Device and Documentation Support	19
6.4 Thermal Information	4	11.1 Documentation Support	19
6.5 Electrical Characteristics.....	5	11.2 Related Links	19
6.6 Typical Characteristics.....	6	11.3 Trademarks	19
7 Detailed Description	8	11.4 Electrostatic Discharge Caution.....	19
7.1 Overview	8	11.5 Glossary	19
7.2 Functional Block Diagram	8	12 Mechanical, Packaging, and Orderable	
7.3 Feature Description.....	8	Information	20

4 Revision History

Changes from Revision C (November 2005) to Revision D

Page

- Added *ESD Ratings* table, *Feature Description* section, *Device Functional Modes*, *Application and Implementation* section, *Power Supply Recommendations* section, *Layout* section, *Device and Documentation Support* section, and *Mechanical, Packaging, and Orderable Information* section. **1**

5 Pin Configuration and Functions

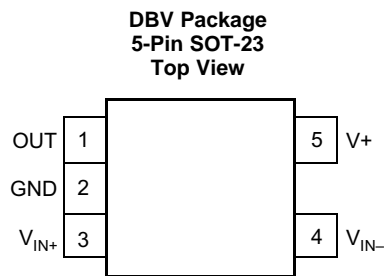

Pin Functions

PIN		I/O	DESCRIPTION
NO.	NAME		
1	OUT	O	Output current
2	GND	—	Ground
3	VIN+	I	Positive input voltage
4	V+	I	Power supply voltage
5	VIN-	I	Negative input voltage

6 Specifications

6.1 Absolute Maximum Ratings

 over operating free-air temperature range (unless otherwise noted) ⁽¹⁾

		MIN	MAX	UNIT	
V+	Supply voltage	INA138	-0.3	60	V
		INA168	-0.3	75	V
V _{IN+} , V _{IN-}	Analog inputs, INA138	Common mode ⁽²⁾	-0.3	60	V
		Differential (V _{IN+}) – (V _{IN-})	-40	2	V
	Analog inputs, INA168	Common mode ⁽²⁾	-0.3	75	V
		Differential (V _{IN+}) – (V _{IN-})	-40	2	V
Analog output, Out ⁽²⁾		-0.3	40	V	
Input current into any pin			10	mA	
Operating temperature		-55	150	°C	
Junction temperature			150	°C	
Storage temperature, T _{stg}		-65	150	°C	

- (1) Stresses beyond those listed under *Absolute Maximum Ratings* may cause permanent damage to the device. These are stress ratings only, which do not imply functional operation of the device at these or any other conditions beyond those indicated under *Recommended Operating Conditions*. Exposure to absolute-maximum-rated conditions for extended periods may affect device reliability.
- (2) The input voltage at any pin may exceed the voltage shown if the current at that pin is limited to 10mA.

6.2 ESD Ratings

		VALUE	UNIT
V _(ESD)	Electrostatic discharge	Human body model (HBM), per ANSI/ESDA/JEDEC JS-001, all pins ⁽¹⁾	±1000
		Charged device model (CDM), per JEDEC specification JESD22-C101, all pins ⁽²⁾	±500
			V

- (1) JEDEC document JEP155 states that 500-V HBM allows safe manufacturing with a standard ESD control process.
- (2) JEDEC document JEP157 states that 250-V CDM allows safe manufacturing with a standard ESD control process.

6.3 Recommended Operating Conditions

over operating free-air temperature range (unless otherwise noted)

		MIN	NOM	MAX	UNIT
INA138					
V+		2.7	5	36	V
Common Mode Voltage		2.7	12	36	V
INA168					
V+		2.7	5	60	V
Common Mode Voltage		2.7	12	60	V

6.4 Thermal Information

THERMAL METRIC ⁽¹⁾		INA1x8	UNIT
		DBV	
		5 PINS	
R _{θJA}	Junction-to-ambient thermal resistance	209.6	°C/W
R _{θJC(top)}	Junction-to-case (top) thermal resistance	196.8	
R _{θJB}	Junction-to-board thermal resistance	107.5	
Ψ _{JT}	Junction-to-top characterization parameter	36.2	
Ψ _{JB}	Junction-to-board characterization parameter	104.5	

- (1) For more information about traditional and new thermal metrics, see the *IC Package Thermal Metrics* application report, [SPRA953](#).

6.5 Electrical Characteristics

All other characteristics at $T_A = +25^\circ\text{C}$, $V_S = 5\text{V}$, $V_{IN+} = 12\text{V}$, and $R_{OUT} = 125\text{k}\Omega$, unless otherwise noted.

PARAMETER	TEST CONDITIONS	INA138			INA168			UNIT
		MIN	TYP	MAX	MIN	TYP	MAX	
INPUT								
Full-Scale Sense Voltage	$V_{SENSE} = V_{IN+} - V_{IN-}$		100	500		100	500	mV
Common-Mode Input Range		2.7		36	2.7		60	V
Common-Mode Rejection	$V_{IN+} = 2.7\text{V to } 40\text{V}$, $V_{SENSE} = 50\text{mV}$	100	120					dB
					100	120		dB
Offset Voltage			± 0.2	± 1		± 0.2	± 1	mV
Offset Voltage Over Temperature ⁽¹⁾	$T_A = -40^\circ\text{C to } +125^\circ\text{C}$			± 2			± 2	mV
Offset Voltage vs Temperature ⁽¹⁾	$T_A = -40^\circ\text{C to } +125^\circ\text{C}$		1			1		$\mu\text{V}/^\circ\text{C}$
Offset Voltage	$V_- = 2.7\text{V to } 40\text{V}$, $V_{SENSE} = 50\text{mV}$		0.1	10		1		$\mu\text{V/V}$
Offset Voltage vs Power Supply, V_+	$V_- = 2.7\text{V to } 60\text{V}$, $V_{SENSE} = 50\text{mV}$					0.1	10	$\mu\text{V/V}$
Input Bias Current			2			2		μA
Input Bias Current vs Temperature	$T_A = -40^\circ\text{C to } +125^\circ\text{C}$			10				μA
OUTPUT								
Transconductance	$T_A = +25^\circ\text{C}$, $V_{SENSE} = 10\text{mV} - 150\text{mV}$	198	200	202	198	200	202	$\mu\text{A/V}$
Transconductance vs Temperature	$V_{SENSE} = 100\text{mV}$, $T_A = -40^\circ\text{C to } +125^\circ\text{C}$	196		204	196		204	$\mu\text{A/V}$
Transconductance Over Temperature	$T_A = -40^\circ\text{C to } +125^\circ\text{C}$		10			10		$\text{nA}/^\circ\text{C}$
Nonlinearity Error	$V_{SENSE} = 10\text{mV to } 150\text{mV}$		$\pm 0.01\%$	$\pm 0.1\%$		$\pm 0.0\%$	$\pm 0.1\%$	
Total Output Error	$V_{SENSE} = 100\text{mV}$		$\pm 0.5\%$	$\pm 2\%$		$\pm 0.5\%$	$\pm 2\%$	
Total Output Error Over Temperature	$T_A = -40^\circ\text{C to } +125^\circ\text{C}$		$\pm 2.5\%$			$\pm 2.5\%$		
Output Impedance			1 5			1 5		$\text{G}\Omega \text{pF}$
Voltage Output Swing to Power Supply, V_+			(V_+) – 0.8	(V_+) – 1.0		(V_+) – 0.8	(V_+) – 1.0	V
Voltage Output Swing to Common Mode, V_{CM}			$V_{CM} - 0.5$	$V_{CM} - 0.8$		$V_{CM} - 0.5$	$V_{CM} - 0.8$	V
FREQUENCY RESPONSE								
Bandwidth	$R_{OUT} = 5\text{k}\Omega$		800			800		kHz
	$R_{OUT} = 125\text{k}\Omega$		32			32		kHz
Settling Time (0.1%)	5V Step, $R_{OUT} = 5\text{k}\Omega$		1.8			1.8		μs
	5V Step, $R_{OUT} = 125\text{k}\Omega$		30			30		μs
NOISE								
Output-Current Noise Density			9			9		$\text{pA}/\sqrt{\text{Hz}}$
Total Output-Current Noise	$\text{BW} = 100\text{kHz}$		3			3		nA RMS
POWER SUPPLY								
Operating Range, V_+		2.7		36	2.7		60	V
Quiescent Current	$T_A = +25^\circ\text{C}$, $V_{SENSE} = 0$, $I_O = 0$		25	45		25	45	μA
Quiescent Current Over Temperature	$T_A = -40^\circ\text{C to } +125^\circ\text{C}$			60			60	μA
TEMPERATURE RANGE								
Specification, T_{MIN} to T_{MAX}		-40		125	-40		125	$^\circ\text{C}$
Operating		-55		150	-55		150	$^\circ\text{C}$
Storage		-65		150	-65		150	$^\circ\text{C}$
Thermal Resistance, θ_{JA}			200			200		$^\circ\text{C/W}$

(1) Defined as the amount of input voltage, V_{SENSE} , to drive the output to zero.

6.6 Typical Characteristics

At $T_A = +25^\circ\text{C}$, $V_+ = 5\text{V}$, $V_{IN+} = 12\text{V}$, and $R_L = 125\text{k}\Omega$, unless otherwise noted.

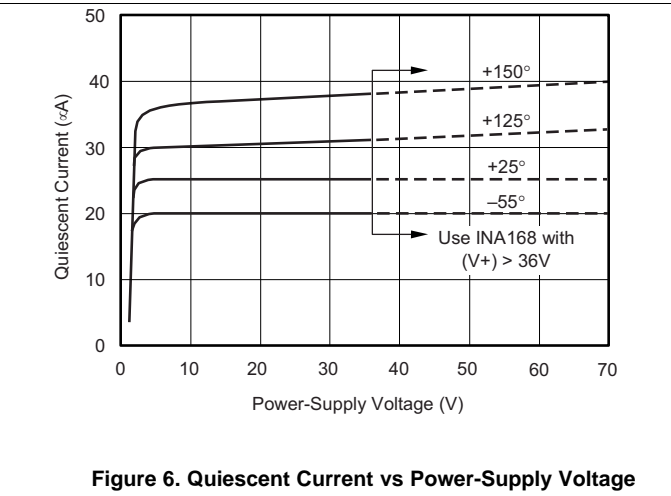
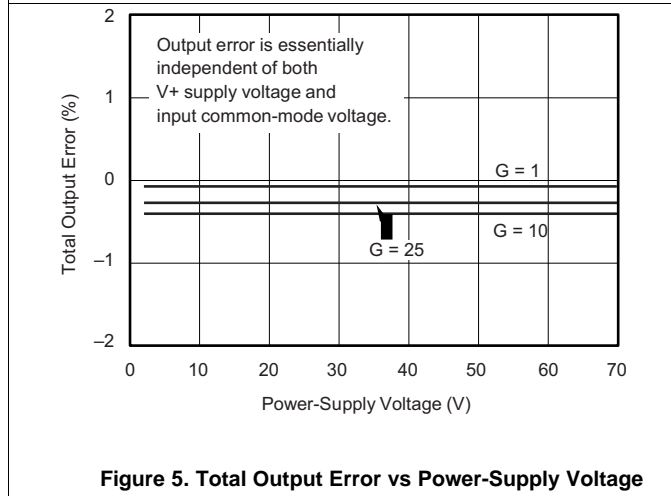
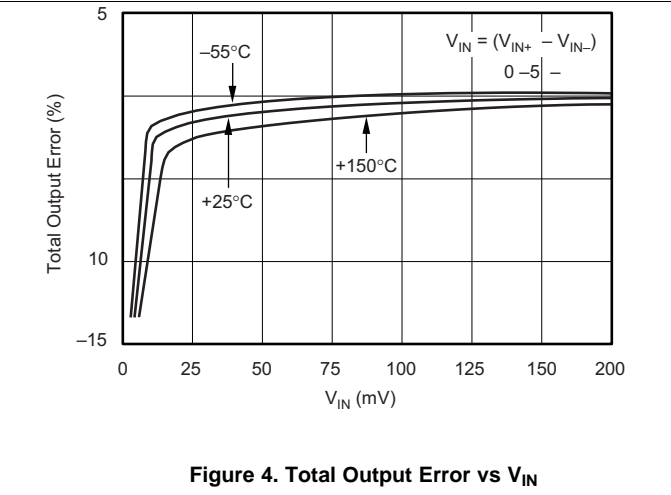
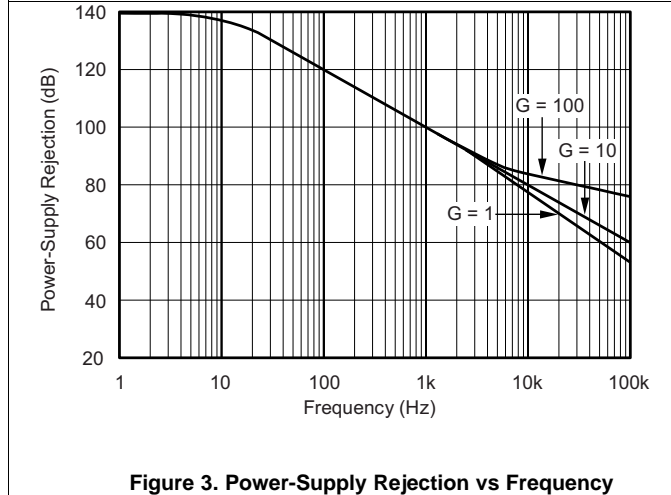
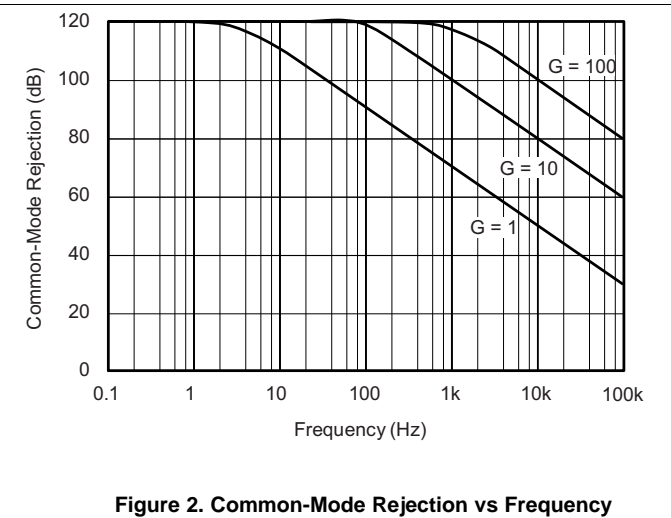
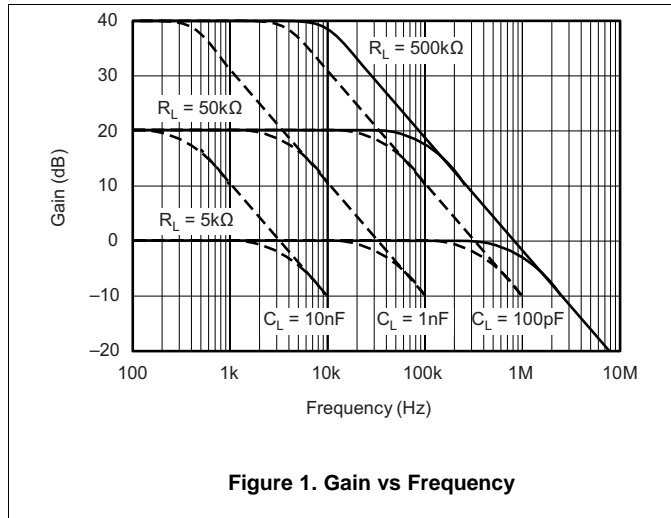

Typical Characteristics (continued)

At $T_A = +25^\circ\text{C}$, $V_+ = 5\text{V}$, $V_{IN+} = 12\text{V}$, and $R_L = 125\text{k}\Omega$, unless otherwise noted.

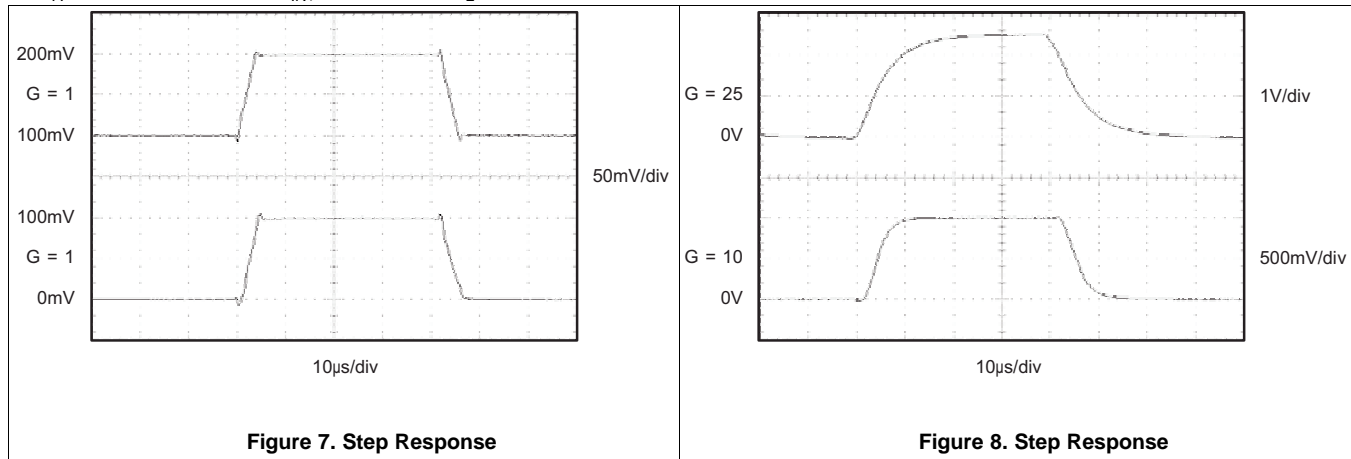

7 Detailed Description

7.1 Overview

The INA138 and INA168 devices are comprised of a high voltage, precision operational amplifier, precision thin film resistors trimmed in production to an absolute tolerance and a low noise output transistor. The INA138 and INA168 devices can be powered from a single power supply and their input voltages can exceed the power supply voltage. The INA138 and INA168 devices are ideal for measuring small differential voltages, such as those generated across a shunt resistor, in the presence of large common-mode voltages. Refer to [Functional Block Diagram](#) which illustrates the functional components within both INA138 and INA168 devices.

7.2 Functional Block Diagram

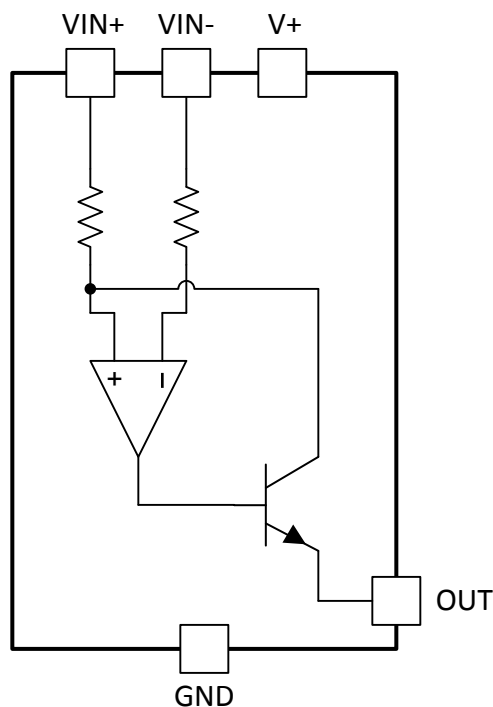

7.3 Feature Description

7.3.1 Output Voltage Range

The output of the INA138 device is a current, which is converted to a voltage by the load resistor, R_L . The output current remains accurate within the compliance voltage range of the output circuitry. The shunt voltage and the input common-mode and power-supply voltages limit the maximum possible output swing. The maximum output voltage compliance is limited by the lower of the following two equations:

$$V_{out\ max} = (V+) - 0.7\ V - (V_{IN+} - V_{IN-}) \quad (1)$$

or

$$V_{out\ max} = V_{IN-} - 0.5\ V \quad (2)$$

(whichever is lower)

Feature Description (continued)

7.3.2 Bandwidth

Measurement bandwidth is affected by the value of the load resistor, R_L . High gain produced by high values of R_L will yield a narrower measurement bandwidth (see [Typical Characteristics](#)). For widest possible bandwidth, keep the capacitive load on the output to a minimum. Reduction in bandwidth due to capacitive load is shown in the [Typical Characteristics](#).

If bandwidth limiting (filtering) is desired, a capacitor can be added to the output (see [Figure 12](#)). This will not cause instability.

7.4 Device Functional Modes

For proper operation the INA138 and INA168 devices must operate within their specified limits. Operating either device outside of their specified power supply voltage range or their specified common-mode range will result in unexpected behavior and is not recommended. Additionally operating the output beyond their specified limits with respect to power supply voltage and input common-mode voltage will also produce unexpected results. Refer to [Electrical Characteristics](#) for the device specifications.

8 Application and Implementation

NOTE

Information in the following applications sections is not part of the TI component specification, and TI does not warrant its accuracy or completeness. TI's customers are responsible for determining suitability of components for their purposes. Customers should validate and test their design implementation to confirm system functionality.

8.1 Application Information

8.1.1 Operation

Figure 9 illustrates the basic circuit diagram for both the INA138 and INA168 devices. Load current I_S is drawn from supply V_S through shunt resistor R_S . The voltage drop in shunt resistor V_S is forced across R_{G1} by the internal op amp, causing current to flow into the collector of Q1. External resistor R_L converts the output current to a voltage, V_{OUT} , at the OUT pin. The transfer function for the INA138 device is:

$$I_O = g_m(V_{IN+} - V_{IN-}) \quad (3)$$

where $g_m = 200 \mu A/V$.

In the circuit of Figure 9, the input voltage, $(V_{IN+} - V_{IN-})$, is equal to $I_S \times R_S$ and the output voltage, V_{OUT} , is equal to $I_O \times R_L$. The transconductance, g_m , of the INA138 device is $200 \mu A/V$. The complete transfer function for the current measurement amplifier in this application is:

$$V_{OUT} = (I_S) (R_S) (200 \mu A/V) (R_L) \quad (4)$$

The maximum differential input voltage for accurate measurements is 0.5 V, which produces a 100- μA output current. A differential input voltage of up to 2 V will not cause damage. Differential measurements (pins 3 and 4) must be unipolar with a more-positive voltage applied to pin 3. If a more-negative voltage is applied to pin 3, the output current, I_O , will be zero, but it will not cause damage.

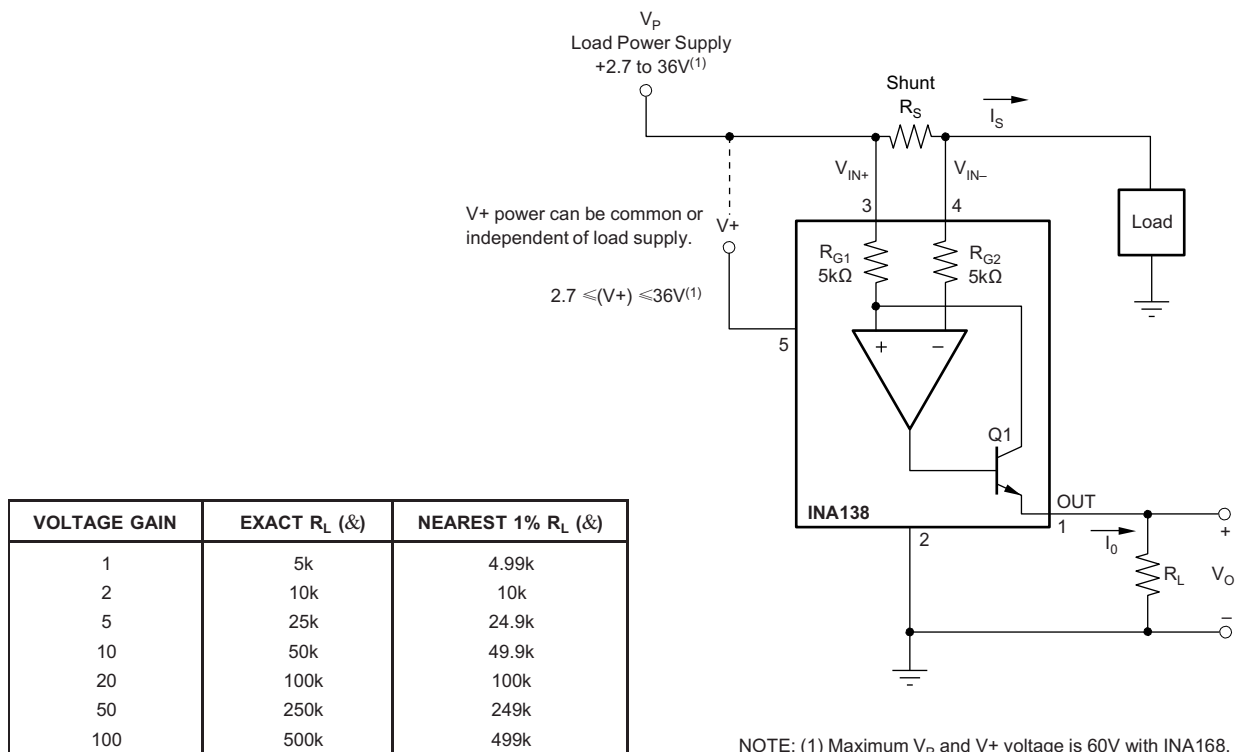

Figure 9. Basic Circuit Connections

8.2 Typical Applications

The INA138 device is designed for current shunt measurement circuits, as shown in Figure 9, but its basic function is useful in a wide range of circuitry. A creative engineer will find many unforeseen uses in measurement and level shifting circuits. A few ideas are illustrated in Figure 10 through Figure 18.

8.2.1 Buffering Output to Drive an ADC

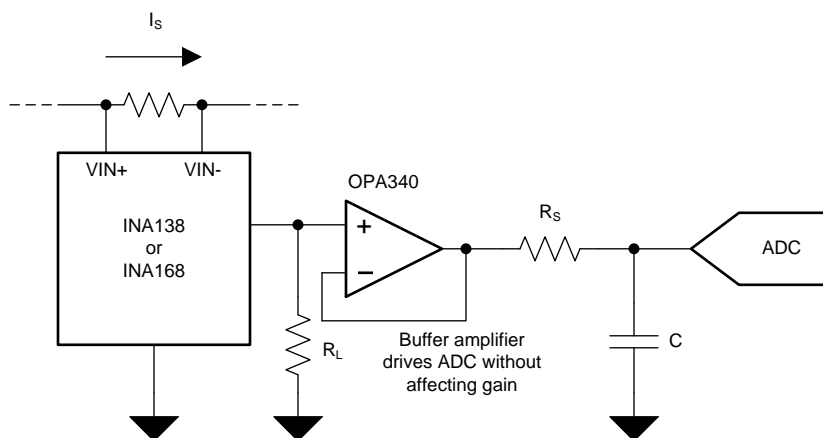

Figure 10. Buffering Output to Drive an A/D Converter

8.2.1.1 Design Requirements

Digitize the output of the INA138 or INA168 devices using a 1-MSPS analog-to-digital converter (ADC).

8.2.1.2 Detailed Design Procedure

8.2.1.2.1 Selecting the Shunt Resistor and R_L

In Figure 9 the value chosen for the shunt resistor depends on the application and is a compromise between small-signal accuracy and maximum permissible voltage loss in the measurement line. High values of shunt resistor provide better accuracy at lower currents by minimizing the effects of offset, while low values of shunt resistor minimize voltage loss in the supply line. For most applications, best performance is attained with a shunt resistor value that provides a full-scale shunt voltage range of 50 mV to 100 mV. Maximum input voltage for accurate measurements is 500 mV.

The load resistor, R_L , is chosen to provide the desired full-scale output voltage. The output impedance of the INA138 and INA168 OUT terminal is very high which permits using values of R_L up to 500 k Ω with excellent accuracy. The input impedance of any additional circuitry at the output should be much higher than the value of R_L to avoid degrading accuracy.

Some Analog-to-Digital (A/D) converters have input impedances that will significantly affect measurement gain. The input impedance of the A/D converter can be included as part of the effective R_L if its input can be modeled as a resistor to ground. Alternatively, an op amp can be used to buffer the A/D converter input. The INA138 and INA168 are current output devices, and as such have an inherently large output impedance. The output currents from the amplifier are converted to an output voltage via the load resistor, R_L , connected from the amplifier output to ground. The ratio of the load resistor value to that of the internal resistor value determines the voltage gain of the system.

In many applications digitizing the output of the INA138 or INA168 devices is required. This can be accomplished by connecting the output of the amplifier to an ADC. It is very common for an ADC to have a dynamic input impedance. If the INA138 or INA168 output is connected directly to an ADC input, the input impedance of the ADC is effectively connected in parallel with the gain setting resistor R_L . This parallel impedance combination will affect the gain of the system and the impact on the gain is difficult to estimate accurately. A simple solution that eliminates the paralleling of impedances, simplifying the gain of the circuit is to place a buffer amplifier, such as the OPA340, between the output of the INA138 or INA168 devices and the input to the ADC.

Typical Applications (continued)

Figure 10 illustrates this concept. Notice that a low pass filter is placed between the OPA340 output and the input to the ADC. The filter capacitor is required to provide any instantaneous demand for current required by the input stage of the ADC. The filter resistor is required to isolate the OPA340 output from the filter capacitor to maintain circuit stability. The values for the filter components will vary according to the operational amplifier used for the buffer and the particular ADC selected. More information can be found regarding the design of the low pass filter in the TI Precision Design *16 bit 1MSPS Data Acquisition Reference Design for Single-Ended Multiplexed Applications*, [TIPD173](#).

Figure 10 shows the expected results when driving an analog-to-digital converter at 1MSPS with and without buffering the INA138 or INA168 output. Without the buffer, the high impedance of the INA138 or INA168 will react with the input capacitance and sample and hold (S/H) capacitance of the analog-to-digital converter and will not allow the S/H to reach the correct final value before it is reset and the next conversion starts. Adding the buffer amplifier significantly reduces the output impedance driving the S/H and allows for higher conversion rates than can be achieved without adding the buffer.

8.2.1.3 Application Curve

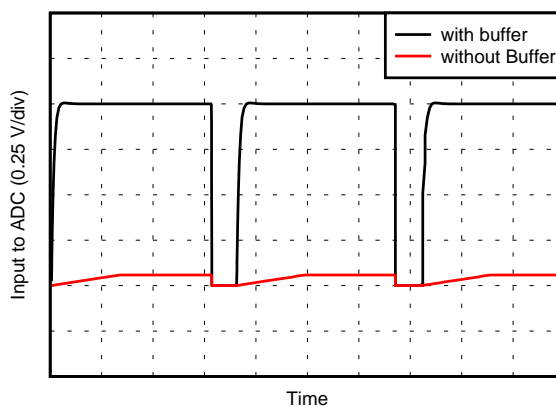

Figure 11. Driving an A/D with and without a Buffer

8.2.2 Output Filter

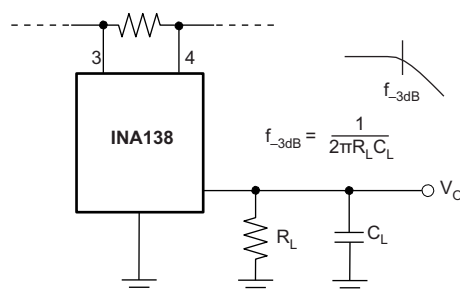

Figure 12. Output Filter

8.2.2.1 Design Requirements

Filter the output of the INA138 or INA168 devices.

Typical Applications (continued)

8.2.2.2 Detailed Design Procedure

A low-pass filter can be formed at the output of the INA138 or INA168 devices simply by placing a capacitor of the desired value in parallel with the load resistor. First determine the value of the load resistor needed to achieve the desired gain. Refer to the table in [Figure 9](#). Next, determine the capacitor value that will result in the desired cutoff frequency according to the equation shown in [Figure 12](#). [Figure 13](#) illustrates various combinations of gain settings (determined by R_L) and filter capacitors.

8.2.2.3 Application Curve

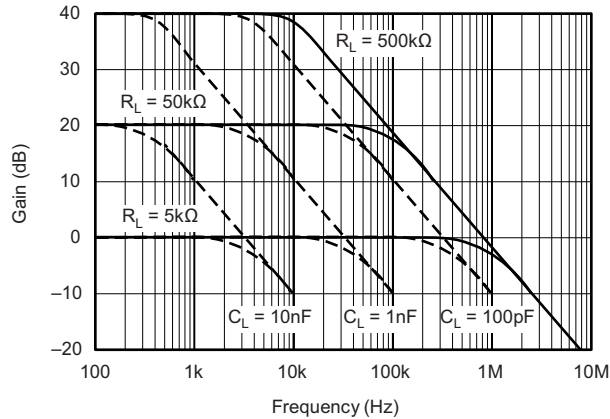
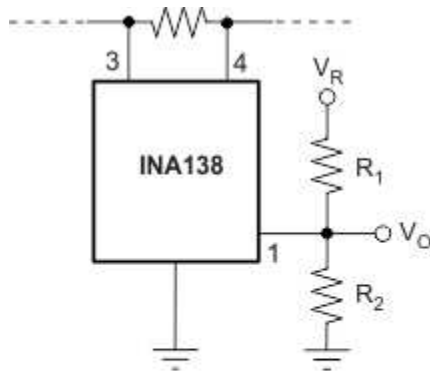

Figure 13. Gain vs Frequency

8.2.3 Offsetting the Output Voltage

For many applications using only a single power supply it may be required to level shift the output voltage away from ground when there is no load current flowing in the shunt resistor. Level shifting the output of the INA138 or INA168 devices is easily accomplished by one of two simple methods shown in [Figure 14](#). The method on the left hand side of [Figure 14](#) illustrates a simple voltage divider method. This method is useful for applications that require the output of the INA138 or INA168 devices to remain centered with respect to the power supply at zero load current through the shunt resistor. Using this method the gain is determined by the parallel combination of R_1 and R_2 while the output offset is determined by the voltage divider ratio R_1 and R_2 . For applications that may require a fixed value of output offset, independent of the power supply voltage, the current source method shown on the right-hand side of [Figure 14](#) is recommended. With this method a REF200 constant current source is used to generate a constant output offset. Using this method the gain is determined by R_L and the offset is determined by the product of the value of the current source and R_L .

Typical Applications (continued)

Gain Set by $R_1 \parallel R_2$
 Output Offset = $\frac{(V_R)R_2}{R_1 + R_2}$

a) Using resistor divider.

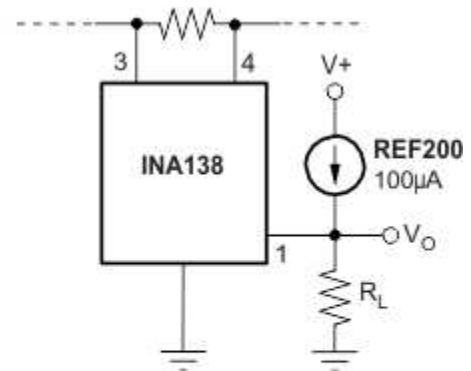

Gain Set by R_L
 Output Offset = $(100\mu\text{A}) \otimes R_L$
 (independent of V_+)

b) Using current source.

Figure 14. Offsetting the Output Voltage

8.2.4 Bipolar Current Measurement

The INA138 or INA168 devices can be configured as shown in [Figure 15](#) in applications where measuring current bi-directionally is required. Two INA devices are required connecting their inputs across the shunt resistor as shown in [Figure 15](#). A comparator, such as the [TLV3201](#), is used to detect the polarity of the load current. The magnitude of the load current is monitored across the resistor connected between ground and the connection labeled *Output*. In this example the 100-kΩ resistor results in a gain of 20 V/V. The 10-kΩ resistors connected in series with the INA138 or INA168 output current are used to develop a voltage across the comparator inputs. Two diodes are required to prevent current flow into the INA138 or INA168 output, as only one device at a time is providing current to the *Output* connection of the circuit. The circuit functionality is illustrated in [Figure 16](#).

Typical Applications (continued)

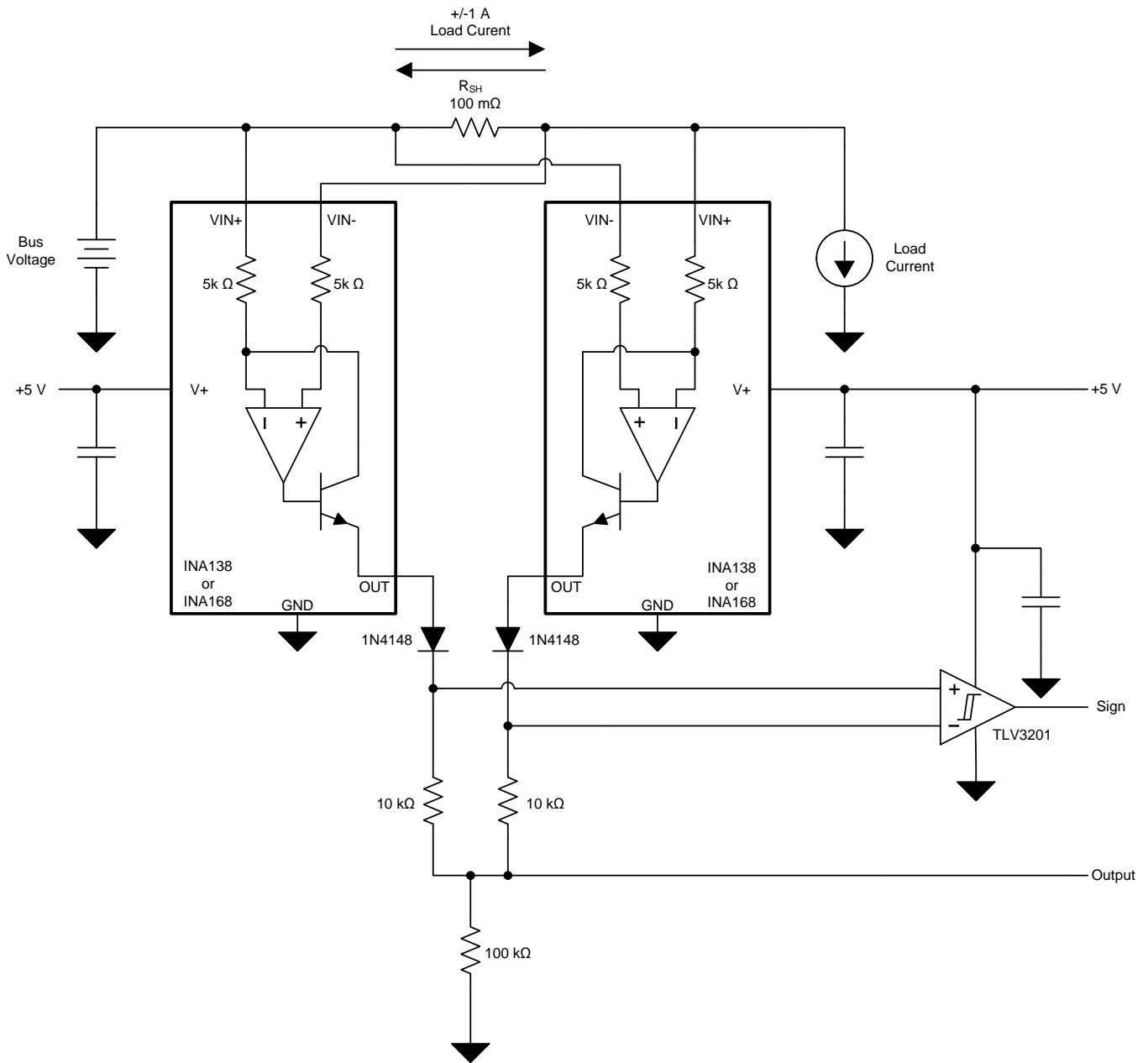
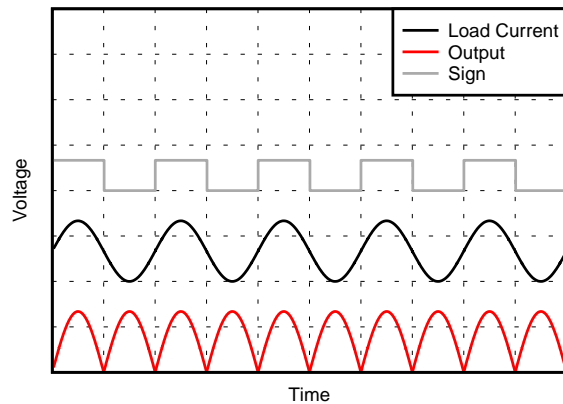
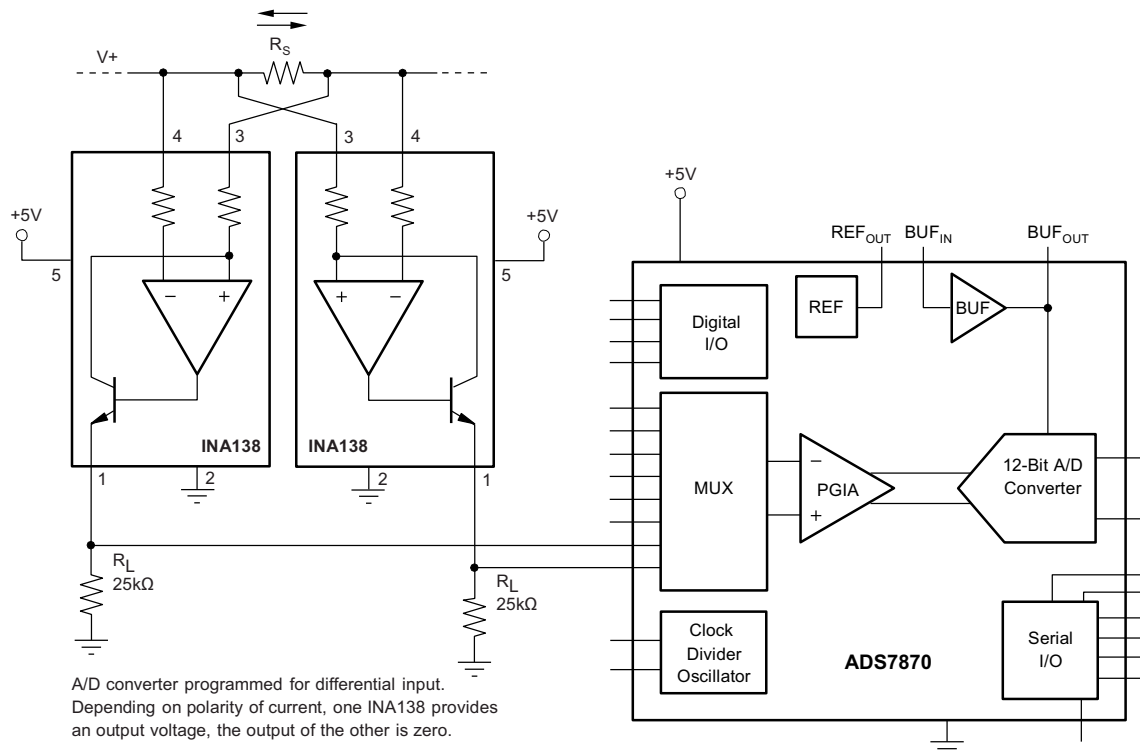

Figure 15. Bipolar Current Measurement

Typical Applications (continued)

Figure 16. Bipolar Current Measurements Results (arbitrary scale)
8.2.5 Bipolar Current Measurement Using Differential Input of A/D Converter

The INA138 or INA168 devices can be used with an A/D Converter such as the [ADS7870](#) programmed for differential mode operation. [Figure 17](#) illustrates this configuration. In this configuration the use of two INA's allows for bi-directional current measurement. Depending upon the polarity of the current, one of the INA's will provide an output voltage while the other output is zero. In this way the A/D converter will read the polarity of current directly, without the need for additional circuitry.

Figure 17. Bipolar Current Measurement Using Differential Input of A/D Converter

10 Layout

10.1 Layout Guidelines

Figure 19 shows the basic connection of the INA138 device. The input pins, V_{IN+} and V_{IN-} , should be connected as closely as possible to the shunt resistor to minimize any resistance in series with the shunt resistance. The output resistor, R_L , is shown connected between pin 1 and ground. Best accuracy is achieved with the output voltage measured directly across R_L . This is especially important in high-current systems where load current could flow in the ground connections, affecting the measurement accuracy.

No power-supply bypass capacitors are required for stability of the INA138. However, applications with noisy or high-impedance power supplies may require decoupling capacitors to reject power-supply noise. Connect bypass capacitors close to the device pins.

10.2 Layout Example

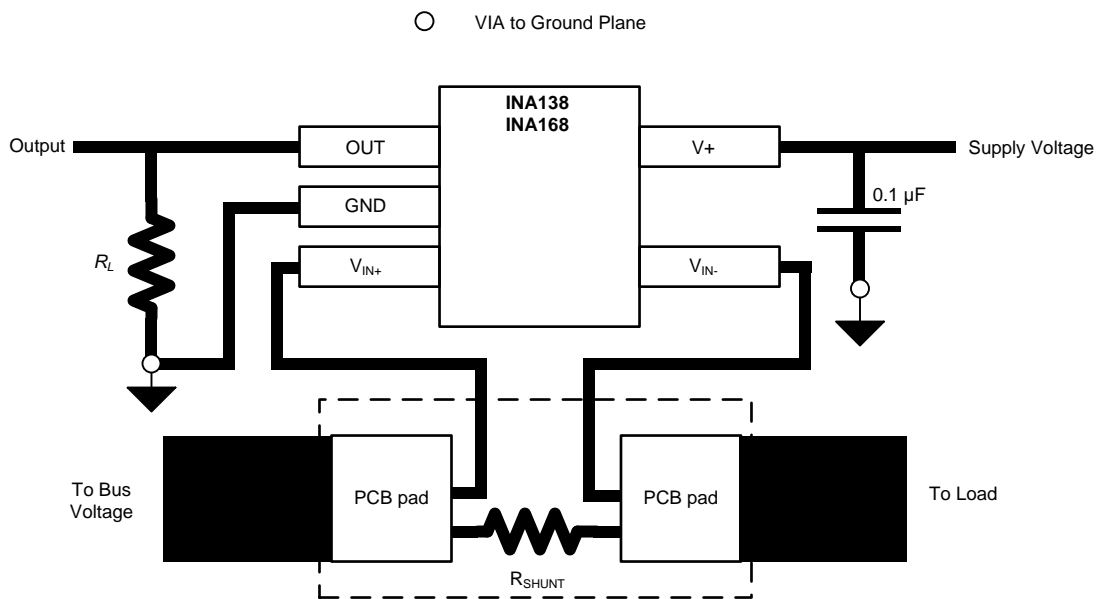

Figure 19. Typical Layout Example

11 Device and Documentation Support

11.1 Documentation Support

11.1.1 Related Documentation

For related documentation see the following:

- *16 bit 1MSPS Data Acquisition Reference Design for Single-Ended Multiplexed Applications*, [TIDU504](#)
- *ADS7870 12-Bit ADC, MUX, PGA and Internal Reference Data Acquisition System*, [SBAS124](#)
- *TLV3201, TLV3202 40-ns, microPOWER, Push-Pull Output Comparators*, [SBOS561](#)
- *REF200 Dual Current Source/Current Sink*, [SBVS020](#)

11.2 Related Links

The table below lists quick access links. Categories include technical documents, support and community resources, tools and software, and quick access to sample or buy.

Table 1. Related Links

PARTS	PRODUCT FOLDER	SAMPLE & BUY	TECHNICAL DOCUMENTS	TOOLS & SOFTWARE	SUPPORT & COMMUNITY
INA138	Click here	Click here	Click here	Click here	Click here
INA168	Click here	Click here	Click here	Click here	Click here

11.3 Trademarks

All trademarks are the property of their respective owners.

11.4 Electrostatic Discharge Caution



These devices have limited built-in ESD protection. The leads should be shorted together or the device placed in conductive foam during storage or handling to prevent electrostatic damage to the MOS gates.

11.5 Glossary

[SLYZ022](#) — *TI Glossary*.

This glossary lists and explains terms, acronyms, and definitions.

12 Mechanical, Packaging, and Orderable Information

The following pages include mechanical, packaging, and orderable information. This information is the most current data available for the designated devices. This data is subject to change without notice and revision of this document. For browser-based versions of this data sheet, refer to the left-hand navigation.

PACKAGING INFORMATION

Orderable Device	Status (1)	Package Type	Package Drawing	Pins	Package Qty	Eco Plan (2)	Lead/Ball Finish	MSL Peak Temp (3)	Op Temp (°C)	Top-Side Markings (4)	Samples
INA138NA/250	ACTIVE	SOT-23	DBV	5	250	Green (RoHS & no Sb/Br)	CU NIPDAU	Level-2-260C-1 YEAR	-40 to 125	B38	Samples
INA138NA/250G4	ACTIVE	SOT-23	DBV	5	250	Green (RoHS & no Sb/Br)	CU NIPDAU	Level-2-260C-1 YEAR	-40 to 125	B38	Samples
INA138NA/3K	ACTIVE	SOT-23	DBV	5	3000	Green (RoHS & no Sb/Br)	CU NIPDAU	Level-2-260C-1 YEAR	-40 to 125	B38	Samples
INA138NA/3KG4	ACTIVE	SOT-23	DBV	5	3000	Green (RoHS & no Sb/Br)	CU NIPDAU	Level-2-260C-1 YEAR	-40 to 125	B38	Samples
INA168NA/250	ACTIVE	SOT-23	DBV	5	250	Green (RoHS & no Sb/Br)	CU NIPDAU	Level-2-260C-1 YEAR		A68	Samples
INA168NA/250G4	ACTIVE	SOT-23	DBV	5	250	Green (RoHS & no Sb/Br)	CU NIPDAU	Level-2-260C-1 YEAR		A68	Samples
INA168NA/3K	ACTIVE	SOT-23	DBV	5	3000	Green (RoHS & no Sb/Br)	CU NIPDAU	Level-2-260C-1 YEAR	-40 to 125	A68	Samples
INA168NA/3KG4	ACTIVE	SOT-23	DBV	5	3000	Green (RoHS & no Sb/Br)	CU NIPDAU	Level-2-260C-1 YEAR	-40 to 125	A68	Samples

(1) The marketing status values are defined as follows:

ACTIVE: Product device recommended for new designs.

LIFEBUY: TI has announced that the device will be discontinued, and a lifetime-buy period is in effect.

NRND: Not recommended for new designs. Device is in production to support existing customers, but TI does not recommend using this part in a new design.

PREVIEW: Device has been announced but is not in production. Samples may or may not be available.

OBSOLETE: TI has discontinued the production of the device.

(2) Eco Plan - The planned eco-friendly classification: Pb-Free (RoHS), Pb-Free (RoHS Exempt), or Green (RoHS & no Sb/Br) - please check <http://www.ti.com/productcontent> for the latest availability information and additional product content details.

TBD: The Pb-Free/Green conversion plan has not been defined.

Pb-Free (RoHS): TI's terms "Lead-Free" or "Pb-Free" mean semiconductor products that are compatible with the current RoHS requirements for all 6 substances, including the requirement that lead not exceed 0.1% by weight in homogeneous materials. Where designed to be soldered at high temperatures, TI Pb-Free products are suitable for use in specified lead-free processes.

Pb-Free (RoHS Exempt): This component has a RoHS exemption for either 1) lead-based flip-chip solder bumps used between the die and package, or 2) lead-based die adhesive used between the die and leadframe. The component is otherwise considered Pb-Free (RoHS compatible) as defined above.

Green (RoHS & no Sb/Br): TI defines "Green" to mean Pb-Free (RoHS compatible), and free of Bromine (Br) and Antimony (Sb) based flame retardants (Br or Sb do not exceed 0.1% by weight in homogeneous material)

(3) MSL, Peak Temp. -- The Moisture Sensitivity Level rating according to the JEDEC industry standard classifications, and peak solder temperature.

⁽⁴⁾ Multiple Top-Side Markings will be inside parentheses. Only one Top-Side Marking contained in parentheses and separated by a "~" will appear on a device. If a line is indented then it is a continuation of the previous line and the two combined represent the entire Top-Side Marking for that device.

Important Information and Disclaimer: The information provided on this page represents TI's knowledge and belief as of the date that it is provided. TI bases its knowledge and belief on information provided by third parties, and makes no representation or warranty as to the accuracy of such information. Efforts are underway to better integrate information from third parties. TI has taken and continues to take reasonable steps to provide representative and accurate information but may not have conducted destructive testing or chemical analysis on incoming materials and chemicals. TI and TI suppliers consider certain information to be proprietary, and thus CAS numbers and other limited information may not be available for release.

In no event shall TI's liability arising out of such information exceed the total purchase price of the TI part(s) at issue in this document sold by TI to Customer on an annual basis.

OTHER QUALIFIED VERSIONS OF INA138, INA168 :

- Automotive: [INA138-Q1](#), [INA168-Q1](#)

NOTE: Qualified Version Definitions:

- Automotive - Q100 devices qualified for high-reliability automotive applications targeting zero defects

TAPE AND REEL INFORMATION

QUADRANT ASSIGNMENTS FOR PIN 1 ORIENTATION IN TAPE

*All dimensions are nominal

Device	Package Type	Package Drawing	Pins	SPQ	Reel Diameter (mm)	Reel Width W1 (mm)	A0 (mm)	B0 (mm)	K0 (mm)	P1 (mm)	W (mm)	Pin1 Quadrant
INA138NA/250	SOT-23	DBV	5	250	178.0	9.0	3.3	3.2	1.4	4.0	8.0	Q3
INA138NA/3K	SOT-23	DBV	5	3000	178.0	9.0	3.3	3.2	1.4	4.0	8.0	Q3
INA168NA/250	SOT-23	DBV	5	250	178.0	9.0	3.23	3.17	1.37	4.0	8.0	Q3
INA168NA/3K	SOT-23	DBV	5	3000	178.0	9.0	3.23	3.17	1.37	4.0	8.0	Q3

TAPE AND REEL BOX DIMENSIONS

*All dimensions are nominal

Device	Package Type	Package Drawing	Pins	SPQ	Length (mm)	Width (mm)	Height (mm)
INA138NA/250	SOT-23	DBV	5	250	180.0	180.0	18.0
INA138NA/3K	SOT-23	DBV	5	3000	180.0	180.0	18.0
INA168NA/250	SOT-23	DBV	5	250	180.0	180.0	18.0
INA168NA/3K	SOT-23	DBV	5	3000	180.0	180.0	18.0

DBV (R-PDSO-G5)

PLASTIC SMALL OUTLINE



- NOTES:
- A. All linear dimensions are in millimeters.
 - B. This drawing is subject to change without notice.
 - C. Customers should place a note on the circuit board fabrication drawing not to alter the center solder mask defined pad.
 - D. Publication IPC-7351 is recommended for alternate designs.
 - E. Laser cutting apertures with trapezoidal walls and also rounding corners will offer better paste release. Customers should contact their board assembly site for stencil design recommendations. Example stencil design based on a 50% volumetric metal load solder paste. Refer to IPC-7525 for other stencil recommendations.

IMPORTANT NOTICE

Texas Instruments Incorporated and its subsidiaries (TI) reserve the right to make corrections, enhancements, improvements and other changes to its semiconductor products and services per JESD46, latest issue, and to discontinue any product or service per JESD48, latest issue. Buyers should obtain the latest relevant information before placing orders and should verify that such information is current and complete. All semiconductor products (also referred to herein as "components") are sold subject to TI's terms and conditions of sale supplied at the time of order acknowledgment.

TI warrants performance of its components to the specifications applicable at the time of sale, in accordance with the warranty in TI's terms and conditions of sale of semiconductor products. Testing and other quality control techniques are used to the extent TI deems necessary to support this warranty. Except where mandated by applicable law, testing of all parameters of each component is not necessarily performed.

TI assumes no liability for applications assistance or the design of Buyers' products. Buyers are responsible for their products and applications using TI components. To minimize the risks associated with Buyers' products and applications, Buyers should provide adequate design and operating safeguards.

TI does not warrant or represent that any license, either express or implied, is granted under any patent right, copyright, mask work right, or other intellectual property right relating to any combination, machine, or process in which TI components or services are used. Information published by TI regarding third-party products or services does not constitute a license to use such products or services or a warranty or endorsement thereof. Use of such information may require a license from a third party under the patents or other intellectual property of the third party, or a license from TI under the patents or other intellectual property of TI.

Reproduction of significant portions of TI information in TI data books or data sheets is permissible only if reproduction is without alteration and is accompanied by all associated warranties, conditions, limitations, and notices. TI is not responsible or liable for such altered documentation. Information of third parties may be subject to additional restrictions.

Resale of TI components or services with statements different from or beyond the parameters stated by TI for that component or service voids all express and any implied warranties for the associated TI component or service and is an unfair and deceptive business practice. TI is not responsible or liable for any such statements.

Buyer acknowledges and agrees that it is solely responsible for compliance with all legal, regulatory and safety-related requirements concerning its products, and any use of TI components in its applications, notwithstanding any applications-related information or support that may be provided by TI. Buyer represents and agrees that it has all the necessary expertise to create and implement safeguards which anticipate dangerous consequences of failures, monitor failures and their consequences, lessen the likelihood of failures that might cause harm and take appropriate remedial actions. Buyer will fully indemnify TI and its representatives against any damages arising out of the use of any TI components in safety-critical applications.

In some cases, TI components may be promoted specifically to facilitate safety-related applications. With such components, TI's goal is to help enable customers to design and create their own end-product solutions that meet applicable functional safety standards and requirements. Nonetheless, such components are subject to these terms.

No TI components are authorized for use in FDA Class III (or similar life-critical medical equipment) unless authorized officers of the parties have executed a special agreement specifically governing such use.

Only those TI components which TI has specifically designated as military grade or "enhanced plastic" are designed and intended for use in military/aerospace applications or environments. Buyer acknowledges and agrees that any military or aerospace use of TI components which have **not** been so designated is solely at the Buyer's risk, and that Buyer is solely responsible for compliance with all legal and regulatory requirements in connection with such use.

TI has specifically designated certain components as meeting ISO/TS16949 requirements, mainly for automotive use. In any case of use of non-designated products, TI will not be responsible for any failure to meet ISO/TS16949.

Products

Audio	www.ti.com/audio
Amplifiers	amplifier.ti.com
Data Converters	dataconverter.ti.com
DLP® Products	www.dlp.com
DSP	dsp.ti.com
Clocks and Timers	www.ti.com/clocks
Interface	interface.ti.com
Logic	logic.ti.com
Power Mgmt	power.ti.com
Microcontrollers	microcontroller.ti.com
RFID	www.ti-rfid.com
OMAP Applications Processors	www.ti.com/omap
Wireless Connectivity	www.ti.com/wirelessconnectivity

Applications

Automotive and Transportation	www.ti.com/automotive
Communications and Telecom	www.ti.com/communications
Computers and Peripherals	www.ti.com/computers
Consumer Electronics	www.ti.com/consumer-apps
Energy and Lighting	www.ti.com/energy
Industrial	www.ti.com/industrial
Medical	www.ti.com/medical
Security	www.ti.com/security
Space, Avionics and Defense	www.ti.com/space-avionics-defense
Video and Imaging	www.ti.com/video

TI E2E Community

e2e.ti.com