

DI5022

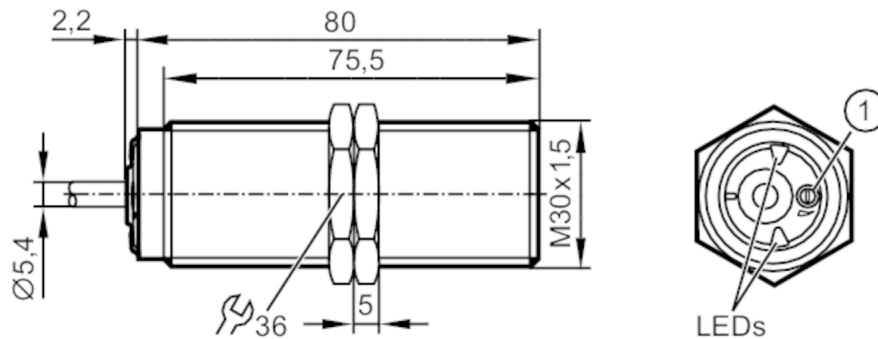

Compact evaluation unit for speed monitoring

DIA3010-ZPKG



1 potentiometer



Product characteristics

Electrical design	PNP
Output function	normally open
Sensing range [mm]	10
Housing	threaded type
Dimensions [mm]	M30 x 1.5 / L = 80

Application

Application	simple evaluation of rotating and linear movement with regard to underspeed; blocking
-------------	---

Electrical data

Nominal voltage DC [V]	10...36
Current consumption [mA]	< 20
Protection class	III
Reverse polarity protection	yes

Outputs

Total number of outputs	1
Electrical design	PNP
Output function	normally open
Max. voltage drop switching output DC [V]	2.5
Permanent current rating of switching output DC [mA]	250
Short-time current rating of switching output [mA]	250
Short-circuit proof	yes
Overload protection	yes

Detection zone

Sensing range [mm]	10
Sensing range adjustable	no
Operating distance [mm]	0...8.1

Measuring/setting range

Setting range [Imp/min]	5...3600
-------------------------	----------

DI5022



Compact evaluation unit for speed monitoring

DIA3010-ZPKG

Accuracy / deviations		
Correction factor		steel: 1 / stainless steel: 0.7 / brass: 0.5 / aluminium: 0.4 / copper: 0.3
Hysteresis	[% of Sr]	10
Response times		
Start-up delay	[s]	0
Max. damping frequency	[Imp/min]	18000
Software / programming		
Adjustment of the switch point		multiturn potentiometer
Operating conditions		
Ambient temperature	[°C]	-25...80
Storage temperature	[°C]	-25...80
Protection		IP 65; IP 67
Tests / approvals		
MTTF	[years]	656
Mechanical data		
Weight	[g]	301.5
Housing		threaded type
Mounting		flush mountable
Dimensions	[mm]	M30 x 1.5 / L = 80
Thread designation		M30 x 1.5
Materials		brass special coating; PA; TPE-U
Tightening torque	[Nm]	50
Displays / operating elements		
Display	switching status	1 x LED, green
Accessories		
Accessories (supplied)		lock nuts: 2

DI5022



Compact evaluation unit for speed monitoring

DIA3010-ZPKG

Electrical connection

Cable: 2 m, PUR; 3 x 0.5 mm²

Connection

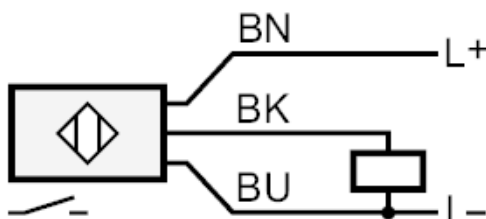

Core colours :

BK = black
BN = brown
BU = blue