

Booster Regulator/Air Tank

New

Increase factory air pressure by up to twice as much!
Air-only operation requires no power supply, reduces heat generation, and allows easy installation.

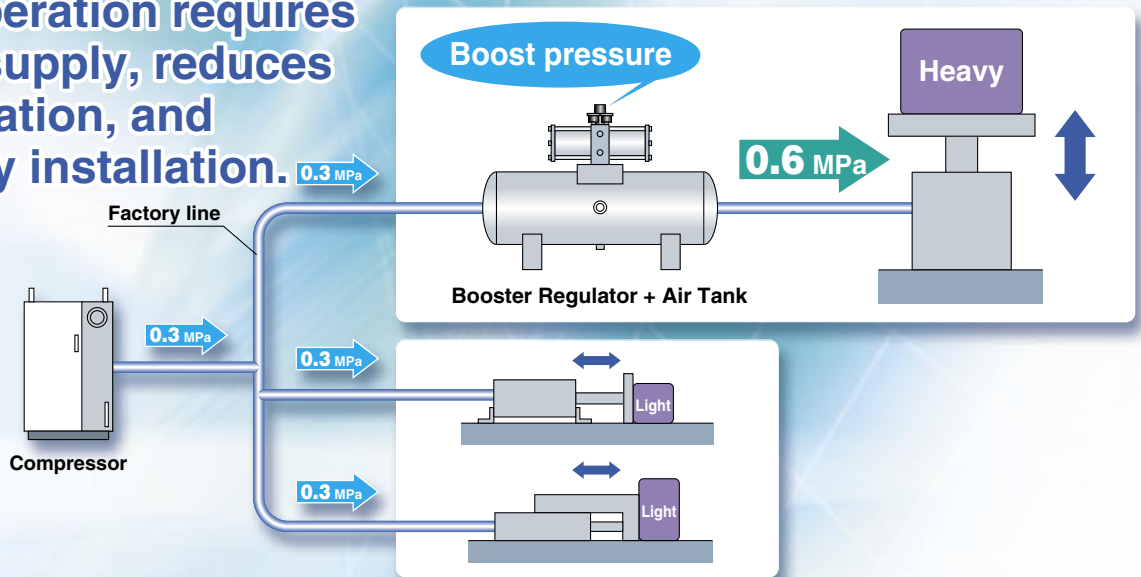

No power supply or wiring needed

There is no need to install dedicated electrical wiring.

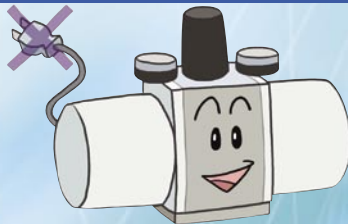

Easy installation

Simply insert the unit in the air line. Requires far less space than upgrading the compressor.

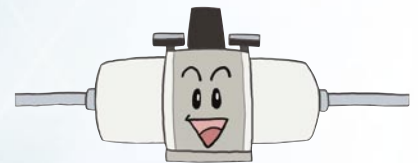

Low heat generation

Very little heat is generated because no electricity is used, and there is no impact on cylinders, solenoid valves, etc.

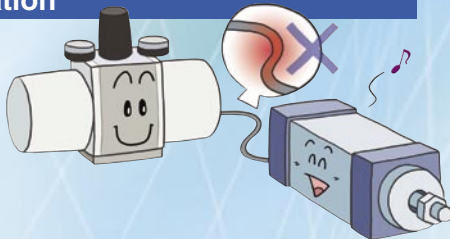

Air-only operation

Operation is safe because no electricity is used.

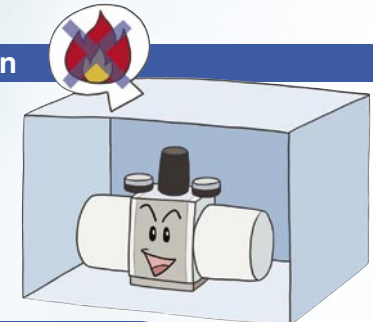

New product added to the VBA10A series!



Booster regulator/Series VBA



Air tank/Series VBAT

Series VBA/VBAT



CAT.EUS11-96C-UK

Booster Regulator Series VBA

Improved service life

Doubled*
that of conventional model

- Floating piston structure (PAT. PEND)
- Grease retaining groove

* Except for VBA1111.

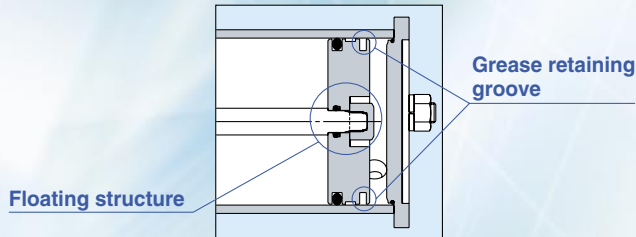

Reduced noise

Reduced by **13 dB (A)**
compared with the conventional model

- Metal noise reduced by a damper on the impact part of the switch valve
- Exhaust noise reduced by a high-noise reduction silencer

* Except for VBA1111.

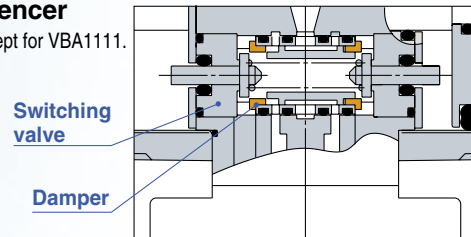

Improved reliability

Built-in mesh filter* at the IN port

- Prevents operation failure due to foreign matter.

* Except for VBA1111.

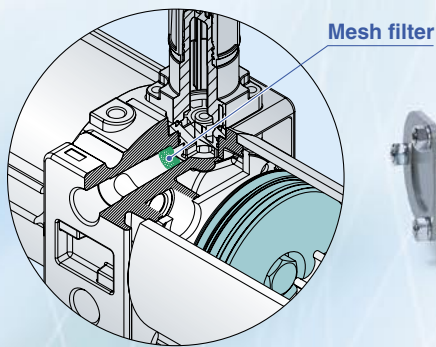

Anti-condensation

Integrated air-feeding tube with the main tube

- Mitigates the condensation caused by cooling during exhaust expansion.

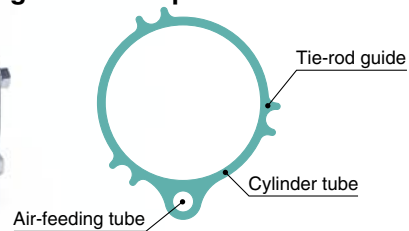

1/8" gauge ports

Allows the use of standard fittings for remote pressure monitoring and the like.

* Gauge ports changed from 1/16" to 1/8".



NEW VBA10A

Air-operated type

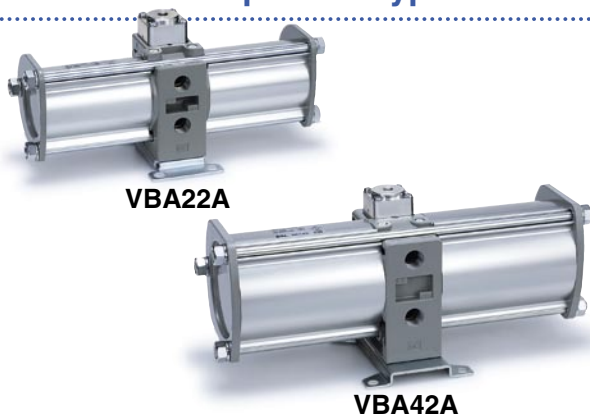

Max. operating pressure 1.6 MPa



Fourfold pressure increase type



Body size	Operation	Handle-operated type (Direct operation)			Air-operated type (Remote operation)
	Set pressure range	0.2 to 1.0 MPa	0.2 to 1.6 MPa (2.0 MPa)	0.2 to 2.0 MPa	0.2 to 1.0 MPa
1/4"		_____	VBA10A 	VBA1111 	_____
3/8"		VBA20A-03 	_____		VBA22A-03 
1/2"		VBA40A-04 	VBA43A-04 		VBA42A-04 

Air Tank Series VBAT

Perfect fit with a booster regulator

This is an air tank to which a booster regulator can be connected compactly. It can be used alone as a tank. The pressure vessel law is different from country to country, so as an air tank suitable to a country needs to be confirmed.

Extensive product lineup

To meet a variety of usage environment and pressure specifications, models are available in two materials four sizes ranging from 5 liters to 38 liters.

Model	VBAT05A	VBAT10A	VBAT20A	VBAT38A
Tank capacity (ℓ)	5	10	20	38
Max. operating pressure (MPa)	2.0		1.0	
Material	Carbon steel			



Booster Regulator Series VBA

How to Order



Made to Order

(For details, refer to page 11.)

Series VBA 10A
2□A
4□A

VBA 40A - 04 GN -

Body size

10A	1/4, Handle-operated type
20A	3/8, Handle-operated type
40A	1/2, Handle-operated type
22A	3/8, Air-operated type
42A	1/2, Air-operated type
43A	1/2, Max. operating pressure 1.6 MPa

* Pressure increase ratio: Twice

Thread type Note)

Symbol	Thread type
—	Rc
F	G
N	NPT
T	NPTF

Note) Thread types apply to the IN, OUT, and EXH ports of the VBA10A and to the IN, OUT, EXH, and gauge ports of the VBA2□A and VBA4□A. The gauge ports of the VBA10A are Rc thread type regardless of the thread type indication.

Semi-standard

Symbol	Specifications
—	Pressure unit on the product name label and pressure gauge: MPa
Z <small>Note)</small>	Pressure unit on the product name label and pressure gauge: psi

Note) Thread type: NPT, NPTF

The SI unit type is provided for use in Japan. This product is for use outside of Japan only according to the new Measurement Law.

Option

Symbol	Option
—	None
G	Pressure gauge
N	Silencer
S	High-noise reduction silencer <small>Note)</small>
GN	Pressure gauge, Silencer
GS	Pressure gauge, High-noise reduction silencer <small>Note)</small>

Note) The high-noise reduction silencer is not available on the VBA10A-N02 and VBA10A-T02.

Port size

Symbol	Port size	Applicable series
02	1/4	VBA10A
03	3/8	VBA2□A
04	1/2	VBA4□A

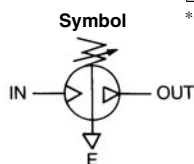

Air tank compatibility chart

Air tank	Booster regulator		
	VBA10A VBA1111	VBA2□A	VBA4□A
VBAT05A	●	—	—
VBAT10A	●	●	—
VBAT20A	—	●	●
VBAT38A	—	●	●

Series VBA1111

VBA 111 1 - 02 GN

Body size

111	1/4
-----	-----

* Pressure: 2 MPa

Pressure increase ratio

1	4 times
---	---------

Thread type Note)

Symbol	Thread type
—	Rc
F	G
N	NPT
T	NPTF

Option

Symbol	Option
—	None
G	Pressure gauge
N	Silencer
GN	Pressure gauge, Silencer

Port size

Symbol	Port size
02	1/4

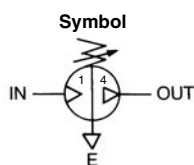

Note) Thread types apply to the IN, OUT, and EXH ports. The gauge ports are Rc thread type.

For the G thread type, add an E at the beginning of the model number (EVBA1111-F02□).

For the NPTF thread type, add an N at the beginning of the model number (NVBA1111-T02□).

Standard Specifications

Model	VBA10A-02	VBA20A-03	VBA40A-04	VBA22A-03	VBA42A-04	VBA43A-04	VBA1111-02
Fluid	Compressed air						
Pressure increase ratio	Twice					Twice	Twice to 4 times
Pressure adjustment mechanism	Handle-operated with relief mechanism ^{Note 1)}			Air-operated		Handle-operated with relief mechanism ^{Note 1)}	
Max. flow rate ^{Note 2)} (l/min (ANR))	230	1000	1900	1000	1900	1600	60
Set pressure range (MPa)	0.2 to 2.0	0.2 to 1.0		0.2 to 1.0		0.2 to 1.6	0.2 to 2.0
Supply pressure range (MPa)	0.1 to 1.0						
Proof pressure (MPa)	3	1.5		1.5		2.4	3
Port size (IN/OUT/EXH: 3 locations) (Rc)	1/4	3/8	1/2	3/8	1/2	1/2	1/4
Pressure gauge port size (IN/OUT: 2 locations) (Rc)	1/8	1/8	1/8	1/8	1/8	1/8	1/16
Ambient and fluid temperature (°C)	2 to 50 (No freezing)						
Installation	Horizontal						
Lubrication	Grease (Non-lube)						
Weight (kg)	0.84	3.9	8.6	3.9	8.6	8.6	0.98

Note 1) If the OUT pressure is higher than the set pressure by the handle, excessive pressure is exhausted from the back of the handle.

Note 2) Flow rate at IN= OUT= 0.5 MPa. The pressure varies depending on the operating conditions. Refer to "Flow Characteristics" on pages 3 and 4.

Options/Part No.

Pressure Gauge, Silencer (When thread type is Rc or G.)

Model	VBA10A-02	VBA20A-03	VBA40A-04	VBA22A-03	VBA42A-04	VBA43A-04	VBA1111-02
Description	VBA10A-F02	VBA20A-F03	VBA40A-F04	VBA22A-F03	VBA42A-F04	VBA43A-F04	EVBA1111-F02
Pressure gauge	G G27-20-01	G36-10-01		KT-VBA22A-7	G36-10-01	G27-20-01	G27-20-R1
Silencer	N AN200-02	AN300-03	AN400-04	AN300-03	AN400-04	AN400-04	AN200-02
High-noise reduction silencer	S ANA1-02	ANA1-03	ANA1-04	ANA1-03	ANA1-04	ANA1-04	—

Note 1) In the case of option GN, two pressure gauges and one silencer are included as accessories.

Note 2) KT-VBA22A-7 is a pressure gauge with fittings. (Please order two units when using with IN and OUT.)

Note 3) Only simple indication of MPA for the pressure gauges

Pressure Gauge, Silencer (When thread type is NPT or NPTF.)

Model	VBA10A-N02 *	VBA20A-N03 *	VBA40A-N04 *	VBA22A-N03 *	VBA42A-N04 *	VBA43A-N04 *	VBA1111-N02
Description	VBA10A-T02 *	VBA20A-T03 *	VBA40A-T04 *	VBA22A-T03 *	VBA42A-T04 *	VBA43A-T04 *	NVBA1111-T02
	*: when "-Z"						
Pressure gauge *: no symbol ^{Note 6)}	G G27-20-01	G36-10-N01		KT-VBA22A-7N	G36-10-N01	G27-20-N01	G27-20-R1-X214 ^{Note 5)}
Pressure gauge *: when "-Z" ^{Note 4)}	G G27-P20-01	G36-P10-N01		KT-VBA22A-8N	G36-P10-N01	G27-P20-N01	—
Silencer	N AN200-N02	AN300-N03	AN400-N04	AN300-N03	AN400-N04	AN400-N04	AN200-N02
High-noise reduction silencer	S —	ANA1-N03	ANA1-N04	ANA1-N03	ANA1-N04	ANA1-N04	—

Note 1) In the case of option GN, two pressure gauges and one silencer are included as accessories.

Note 2) KT-VBA22A-7N, KT-VBA22A-8N are pressure gauges with fittings. (Please order two units when using with IN and OUT.)

Note 3) Under the new measurement law, the pressure unit of "psi" on the pressure gauges cannot be used in Japan.

Note 4) Pressure unit of pressure gauge: psi

Note 5) Pressure unit of pressure gauge: psi and MPa

Note 6) Only simple indication of MPA for the pressure gauges

Related Products/Part No.

Mist Separator, Exhaust Cleaner

Model	For VBA10A-02	For VBA20A-03	For VBA40A-04
Description	For VBA1111-02	For VBA22A-03	For VBA42A-04
	For VBA43A-04		
Mist separator	AM250C-02	AM450C-04, 06	AM550C-06, 10
Exhaust cleaner	AMC310-03	AMC510-06	AMC610-10

Note) Refer to page 12 for air tanks, Best Pneumatics No. 5 for mist separators and Best Pneumatics No. 6 for exhaust cleaners.

Refer to the separate instruction manual for the connection method.

Design

Caution

1. System configuration

- The IN port of the booster regulator has a metallic mesh to prevent dust from entering the booster regulator. However, it cannot remove dust continuously or separate drainage. Make sure to install a mist separator (AM series) at the inlet side of the booster regulator.
- The booster regulator has a sliding part inside, and it generates dust. Also, install a cleaning device such as an air filter or a mist separator on the outlet side as necessary.
- Connect a lubricator to the outlet side, because the accumulated oil in the booster regulator may result in a malfunction.

2. Exhaust air measures

- Provide a dedicated pipe to release the exhaust air from each booster regulator. If exhaust air is converged into a pipe, the back pressure that is created could cause improper operation.
- Depending on the necessity, install a silencer or an exhaust cleaner on the exhaust port of the booster regulator to reduce the exhausting sound.

3. Maintenance space

- Allow the sufficient space for maintenance and inspection.

Series VBA

VBA10A

Flow Characteristics

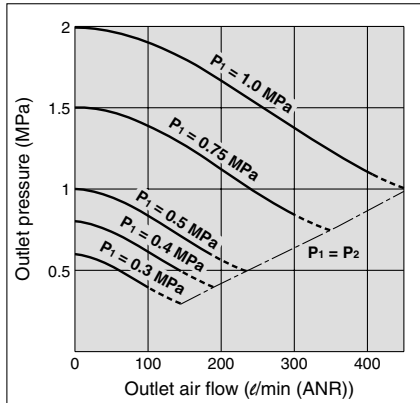

Pressure Characteristics

Inlet pressure: 0.7 MPa
Outlet pressure: 1.0 MPa
Flow rate: 20 l/min (ANR)

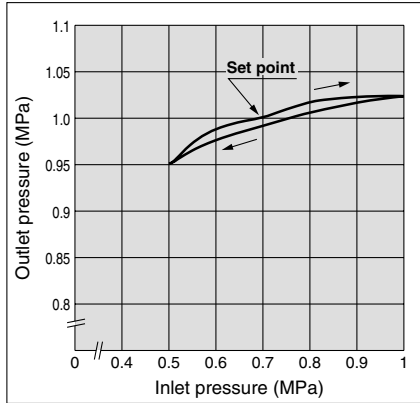

Charge Characteristics

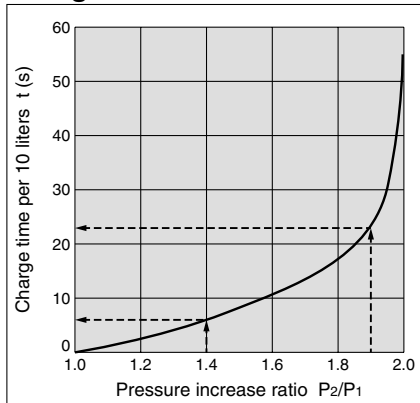

VBA10A

- The time required to charge the tank pressure from 0.7 MPa to 0.95 MPa at 0.5 MPa supply pressure:

$$\frac{P_2}{P_1} = \frac{0.7}{0.5} = 1.4 \quad \frac{P_2}{P_1} = \frac{0.95}{0.5} = 1.9$$

With the pressure increase ratio from 1.4 to 1.9, the charge time of 23 - 6 = 17 sec. (t) is given by the graph. Then, the charge time (T) for a 10 l tank:

$$T = t \times \frac{V}{10} = 17 \times \frac{10}{10} = 17 \text{ (s)}$$

VBA20A, 22A

Flow Characteristics

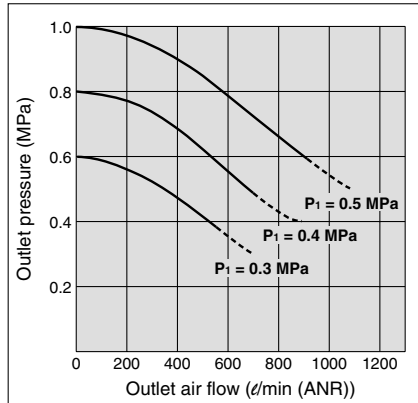

Pressure Characteristics

Inlet pressure: 0.7 MPa
Outlet pressure: 1.0 MPa
Flow rate: 20 l/min (ANR)

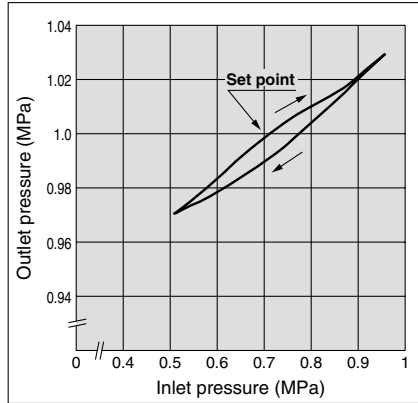

Charge Characteristics

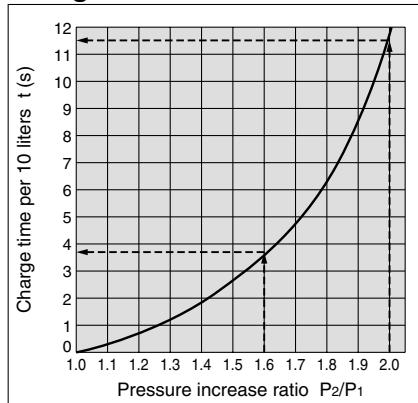

VBA20A, 22A

- The time required to charge the tank pressure from 0.8 MPa to 1.0 MPa at 0.5 MPa supply pressure:

$$\frac{P_2}{P_1} = \frac{0.8}{0.5} = 1.6 \quad \frac{P_2}{P_1} = \frac{1.0}{0.5} = 2.0$$

With the pressure increase ratio from 1.6 to 2.0, the charge time of 11.5 - 3.8 = 7.7 sec. (t) is given by the graph. Then, the charge time (T) for a 100 l tank:

$$T = t \times \frac{V}{10} = 7.7 \times \frac{100}{10} = 77 \text{ (s)}$$

VBA40A, 42A

Flow Characteristics

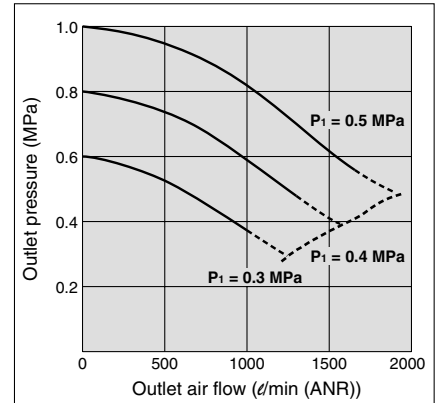

Pressure Characteristics

Inlet pressure: 0.7 MPa
Outlet pressure: 1.0 MPa
Flow rate: 20 l/min (ANR)

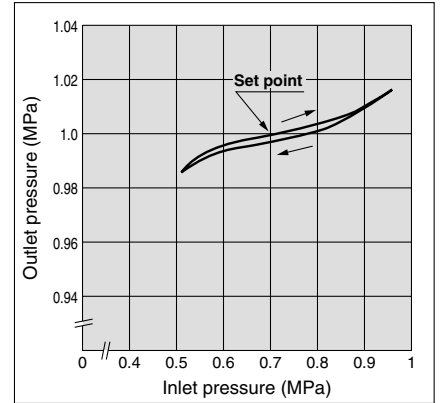

Charge Characteristics

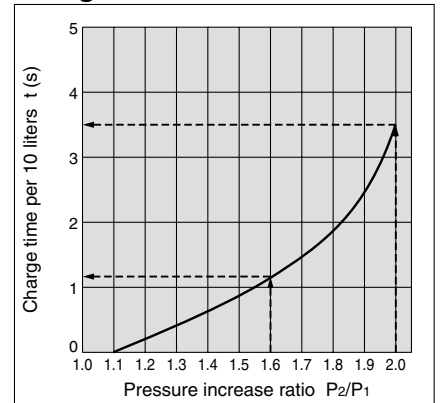

VBA40A, 42A

- The time required to charge the tank pressure from 0.8 MPa to 1.0 MPa at 0.5 MPa supply pressure:

$$\frac{P_2}{P_1} = \frac{0.8}{0.5} = 1.6 \quad \frac{P_2}{P_1} = \frac{1.0}{0.5} = 2.0$$

With the pressure increase ratio from 1.6 to 2.0, the charge time of 3.5 - 1.1 = 2.4 sec. (t) is given by the graph. Then, the charge time (T) for a 100 l tank:

$$T = t \times \frac{V}{10} = 2.4 \times \frac{100}{10} = 24 \text{ (s)}$$

VBA43A

Flow Characteristics

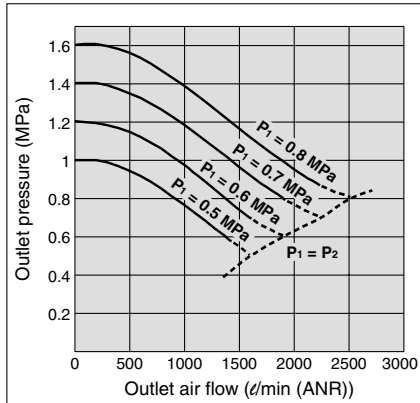

Pressure Characteristics

Inlet pressure: 0.7 MPa
 Outlet pressure: 1.0 MPa
 Flow rate: 20 l/min (ANR)

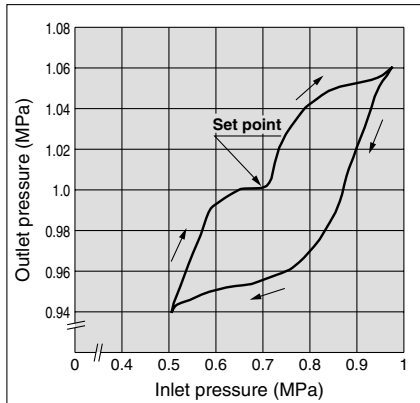

Charge Characteristics

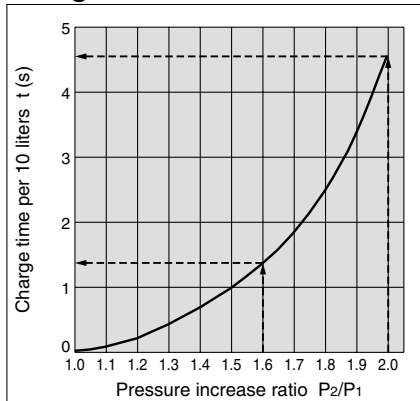

VBA43A

- The time required to charge the tank pressure from 0.8 MPa to 1.0 MPa at 0.5 MPa supply pressure:

$$\frac{P_2}{P_1} = \frac{0.8}{0.5} = 1.6 \quad \frac{P_2}{P_1} = \frac{1.0}{0.5} = 2.0$$

With the pressure increase ratio from 1.6 to 2.0, the charge time of 4.5 - 1.3 = 3.2 sec. (t) is given by the graph. Then, the charge time (T) for a 100 l tank:

$$T = t \times \frac{V}{10} = 3.2 \times \frac{100}{10} = 32 \text{ (s).}$$

VBA1111

Flow Characteristics

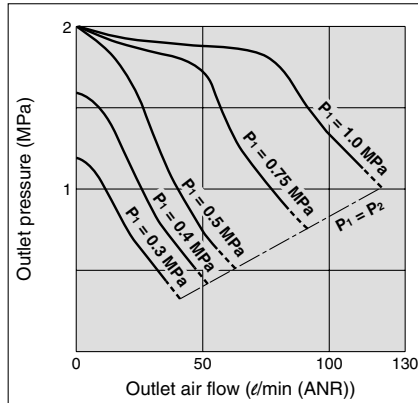

Pressure Characteristics

Inlet pressure: 0.6 MPa
 Outlet pressure: 1.0 MPa
 Flow rate: 10 l/min (ANR)

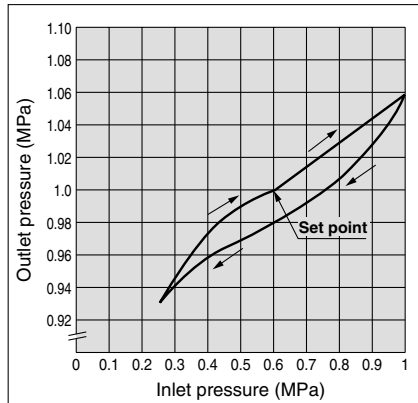

Charge Characteristics

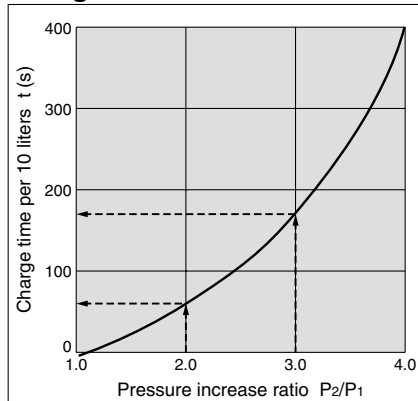

VBA1111

- The time required to charge the tank pressure from 1.0 MPa to 1.5 MPa at 0.5 MPa supply pressure:

$$\frac{P_2}{P_1} = \frac{1.0}{0.5} = 2.0 \quad \frac{P_2}{P_1} = \frac{1.5}{0.5} = 3.0$$

With the pressure increase ratio from 2.0 to 3.0, the charge time of 170 - 60 = 110 sec. (t) is given by the graph. Then, the charge time (T) for a 10 l tank:

$$T = t \times \frac{V}{10} = 110 \times \frac{10}{10} = 110 \text{ (s).}$$

Pulsation/Pulsation is decreased by using the tank.

If the outlet capacity is undersized, pulsation may occur.

VBAT05A

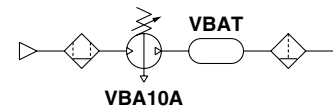
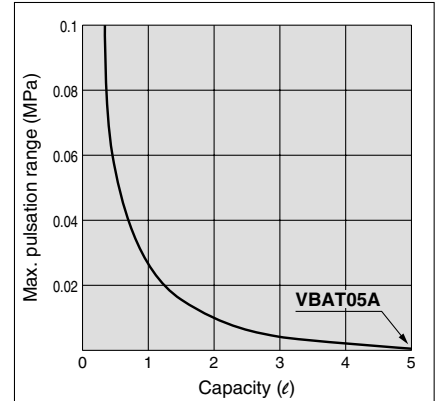

VBAT10A, VBAT20A, VBAT38A

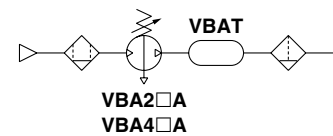
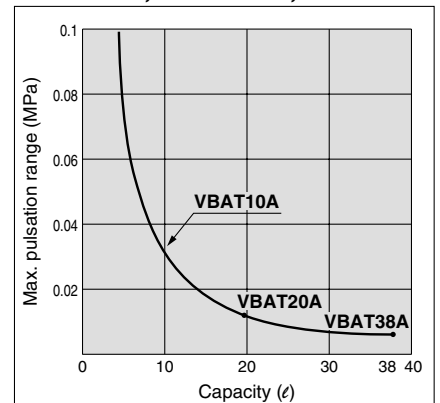

Conditions:
 Inlet pressure: 0.5 MPa
 Outlet set pressure: 1 MPa
 Flow rate: Between 0 and max. flow rate

- Performance of the air tank
 - Alleviates the pulsation generated on the outlet side.
 - Manages supply air to be consumed for short periods of time by storing air through raising the tank pressure.

Series VBA

Working Principle

The **IN** air passes through the check valve to **booster chambers A and B**. Meanwhile, air is supplied to **drive chamber B** via the governor and the switching valve. Then, the air pressure from **drive chamber B** and **booster chamber A** are applied to the piston, boosting the air in **booster chamber B**. As the piston travels, the boosted air is pushed via the check valve to the **OUT** side. When the piston reaches to the end, the piston causes the switching valve to switch, so that **drive chamber B** is in the exhaust state and **drive chamber A** is in the supply state respectively. Then, the piston reverses its movement, this time, the pressures from **booster chamber B** and **drive chamber A** boosts the air in **booster chamber A** and sends it to the **OUT** side. The process described above is repeated to continuously supply highly pressurized air from the **IN** to the **OUT** side. The governor establishes the outlet pressure by handle operation and pressure adjustment in the drive chamber by feeding back the outlet pressure.

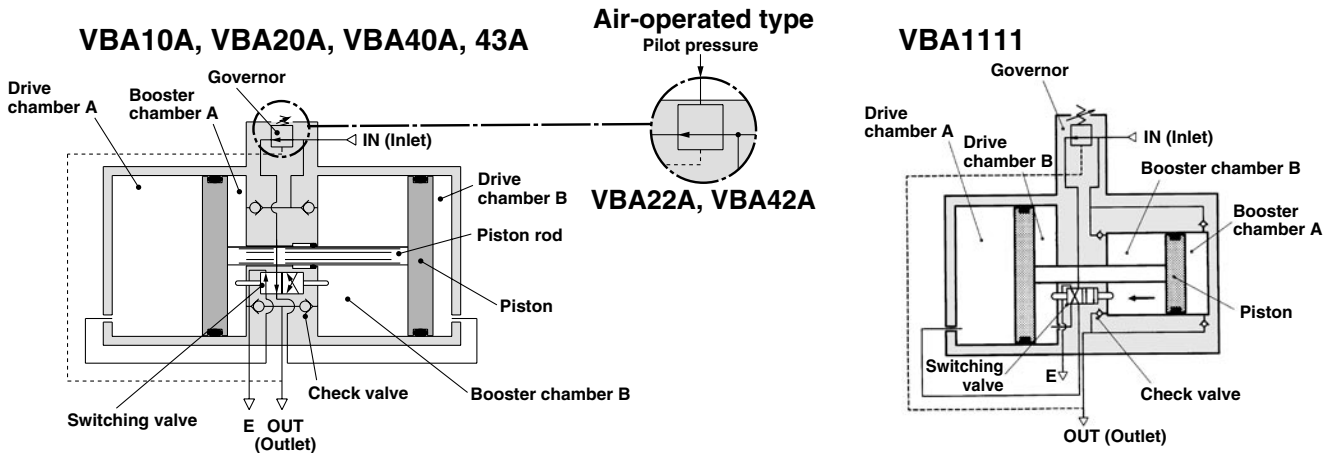

Circuit Example

- When only some of the machines in the plant require high-pressure air, booster regulators can be installed for only the equipment that requires it. This allows the overall system to use low air pressure while accommodating machines requiring high-pressure air.

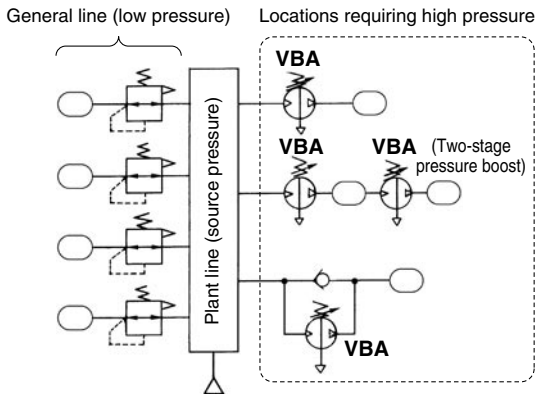

- When filling a tank or the like from a source at atmospheric pressure, a circuit with a check valve can be used to reduce the filling time by allowing air to pass through the check valve up to the inlet pressure.

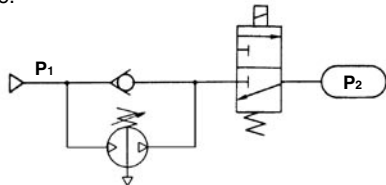

Initially, inlet pressure (P_1) passes through the check valve, fills P_2 , and results in $P_1 = P_2$.

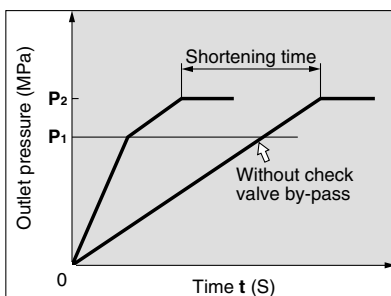

- When the actuator output is insufficient but space limitations prohibit switching to a larger cylinder diameter, a booster regulator can be used to increase the pressure. This makes it possible to boost the output without replacing the actuator.
- When a certain level of output is required but the cylinder size must be kept small so that the driver remains compact.

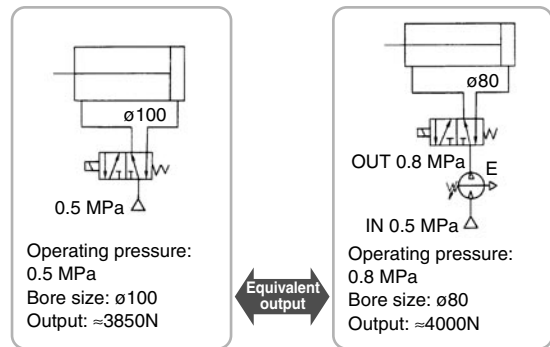

- When only one side of the cylinder is used for work, booster regulators can be installed only on the lines that require them to reduce the overall air consumption volume.

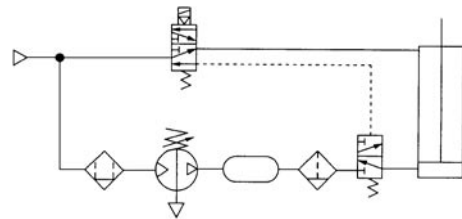

Sizing (Sizing can be achieved by using SMC Pneumatic System Energy Saving Program Ver. 3.1. Please contact your SMC sales representative.)

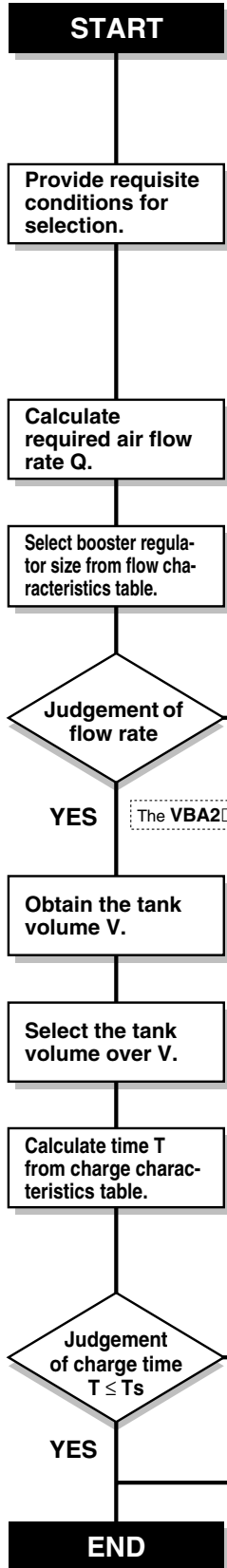
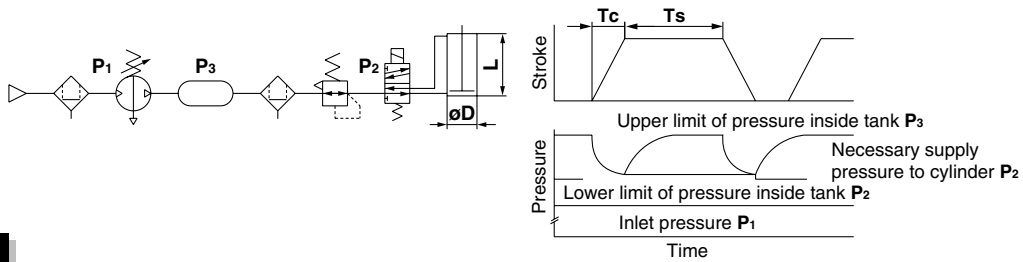

Necessary conditions:
D [mm]: Cylinder bore size
L [mm]: Cylinder stroke
W [mm/s]: Cylinder operating speed
C [pc.]: Number of cylinders
Tc [s]: Cylinder operating time
Ts [s]: Cylinder stop time
P1 [MPa]: Inlet pressure
P2 [MPa] ^{Note 1)}: Necessary supply pressure to cylinder

Example:

D	100
L	100
W	200
C	1
Tc	0.5
Ts	30
P1	0.5
P2	0.8

Other conditions:
Q [ℓ/min (ANR)]: Required air flow rate
Qb [ℓ/min (ANR)]: Outlet air flow rate of booster regulator
Tc [s]: Cylinder stroke time
K: Cylinder double-acting: 2, single-acting: 1
P3 [MPa] ^{Note 2)}: Tank charge pressure
T1 [s]: Time to charge (Time to charge to P2)
T2 [s]: Time to charge (Time to charge to P3)
T [s]: Time to charge (Time to charge from P2 to P3)
Z: Number of booster regulators

Note 1) P2 is the necessary supply pressure to a cylinder, and set the pressure below the lower limit of pressure inside the tank with a regulator. Adjust the pressure taking the maximum operating pressure of equipment in use into consideration.
 Note 2) P3 is the output pressure of the booster regulator, which is also the upper limit of charge pressure to a tank.

$$Q \text{ [ℓ/min (ANR)]} = \frac{\pi \times D^2 \times W}{4 \times 10^6} \times \frac{(P_2 + 0.101)}{0.101} \times 60 \times C$$

$$Q = \frac{\pi \times 100^2 \times 200}{4 \times 10^6} \times \frac{(0.8 + 0.101)}{0.101} \times 60 \times 1 = 841 \text{ [ℓ/min (ANR)]}$$

VBA2□A: Qb = 600 [ℓ/min (ANR)]
VBA4□A: Qb = 1050 [ℓ/min (ANR)]
 Refer to "Flow Characteristics" on pages 3 and 4.

⚠ Caution

- Use the VBA1111 (pressure increase ratio 4) with pressure increase ratio of 2 to 4. Usage of pressure increase ratio below 2 is preferred for the VBA10A (pressure increase ratio 2). A stable operation and increased life expectancy will result.
- Inlet supply pressure volume is approximately twice the volume of the outlet side. {approx. 2 times (pressure increase ratio 2), approx. 4 times (pressure increase ratio 4)}. Booster regulator requires that the inlet side volume should be the sum of the flow volume running into the outlet side and the volume exhausted from E port (for driving), because air is the power source.

NO: Need no tank The VBA4□A can supply necessary pressure.

YES: The VBA2□A cannot obtain necessary pressure.

$$V \text{ [ℓ]} = \frac{(Q - Qb/2) \times (Tc \times K/60)}{(P_3 - P_2) \times 9.9}$$

$$V = \frac{(841 - 600/2) \times (0.5 \times 2/60)}{(1.0 - 0.8) \times 9.9} = 4.6 \text{ [ℓ]}$$

Select the **VBAT10A**, which can be directly connected to the **VBA2□A**.

Refer to "Charge Characteristics" on pages 3 and 4.

$$T \text{ [s]} = \left(\frac{V}{10}\right) \times \frac{T_2 - T_1}{Z}$$

$$T = \left(\frac{4.6}{10}\right) \times \frac{11.5 - 3.8}{1} = 3.5 \text{ [s]}$$

NO: Extend stop time Ts up to charge time T or more.

YES: Increase number of booster regulators (Z) to decrease T.

NO: Avoid pulsation (Max. 0.05 MPa)

YES: Select the tank from table below.

Tank part no.	Inner volume	Applicable combination model		
VBAT05A	5 ℓ	VBA10A	—	—
VBAT10A	10 ℓ	VBA10A	VBA2□A	—
VBAT20A	20 ℓ	—	VBA2□A	VBA4□A
VBAT38A	38 ℓ	—	VBA2□A	VBA4□A

When running continuously for longer periods of time, confirm the life expectancy. When the life expectancy is shorter than required, select a larger sized booster regulator.

Design

⚠ Warning

- Warning concerning abnormal outlet pressure**
 - If there is a likelihood of causing an outlet pressure drop due to unforeseen circumstances such as equipment malfunction, thus leading to a major problem, take safety measures on the system side.
 - Because the outlet pressure could exceed its set range if there is a large fluctuation in the inlet pressure, leading to unexpected accidents, take safety measures against abnormal pressures.
 - Operate the equipment within its maximum operating pressure and set pressure range.
- Residual pressure measures**
 - Connect a 3-port valve to the OUT side of the booster regulator if the residual pressure must be released quickly from the outlet pressure side for maintenance, etc. (Refer to the below diagram.) The residual outlet pressure side cannot be released even if the 3-port valve is connected to the IN side because the check valve in the booster regulator will activate.

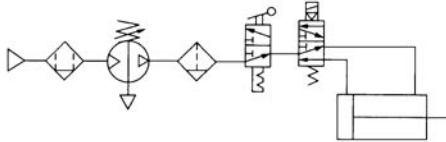

- After operation is finished, release the supply pressure at the inlet. This stops the booster valve from moving needlessly and prevents operating malfunctions.

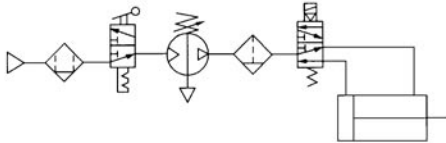

Selection

⚠ Caution

- Verify the specifications.**
 - Consider the operating conditions and operate this product within the specification range that is described in this catalogue.
- Selection**
 - Based on the conditions (pressure, flow rate, takt time, etc.) required for the outlet side of the booster regulator, select the size of the booster regulator in accordance with the selection procedures described in this catalogue or model selection program.
 - Use the VBA1111 (pressure increase ratio 4) with pressure increase ratio of 2 to 4. Usage of pressure increase ratio below 2 is preferred for the VBA10A (pressure increase ratio 2). A stable operation and increased life expectancy will result.
 - Inlet supply pressure volume is approximately twice the volume of the outlet side. {approx. 2 times (pressure increase ratio 2), approx. 4 times (pressure increase ratio 4)}. Booster regulator requires that the inlet side volume should be the sum of the flow volume running into the outlet side and the volume exhausted from E port (for driving), because air is the power source.
 - When running continuously for longer periods of time, confirm the life expectancy. The life expectancy of a booster regulator is dependent upon the operational cycle. Thus, when used for driving cylinders, etc. in the outlet side, life expectancy will be reduced.
 - Make sure the outlet pressure is set more than 0.1 MPa higher than the inlet pressure. A pressure difference less than 0.1 MPa makes the operation unstable and may result in malfunction.

Mounting

⚠ Caution

- Transporting**
 - When transporting this product, hold it lengthwise with both hands. Never hold it by the black handle that protrudes from the centre because the handle could become detached from the body, causing the body to fall and leading to injury.
- Installation**
 - Install this product so that the silver-coloured tie-rods and cover are placed horizontally. If mounted vertically, it may result in malfunction.
 - Because the piston cycle vibration is transferred, use the following mounting bolts (VBA1: M5; VBA2,4: M10) and tighten them with the specified torque (VBA1: 3 N·m; VBA2, 4: 24 N·m).
 - If the transmission of vibration is not preferred, insert an isolating rubber material before installation.
 - The pressure gauge should be mounted with the following torque. R 1/16: 3 to 4 N, R 1/8: 7 to 9 N

Piping

⚠ Caution

- Flushing**
 - Use an air blower to flush the piping to thoroughly remove any cutting chips, cutting oil, or debris from the piping inside, before connecting them. If they enter the inside of the booster regulator, they could cause the booster regulator to malfunction or its durability could be affected.
- Piping size**
 - To bring the booster regulator's ability into full play, make sure to match the piping size to the port size.

Air Supply

⚠ Caution

- Quality of air source**
 - Connect a mist separator to the inlet side near the booster regulator. If the quality of the compressed air is not thoroughly controlled, the booster regulator could malfunction (without being able to boost) or its durability could be affected.
 - If dry air (atmospheric pressure dew point: -17°C or less) is used, the life expectancy may be shortened because dry air will accelerate evaporation of grease inside.

Operating Environment

⚠ Caution

- Installation location**
 - Do not install this product in an area that is exposed to rain-water or direct sunlight.
 - Do not install in locations influenced by vibrations. If it must be used in such an area due to unavoidable circumstances, please contact SMC beforehand.

Handling

⚠ Caution

1. Setting the pressure on the handle-operated type

- If air is supplied to the product in the shipped state, the air will be released.
Set the pressure by quickly pulling up on the governor handle, releasing the lock, and rotating the handle in the direction of the arrow (+).
- There is an upper and lower limit for the handle rotation. If over-rotating the handle even after reaching to the limit, the internal parts may be damaged. If the handle suddenly feels heavy while being turned, stop turning the handle.
- Once the setting is completed, push the handle down and lock it.
- To decrease the outlet pressure, after the pressure has been set, rotate the handle in the direction of the arrow (-). The residual air will be released from the area of the handle, due to the relief construction of the governor.
- To reset the pressure, first reduce the pressure so that it is lower than the desired pressure; then, set it to the desired pressure.

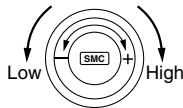

2. Setting the pressure on the air-operated type (VBA22A, 42A)

- Connect the outlet pipe of the pilot regulator for the remote control to the pilot port (P). (Refer to the figure below.)
- Refer to the following figure for the relation between the pilot pressure and outlet pressure.
- The AR20 and AW20 are recommended for the pilot regulator.

Pilot regulator

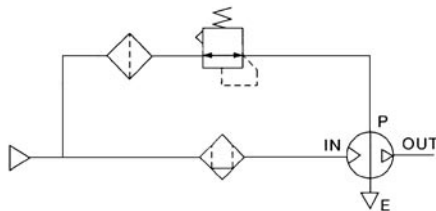

- The outlet pressure is twice the pilot pressure.
- When the inlet pressure is 0.4 MPa:

Pilot pressure
0.2 MPa to 0.4 MPa
Outlet pressure
0.4 MPa to 0.8 MPa

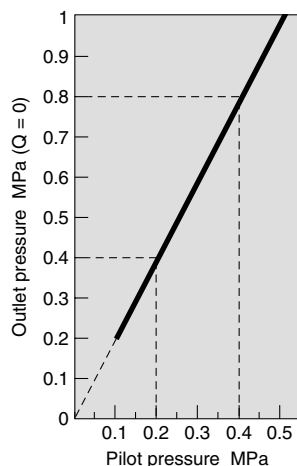

3. Draining

- If this product is used with a large amount of drainage accumulated in the filter, mist separator, or the tank, the drainage could flow out, leading to equipment malfunction. Therefore, drain the system once a day. If it is equipped with an auto-drain, check its operation once a day.

4. Exhaust

- Exhausting time from E port may be longer for a booster regulator which is set to switch in longer hour intervals. This is not an abnormal phenomenon.

5. Maintenance

- Life expectancy varies depending on the quality of air and the operating conditions. Signs that the unit is reaching the end of its service life include the following:
 - Constant bleed from under the handle.
 - Air exhaust can be heard from the booster regulator at 10 to 20 second intervals even when there is no air consumption on the outlet side.
 Conduct maintenance earlier than scheduled in such cases.
- When maintenance is required, confirm the model and serial number of the booster regulator, and please contact SMC for maintenance kit.
- Maintenance should be carried out according to the specified maintenance procedure by individuals possessing enough knowledge and experiences in maintaining pneumatic equipment.
- The list of replacement parts and kit part number are shown on page 9, and the figure shows the position of the parts.

Series VBA

Construction/Replacement Parts

VBA10A

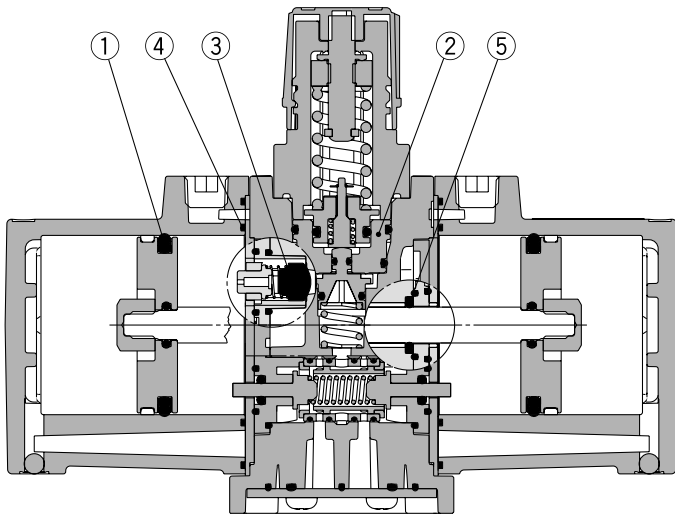

VBA20A, 22A, VBA40A, 42A, 43A

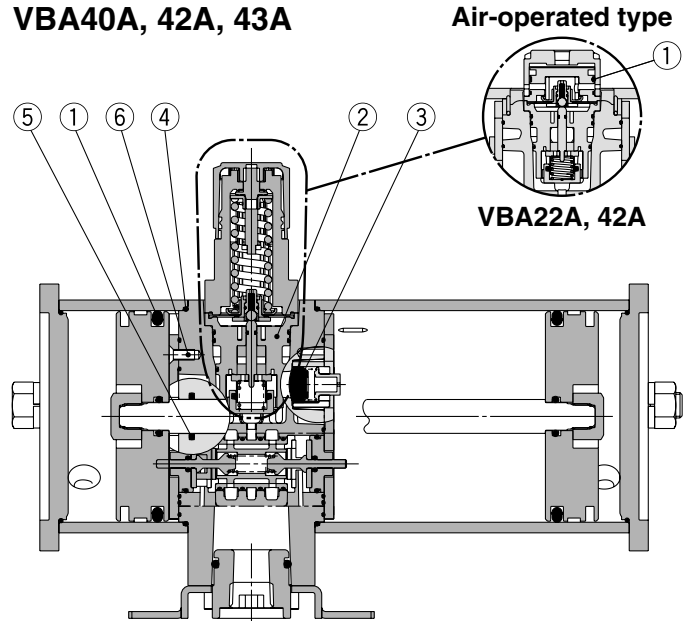

VBA1111

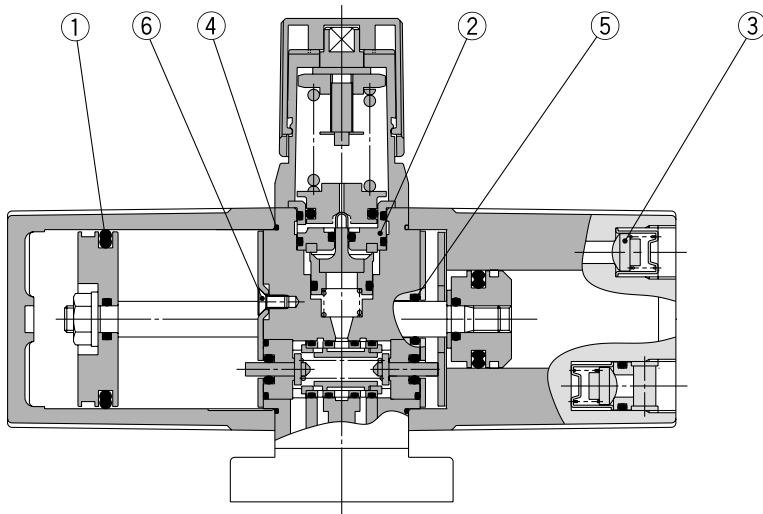

Replacement Parts/Kit Part No.

Place an order with the following applicable kit part number.

Model	VBA10A	VBA20A	VBA40A	VBA22A	VBA42A	VBA43A	VBA1111
Kit part no.	KT-VBA10A-1	KT-VBA20A-1	KT-VBA40A-1	KT-VBA22A-1	KT-VBA42A-1	KT-VBA43A-1	KT-VBA1111-2

The kit includes the parts from ① to ⑥ and a grease pack.

No.	Description	Model						
		VBA10A	VBA20A	VBA40A	VBA22A	VBA42A	VBA43A	VBA1111
		Quantity						
1	Piston seal		2		2 large 1 small		2	1 each large and small
2	Governor assembly				1			
3	Check valve				4			
4	Gasket				2			
5	Rod seal				1			
6	Mounting screw	—	8	12	8	12		8
—	Grease pack	1		2	1	2		1

* The grease pack has 10 g of grease.

* Make sure to refer to the procedure for maintenance.

Dimensions

VBA10A-02

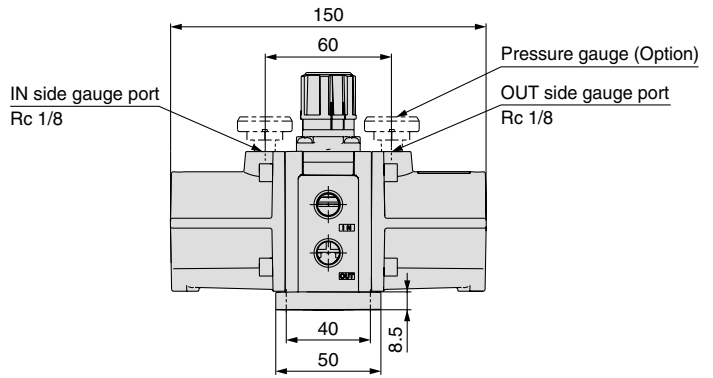
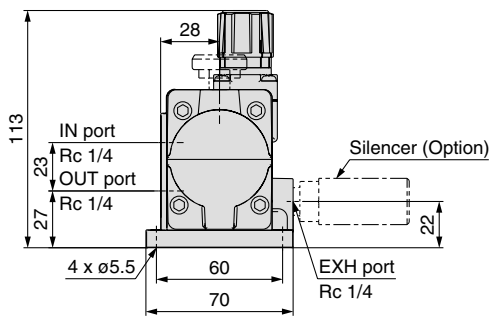

VBA20A-03

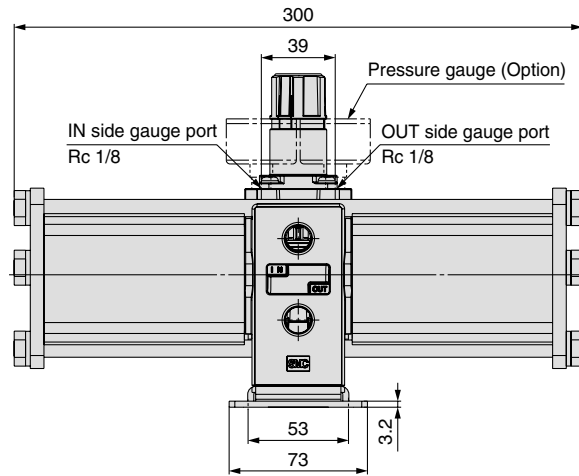
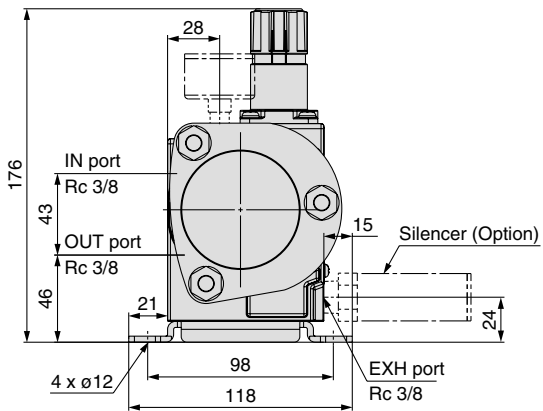

VBA40A-04

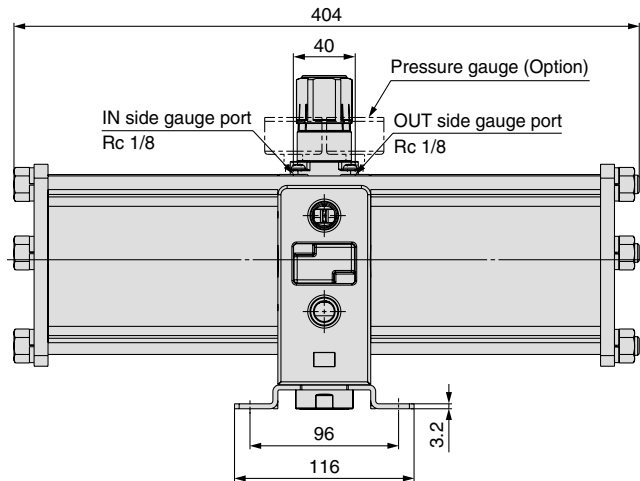
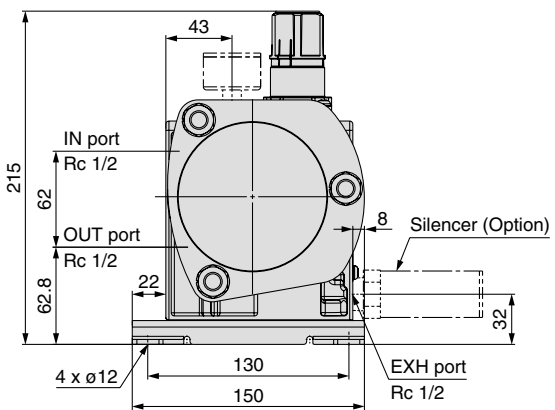

VBA1111-02

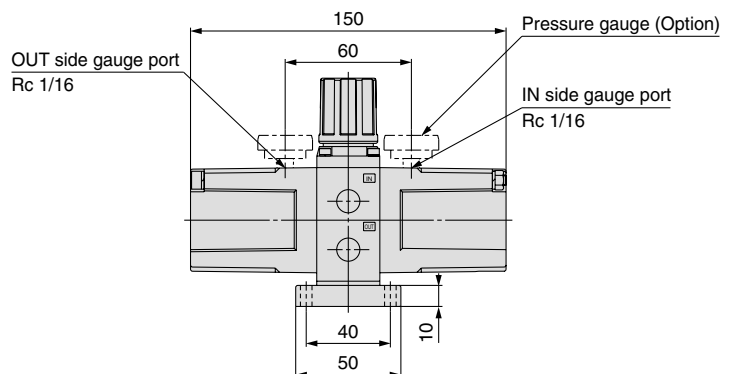
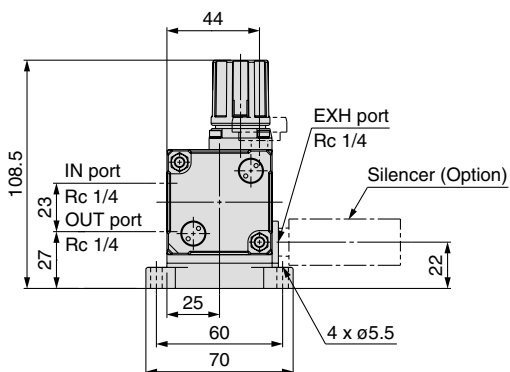

Series VBA

Dimensions

VBA22A-03

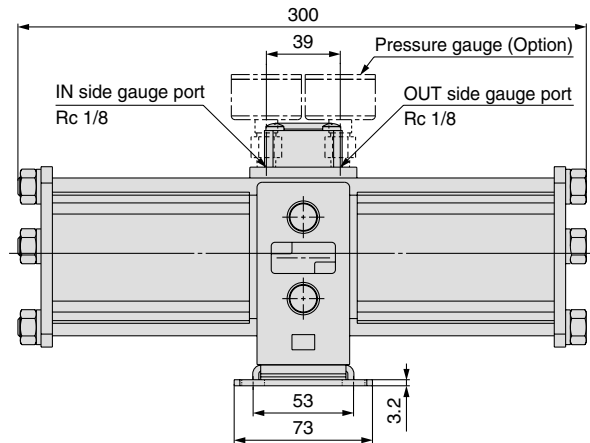
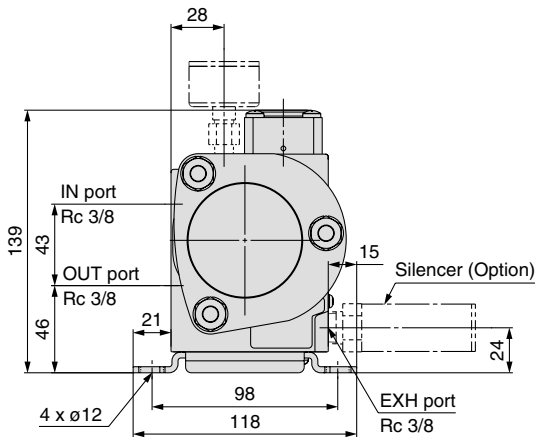

VBA42A-04

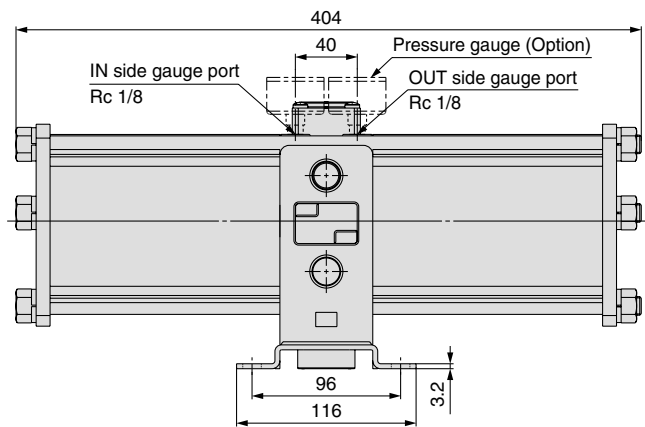
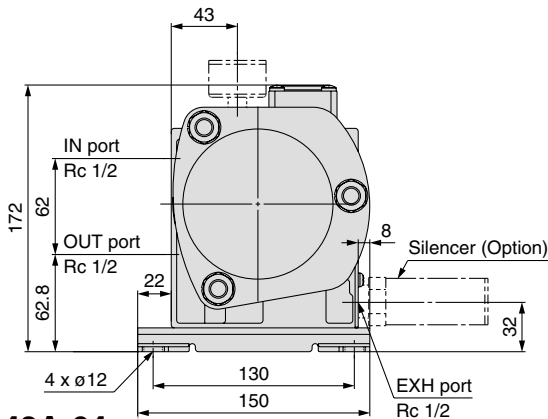

VBA43A-04

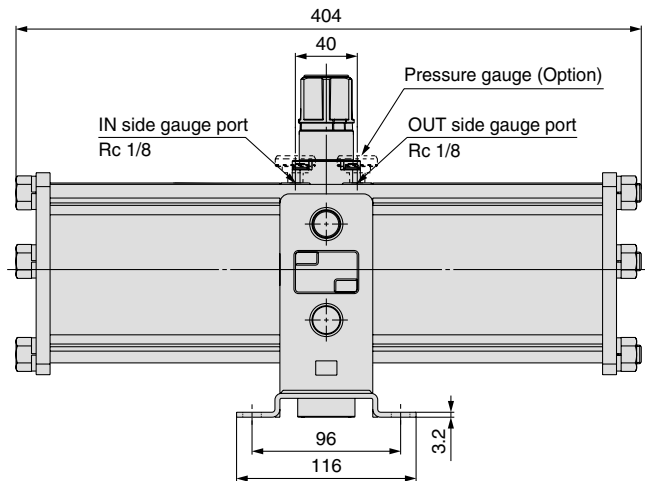
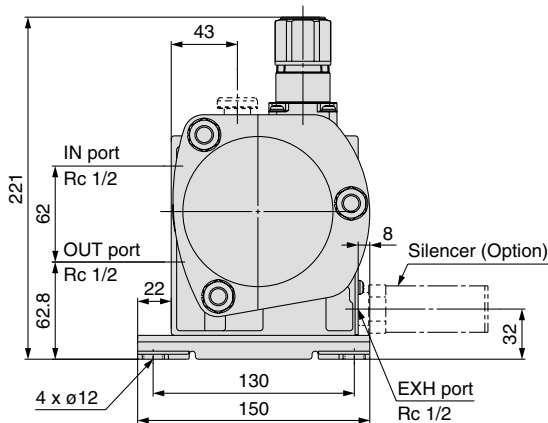

Made to Order



Please contact SMC for detailed dimensions, specifications, and lead times.

1 Copper-free/Fluorine-free

The inner or outer copper parts material has been changed to stainless steel or aluminum. The fluorine resin parts has been changed to general resin.

20 — Standard model no.

● Made to Order
Copper-free/Fluorine-free

- * Inquire about booster regulator with pressure gauge.
- * This option cannot be selected for air tank with safety valve.

2 CE explosion-proof directive (ATEX) compliant

56 — Standard model no.

● Made to Order
CE explosion-proof directive (ATEX): Category 3GD

3 Ozone resistant

Ozone resistance is strengthened through the use of fluororubber (diaphragm) and hydrogenated NBR (valve, rod seal) for the rubber parts of the seal material.

80 — Standard model no.

● Made to Order
Ozone resistant

- * Weather resistant NBR (diaphragm) and hydrogenated NBR (valve) is used for the rubber parts of standard products.

Air Tank

Series VBAT



How to Order



Made to Order

(For details, refer to page 11.)

VBAT 10 A [] - S V - Q

Tank inner volume

Symbol	Inner volume
05	5 ℓ
10	10 ℓ
20	20 ℓ
38	38 ℓ

Material

Symbol	Material
A	Carbon steel (SS400)

Thread type

Symbol	Thread type
—	Rc
F	G

- Compact connections are possible with booster regulators.
- It can be used alone as a tank.
- Also compatible with CE standards

Option

Symbol	Option
V	Drain valve

CE compatible product

Symbol	Standards
Q	CE marking

Note) Applicable product self-declaration document attached.

Option

Symbol	Option	Applicable model
—	None	All models
R	Safety valve ^{Note 1)} ^{Note 2)} (Set pressure 1 MPa)	VBAT20A VBAT38A
S	Safety valve ^{Note 1)} ^{Note 2)} (Set pressure 2 MPa)	VBAT05A VBAT10A

Note 1) The safety valve is not applicable for copper-free, fluorine-free specification (20-).

Note 2) A safety valve port is provided only when option R or S is selected.



VBAT05A



VBAT38A

Model (Carbon Steel)

Model	VBAT05A	VBAT10A	VBAT20A	VBAT38A
Fluid	Compressed air			
Tank capacity (ℓ)	5	10	20	38
Max. operating pressure (MPa)	2.0		1.0	
IN port size (Rc)	3/8	3/8	1/2	1/2
OUT port size (Rc)	3/8	1/2	1/2	3/4
Ambient and fluid temperature (°C)	0 to 75			
Weight (kg)	6.6	10.0	14.0	21.0
Material	Carbon steel			
Paint	Outside: Silver paint, Inside: Rustproof paint			

* Accessories and options are included in the same container.

Series VBAT

List of Air Tank for Overseas

The pressure vessel law is different from country to country, so an air tank suitable to a country needs to be manufactured. Please select from the below table. For details on all products except for CE markings, please contact SMC.

Country/Region	Law	Exportable models	Details
EU	CE Marking Simple Pressure Vessels Directive	VBAT05A-SV-Q, VBAT05AF-SV-Q	Applicable product Self-declaration document attached (The G-thread type is 6 mm longer due to plug type differences.)
		VBAT10A-SV-Q, VBAT10AF-SV-Q	
		VBAT20A-RV-Q, VBAT20AF-RV-Q	
		VBAT38A-RV-Q, VBAT38AF-RV-Q	

VBAT□A (Carbon Steel) Accessories/Part No.

Model	VBAT05A	VBAT10A	VBAT20A	VBAT38A
Accessory kit	VBAT5A-Y-3	VBAT10A-Y-3	VBAT20A-Y-3	
Safety valve	VBAT-S (Set pressure 2 MPa)		VBAT-R (Set pressure 1 MPa)	
Drain valve	VBAT-V1			

Note 1) The set pressure of the safety valve cannot be changed.

Note 2) The safety valve is a safety measure that protects the tank from excess pressure. The valve opens automatically when the specified pressure is reached, releasing excess pressure inside the tank. The valve closes again when the pressure drops below a designated value. Select a pressure valve appropriate for the maximum operating pressure specification of the tank.

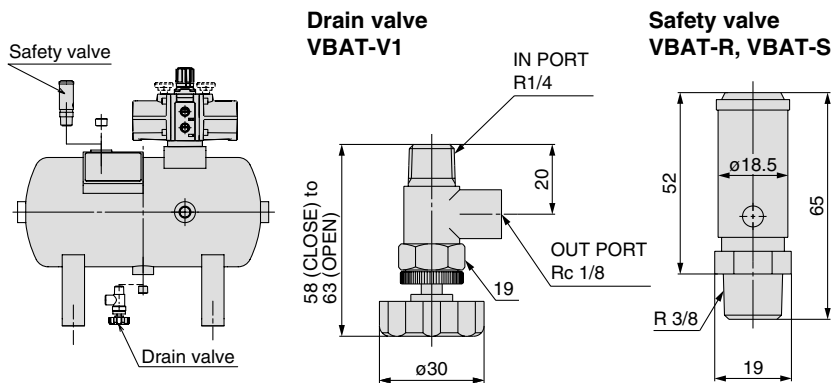

Design

Warning

1. Operating pressure

- Operate this product at or below the maximum operating pressure. If it is necessary, take appropriate safety measures to ensure that the maximum operating pressure is not exceeded.
- When the tank alone is used**
Use a pressure switch or a safety valve to make sure that the maximum operating pressure is not exceeded.

2. Connection

- Connect a filter or a mist separator to the OUT side of the tank. Because the inner surface of the tank is untreated, there is a possibility of dust flowing out to the outlet side.
- Using tank accessories, a VBA booster regulator can be connected directly in the combinations indicated below.

Air tank		Booster regulator		
		VBA10A VBA1111	VBA2□A	VBA40A VBA42A
		VBAT05A	●	—
VBAT10A	●	●	—	
VBAT20A	—	●	●	
VBAT38A	—	●	●	

Selection

Caution

- Consider the operating conditions and operate this product within the specification range.
- When using the air tank with a booster valve, refer to "Sizing" on page 6 or SMC Pneumatic System Energy Saving Program.

Mounting

Caution

1. Accessories

- See the operating manual (VBAT-M1, VBAT-M2, VBAT-M3, VBAT-M4) regarding combining booster regulators with older model air tanks.
- The accessories are secured by bands to the feet of the tank. Once removed, make sure not to lose them.

2. Installation

- Tank should be installed away from people. It is dangerous if the accumulated air inside the tank were to seep out.
- Do not mount the air tank on a moving part or a place with vibration.
- When connecting a booster regulator with the tank, refer to the operating manual first, which is provided with the air tank before assembling.
- Refer to the operating manual regarding mounting methods when using long bolts.
- To mount the air tank on a floor surface, use the four holes to secure the tank with bolts or anchor bolts.

Maintenance

Warning

1. Inspection

- The use of pressure vessels could lead to an unexpected accident due to external damage or internal corrosion caused by drainage. Therefore, make sure to check periodically for external damage, or the extent of internal corrosion through the port hole. An ultrasonic thickness indicator may also be used to check for any reduction in material thickness.

2. Draining

- If this product is used with a large amount of drainage, the drainage could flow out, leading to equipment malfunction or corrosion inside the tank. Therefore, drain the system once a day.

Dimensions

VBAT05A Material: Carbon steel

Connected to VBA10A, 1111

Booster regulator model	A
VBA10A	370
VBA1111	365.5

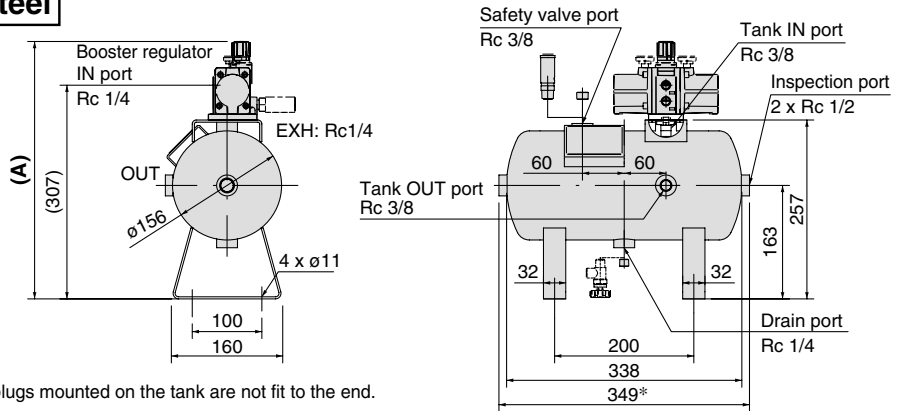

* The length may be longer than the specification if the plugs mounted on the tank are not fit to the end.

VBAT10A Material: Carbon steel

Connected to VBA10A, 1111

Booster regulator model	A
VBA10A	391
VBA1111	386.5

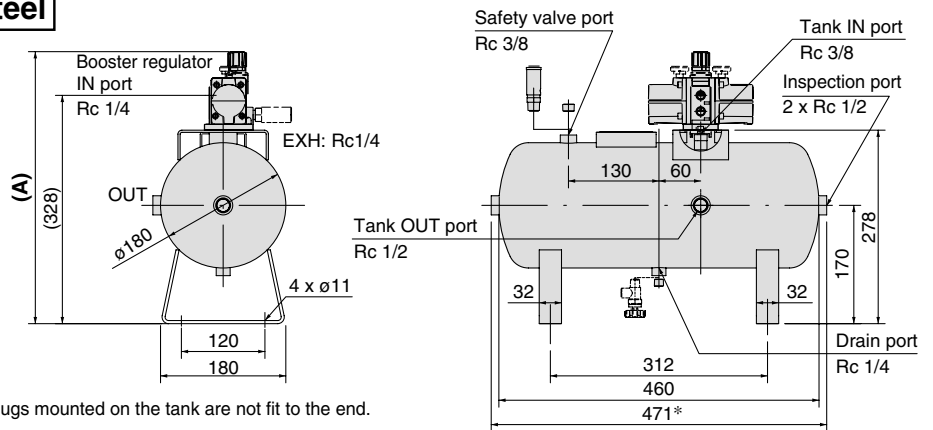

* The length may be longer than the specification if the plugs mounted on the tank are not fit to the end.

Connected to VBA20A

Connected to VBA22A

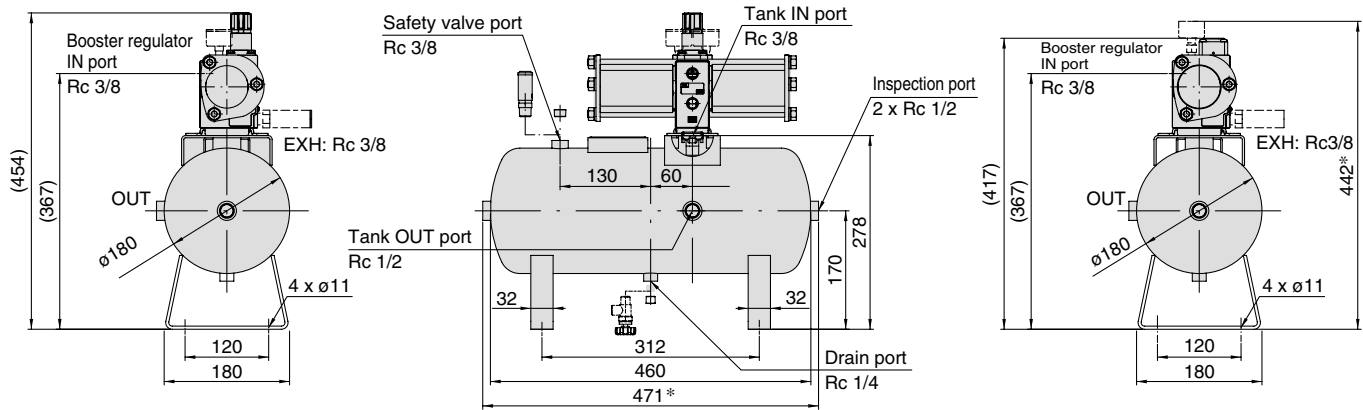

* The length may be longer than the specification if the plugs mounted on the tank are not fit to the end.

Series VBAT

Dimensions

VBAT20A Material: Carbon steel

Connected to VBA20A, 40A

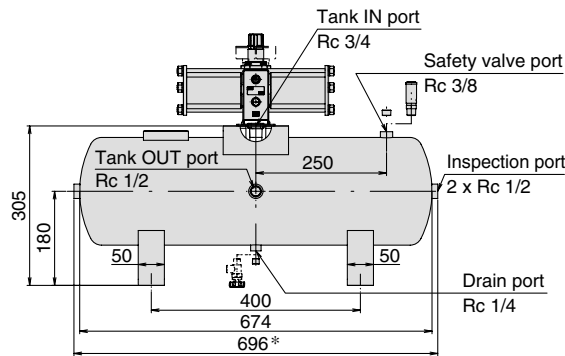
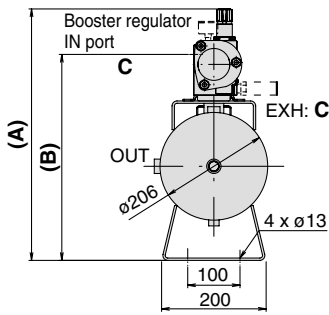

Connected to VBA22A, 42A

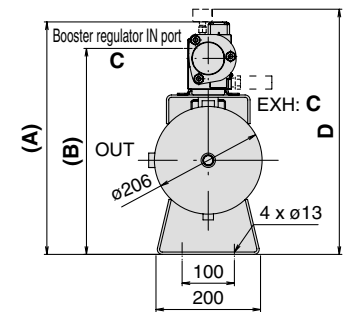

* The length may be longer than the specification if the plugs mounted on the tank are not fit to the end.

Booster regulator model	A	B	C	D (Note)
VBA20A	481	394	Rc 3/8	—
VBA40A	520	429.8	Rc 1/2	—
VBA22A	444	394	Rc 3/8	469
VBA42A	477	429.8	Rc 1/2	493

Note) Option: when G (pressure gauge) is selected

VBAT38A Material: Carbon steel

Connected to VBA20A, 40A

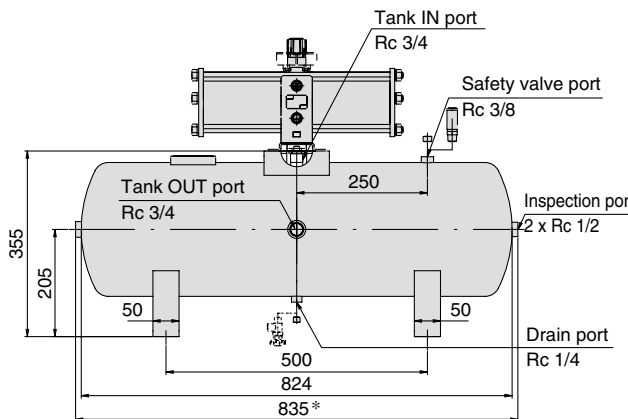
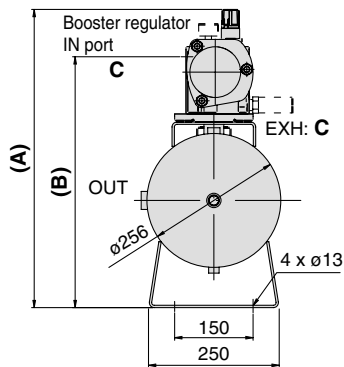

Connected to VBA22A, 42A

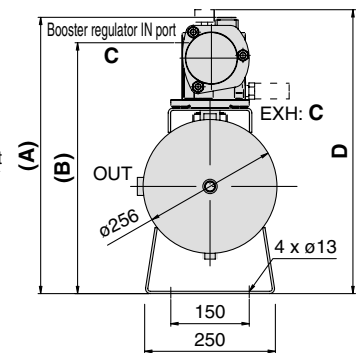

* The length may be longer than the specification if the plugs mounted on the tank are not fit to the end.

Booster regulator model	A	B	C	D (Note)
VBA20A	531	444	Rc 3/8	—
VBA40A	570	479.8	Rc 1/2	—
VBA22A	494	444	Rc 3/8	519
VBA42A	527	479.8	Rc 1/2	543

Note) Option: when G (pressure gauge) is selected

VBAT⁰⁵₁₀A1-R

With safety valve

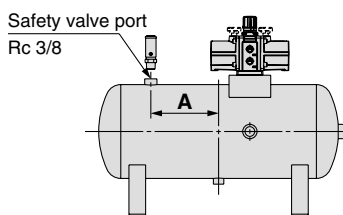

Tank model	A (mm)
VBAT05	60
VBAT10	130

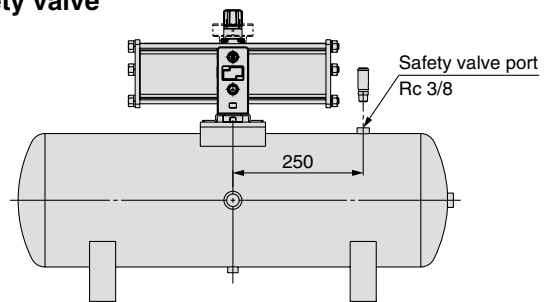

VBAT²⁰₃₈A1-R

With safety valve



Safety Instructions

These safety instructions are intended to prevent hazardous situations and/or equipment damage. These instructions indicate the level of potential hazard with the labels of “**Caution**,” “**Warning**” or “**Danger**.” They are all important notes for safety and must be followed in addition to International Standards (ISO/IEC)*1, and other safety regulations.

-  **Caution:** **Caution** indicates a hazard with a low level of risk which, if not avoided, could result in minor or moderate injury.
-  **Warning:** **Warning** indicates a hazard with a medium level of risk which, if not avoided, could result in death or serious injury.
-  **Danger:** **Danger** indicates a hazard with a high level of risk which, if not avoided, will result in death or serious injury.

- *1) ISO 4414: Pneumatic fluid power – General rules relating to systems.
- ISO 4413: Hydraulic fluid power – General rules relating to systems.
- IEC 60204-1: Safety of machinery – Electrical equipment of machines. (Part 1: General requirements)
- ISO 10218-1: Manipulating industrial robots - Safety. etc.

Warning

- 1. The compatibility of the product is the responsibility of the person who designs the equipment or decides its specifications.**
Since the product specified here is used under various operating conditions, its compatibility with specific equipment must be decided by the person who designs the equipment or decides its specifications based on necessary analysis and test results. The expected performance and safety assurance of the equipment will be the responsibility of the person who has determined its compatibility with the product. This person should also continuously review all specifications of the product referring to its latest catalogue information, with a view to giving due consideration to any possibility of equipment failure when configuring the equipment.
- 2. Only personnel with appropriate training should operate machinery and equipment.**
The product specified here may become unsafe if handled incorrectly. The assembly, operation and maintenance of machines or equipment including our products must be performed by an operator who is appropriately trained and experienced.
- 3. Do not service or attempt to remove product and machinery/equipment until safety is confirmed.**
 1. The inspection and maintenance of machinery/equipment should only be performed after measures to prevent falling or runaway of the driven objects have been confirmed.
 2. When the product is to be removed, confirm that the safety measures as mentioned above are implemented and the power from any appropriate source is cut, and read and understand the specific product precautions of all relevant products carefully.
 3. Before machinery/equipment is restarted, take measures to prevent unexpected operation and malfunction.
- 4. Contact SMC beforehand and take special consideration of safety measures if the product is to be used in any of the following conditions.**
 1. Conditions and environments outside of the given specifications, or use outdoors or in a place exposed to direct sunlight.
 2. Installation on equipment in conjunction with atomic energy, railways, air navigation, space, shipping, vehicles, military, medical treatment, combustion and recreation, or equipment in contact with food and beverages, emergency stop circuits, clutch and brake circuits in press applications, safety equipment or other applications unsuitable for the standard specifications described in the product catalogue.
 3. An application which could have negative effects on people, property, or animals requiring special safety analysis.
 4. Use in an interlock circuit, which requires the provision of double interlock for possible failure by using a mechanical protective function, and periodical checks to confirm proper operation.

Caution

- 1. The product is provided for use in manufacturing industries.**
The product herein described is basically provided for peaceful use in manufacturing industries.
If considering using the product in other industries, consult SMC beforehand and exchange specifications or a contract if necessary.
If anything is unclear, contact your nearest sales branch.

Limited warranty and Disclaimer/ Compliance Requirements

The product used is subject to the following “Limited warranty and Disclaimer” and “Compliance Requirements”.
Read and accept them before using the product.

Limited warranty and Disclaimer

1. The warranty period of the product is 1 year in service or 1.5 years after the product is delivered.*2)
Also, the product may have specified durability, running distance or replacement parts. Please consult your nearest sales branch.
2. For any failure or damage reported within the warranty period which is clearly our responsibility, a replacement product or necessary parts will be provided.
This limited warranty applies only to our product independently, and not to any other damage incurred due to the failure of the product.
3. Prior to using SMC products, please read and understand the warranty terms and disclaimers noted in the specified catalogue for the particular products.

*2) Vacuum pads are excluded from this 1 year warranty.

A vacuum pad is a consumable part, so it is warranted for a year after it is delivered. Also, even within the warranty period, the wear of a product due to the use of the vacuum pad or failure due to the deterioration of rubber material are not covered by the limited warranty.

Compliance Requirements

1. The use of SMC products with production equipment for the manufacture of weapons of mass destruction (WMD) or any other weapon is strictly prohibited.
2. The exports of SMC products or technology from one country to another are governed by the relevant security laws and regulations of the countries involved in the transaction. Prior to the shipment of a SMC product to another country, assure that all local rules governing that export are known and followed.

Safety Instructions

Be sure to read “Handling Precautions for SMC Products” (M-E03-3) before using.

SMC Corporation (Europe)

Austria	☎ +43 2262622800	www.smc.at	office@smc.at
Belgium	☎ +32 (0)33551464	www.smcpnematics.be	info@smcpnematics.be
Bulgaria	☎ +359 29744492	www.smc.bg	office@smc.bg
Croatia	☎ +385 13776674	www.smc.hr	office@smc.hr
Czech Republic	☎ +420 541424611	www.smc.cz	office@smc.cz
Denmark	☎ +45 70252900	www.smc.dk.com	smc@smcdk.com
Estonia	☎ +372 6510370	www.smcpnematics.ee	smc@smcpnematics.ee
Finland	☎ +358 207513513	www.smc.fi	smcfin@smc.fi
France	☎ +33 (0)164761000	www.smc-france.fr	contact@smc-france.fr
Germany	☎ +49 (0)61034020	www.smc-pneumatik.de	info@smc-pneumatik.de
Greece	☎ +30 210 2717265	www.smchellas.gr	sales@smchellas.gr
Hungary	☎ +36 23511390	www.smc.hu	office@smc.hu
Ireland	☎ +353 (0)14039000	www.smcpnematics.ie	sales@smcpnematics.ie
Italy	☎ +39 (0)292711	www.smcitalia.it	mailbox@smcitalia.it
Latvia	☎ +371 67817700	www.smc.lv	info@smclv.lv

Lithuania	☎ +370 5 2308118	www.smclt.lt	info@smclt.lt
Netherlands	☎ +31 (0)205318888	www.smcpnematics.nl	info@smcpnematics.nl
Norway	☎ +47 67129020	www.smc-norge.no	post@smc-norge.no
Poland	☎ +48 222119600	www.smc.pl	office@smc.pl
Portugal	☎ +351 226166570	www.smc.eu	postpt@smc.smces.es
Romania	☎ +40 213205111	www.smcromania.ro	smcromania@smcromania.ro
Russia	☎ +7 8127185445	www.smc-pneumatik.ru	info@smc-pneumatik.ru
Slovakia	☎ +421 413213212	www.smc.sk	office@smc.sk
Slovenia	☎ +386 73885412	www.smc.si	office@smc.si
Spain	☎ +34 945184100	www.smc.eu	post@smc.smces.es
Sweden	☎ +46 (0)86031200	www.smc.nu	post@smcpnematics.se
Switzerland	☎ +41 (0)523963131	www.smc.ch	info@smc.ch
Turkey	☎ +90 (0)2124440762	www.entek.com.tr	smc@entek.com.tr
UK	☎ +44 (0)845 121 5122	www.smcpnematics.co.uk	sales@smcpnematics.co.uk