

GN 413 | Indexing plungers

With or without rest position, steel or stainless steel

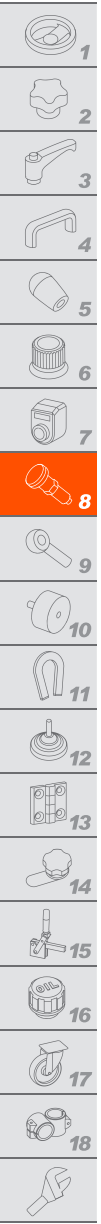

1 THREADED BODY

Zinc-plated steel (ST index).
AISI 303 stainless steel (NI index).

2 STANDARD EXECUTIONS

- **GN 413-A:** without rest position, without locking nut.
 - **GN 413-AK:** without rest position, with locking nut.
 - **GN 413-C:** with rest position, without locking nut.
 - **GN 413-CK:** with rest position, with locking nut.
- Index for material indexing plunger body and locking nut:
- **ST:** black-oxide steel.
- **NI:** AISI 303 stainless steel.

3 PLUNGER

AISI 303 stainless steel.

4 SPRING AND LIFTING RING

AISI 301 stainless steel.

5 FEATURES AND APPLICATIONS

Thanks to its special shape, the lifting ring of GN 413 indexing plungers can be used both for screwing during assembly and for locking the plunger in the retracted position (GN413-C / GN 413-CK).

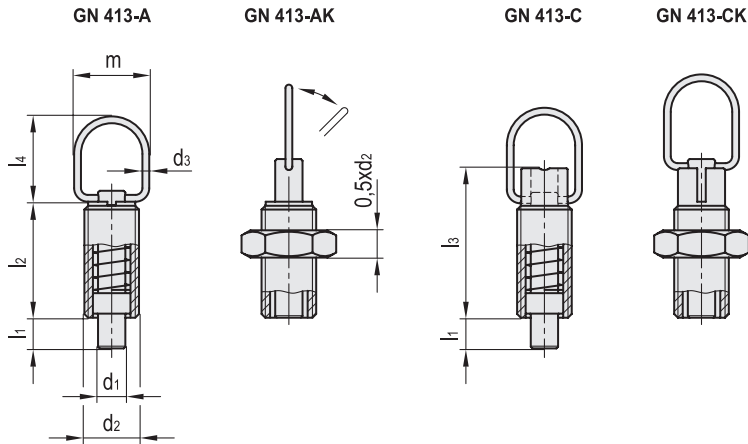

GN 413-ST

Code	Description	d1								Spring preload [N]	Spring max load [N]	
		Plunger Hole H7 -0.05-0.10	d2	d3	l1 min	l2	l3	l4	m			
GN.26342	GN 413-5-M10-A-ST	5	M10	1.5	5	22	-	23	18	5	15	10
GN.26347	GN 413-5-M10x1-A-ST	5	M10	1.5	5	22	-	23	18	5	15	10
GN.26352	GN 413-6-M12-A-ST	6	M12	2	6	24	-	25	22	6	21	18
GN.26357	GN 413-6-M12x1.5-A-ST	6	M12x1.5	2	6	24	-	25	22	6	21	18
GN.26362	GN 413-8-M16-A-ST	8	M16	2	9	34	-	25	22	7	27	45
GN.26367	GN 413-8-M16x1.5-A-ST	8	M16x1.5	2	9	34	-	25	22	7	27	45
GN.26372	GN 413-10-M16-A-ST	10	M16	2	9	34	-	25	22	7	27	47
GN.26377	GN 413-10-M16x1.5-A-ST	10	M16x1.5	2	9	34	-	25	22	7	27	47
GN.26382	GN 413-5-M10-AK-ST	5	M10	1.5	5	22	-	28	22	5	15	10
GN.26387	GN 413-5-M10x1-AK-ST	5	M10	1.5	5	22	-	28	22	5	15	10
GN.26392	GN 413-6-M12-AK-ST	6	M12	2	6	24	-	25	22	6	21	18
GN.26397	GN 413-6-M12x1.5-AK-ST	6	M12x1.5	2	6	24	-	25	22	6	21	18
GN.26412	GN 413-8-M16-AK-ST	8	M16	2	9	34	-	25	22	7	27	45
GN.26417	GN 413-8-M16x1.5-AK-ST	8	M16x1.5	2	9	34	-	25	22	7	27	45
GN.26422	GN 413-10-M16-AK-ST	10	M16	2	9	34	-	25	22	7	27	47
GN.26427	GN 413-10-M16x1.5-AK-ST	10	M16x1.5	2	9	34	-	25	22	7	27	47
GN.26344	GN 413-5-M10-C-ST	5	M10	1.5	5	-	28	23	18	5	15	13
GN.26349	GN 413-5-M10x1-C-ST	5	M10	1.5	5	-	28	23	18	5	15	13
GN.26354	GN 413-6-M12-C-ST	6	M12	2	6	-	31	25	22	6	21	21
GN.26359	GN 413-6-M12x1.5-C-ST	6	M12x1.5	2	6	-	31	25	22	6	21	21
GN.26364	GN 413-8-M16-C-ST	8	M16	2	9	-	44	25	22	7	27	51
GN.26369	GN 413-8-M16x1.5-C-ST	8	M16x1.5	2	9	-	44	25	22	7	27	51
GN.26374	GN 413-10-M16-C-ST	10	M16	2	9	-	44	25	22	7	27	59
GN.26379	GN 413-10-M16x1.5-C-ST	10	M16x1.5	2	9	-	44	25	22	7	27	59
GN.26384	GN 413-5-M10-CK-ST	5	M10	1.5	5	-	28	23	18	5	15	13
GN.26389	GN 413-5-M10x1-CK-ST	5	M10	1.5	5	-	28	23	18	5	15	13
GN.26394	GN 413-6-M12-CK-ST	6	M12	2	6	-	31	25	22	6	21	21
GN.26399	GN 413-6-M12x1.5-CK-ST	6	M12x1.5	2	6	-	31	25	22	6	21	21
GN.26414	GN 413-8-M16-CK-ST	8	M16	2	9	-	44	25	22	7	27	51
GN.26419	GN 413-8-M16x1.5-CK-ST	8	M16x1.5	2	9	-	44	25	22	7	27	51
GN.26424	GN 413-10-M16-CK-ST	10	M16	2	9	-	44	25	22	7	27	59
GN.26429	GN 413-10-M16x1.5-CK-ST	10	M16x1.5	2	9	-	44	25	22	7	27	59

GN 413-NI

INOX STAINLESS STEEL

GN.26341	GN 413-5-M10-A-NI	5	M10	1.5	5	22	-	23	18	5	15	10
GN.26346	GN 413-5-M10x1-A-NI	5	M10	1.5	5	22	-	23	18	5	15	10
GN.26351	GN 413-6-M12-A-NI	6	M12	2	6	24	-	25	22	6	21	18
GN.26356	GN 413-6-M12x1.5-A-NI	6	M12x1.5	2	6	24	-	25	22	6	21	18
GN.26361	GN 413-8-M16-A-NI	8	M16	2	9	34	-	25	22	7	27	45
GN.26366	GN 413-8-M16x1.5-A-NI	8	M16x1.5	2	9	34	-	25	22	7	27	45
GN.26371	GN 413-10-M16-A-NI	10	M16	2	9	34	-	25	22	7	27	47
GN.26376	GN 413-10-M16x1.5-A-NI	10	M16x1.5	2	9	34	-	25	22	7	27	47
GN.26381	GN 413-5-M10-AK-NI	5	M10	1.5	5	22	-	23	18	5	15	10
GN.26386	GN 413-5-M10x1-AK-NI	5	M10	1.5	5	22	-	23	18	5	15	10
GN.26391	GN 413-6-M12-AK-NI	6	M12	2	6	24	-	25	22	6	21	18
GN.26396	GN 413-6-M12x1.5-AK-NI	6	M12x1.5	2	6	24	-	25	22	6	21	18
GN.26411	GN 413-8-M16-AK-NI	8	M16	2	9	34	-	25	22	7	27	45
GN.26416	GN 413-8-M16x1.5-AK-NI	8	M16x1.5	2	9	34	-	25	22	7	27	45
GN.26421	GN 413-10-M16-AK-NI	10	M16	2	9	34	-	25	22	7	27	47
GN.26426	GN 413-10-M16x1.5-AK-NI	10	M16x1.5	2	9	34	-	25	22	7	27	47
GN.26343	GN 413-5-M10-C-NI	5	M10	1.5	5	-	28	23	18	5	15	13
GN.26348	GN 413-5-M10x1-C-NI	5	M10	1.5	5	-	28	23	18	5	15	13
GN.26353	GN 413-6-M12-C-NI	6	M12	2	6	-	31	25	22	6	21	21
GN.26358	GN 413-6-M12x1.5-C-NI	6	M12x1.5	2	6	-	31	25	22	6	21	21
GN.26363	GN 413-8-M16-C-NI	8	M16	2	9	-	44	25	22	7	27	51
GN.26368	GN 413-8-M16x1.5-C-NI	8	M16x1.5	2	9	-	44	25	22	7	27	51
GN.26373	GN 413-10-M16-C-NI	10	M16	2	9	-	44	25	22	7	27	59
GN.26378	GN 413-10-M16x1.5-C-NI	10	M16x1.5	2	9	-	44	25	22	7	27	59
GN.26383	GN 413-5-M10-CK-NI	5	M10	1.5	5	-	28	23	18	5	15	13
GN.26388	GN 413-5-M10x1-CK-NI	5	M10	1.5	5	-	28	23	18	5	15	13
GN.26393	GN 413-6-M12-CK-NI	6	M12	2	6	-	31	25	22	6	21	21
GN.26398	GN 413-6-M12x1.5-CK-NI	6	M12x1.5	2	6	-	31	25	22	6	21	21
GN.26413	GN 413-8-M16-CK-NI	8	M16	2	9	-	44	25	22	7	27	51
GN.26418	GN 413-8-M16x1.5-CK-NI	8	M16x1.5	2	9	-	44	25	22	7	27	51
GN.26423	GN 413-10-M16-CK-NI	10	M16	2	9	-	44	25	22	7	27	59
GN.26428	GN 413-10-M16x1.5-CK-NI	10	M16x1.5	2	9	-	44	25	22	7	27	59

