

ME. | Balanced crank handles

Duroplast



MATERIAL

Reinforced phenolic based (PF) Duroplast. Polyamide based (PA) technopolymer for ME.95, black colour, glossy finish. Balancing by means of an incorporated counterweight.

FRONT PLATE

Matte anodised aluminium (ELESA original design).

STANDARD EXECUTION

Black-oxide steel boss, H7 reamed hole.
Reamed hole provided with centres already drilled for pinning to shaft.
Use pins with smaller diameter than the one of the already drilled hole to avoid local stress.
Revolving handle I.301+x (see page 574) in Duroplast.



ELESA Original design

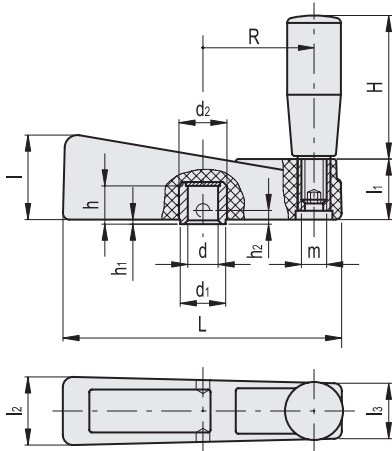

Code	Description	dH7	L	d1	d2	l	l1	l2	l3	h	h1	h2	H	m	R	Δ
38001	ME.65	8	65	13	14	23	18	22	19	13	1.5	6.5	40	M6	23	93
38101	ME.80	10	80	14	15	26	20	24	20	16	1.5	8	40	M6	30	102
38201	ME.95	10	94	14	15	29	22	26	22	19	1.5	8	50	M8	36	133
38301	ME.110	12	110	18	19	34	24	28	22	17.5	1.5	9	65	M10	44	260
38401	ME.140	12	140	18	19	37	26	30	24	17.5	1.5	9	80	M10	57	335

GN 112.1 | Balanced crank handles

Zinc-alloy



MATERIAL

Die-cast zinc-alloy, epoxy resin coating, RAL 9005 black colour, matte finish.

STANDARD EXECUTION

H7 reamed blind hole.
Revolving handle I.601+x (see page 574) in technopolymer.

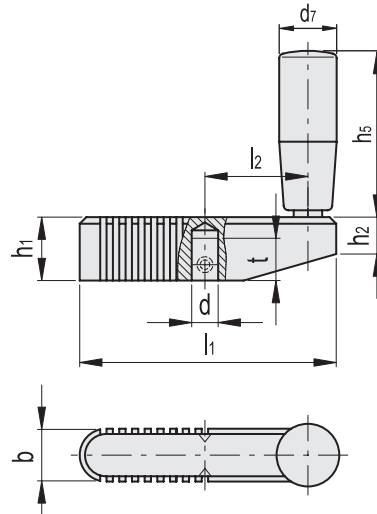

Code	Description	dH7	l1	l2	h1	h2	h5	b	tmin	d7	Δ
GN.11551	GN 112.1-70-S8	8	70	26.5	19	11.5	42.5	17	12	18	125
GN.11561	GN 112.1-80-S8	8	80	31	21	12.5	52.5	18	12	21	170
GN.11565	GN 112.1-90-S10	10	90	35.5	23	13.5	52.5	19	15	21	251
GN.11571	GN 112.1-100-S10	10	100	40	25	14	67.5	20	17	23	290
GN.11581	GN 112.1-100-S12	12	100	40	25	14	67.5	20	17	23	285

- 1
- 2
- 3
- 4
- 5
- 6
- 7
- 8
- 9
- 10
- 11
- 12
- 13
- 14
- 15
- 16
- 17
- 18

Operating elements