

E3M151

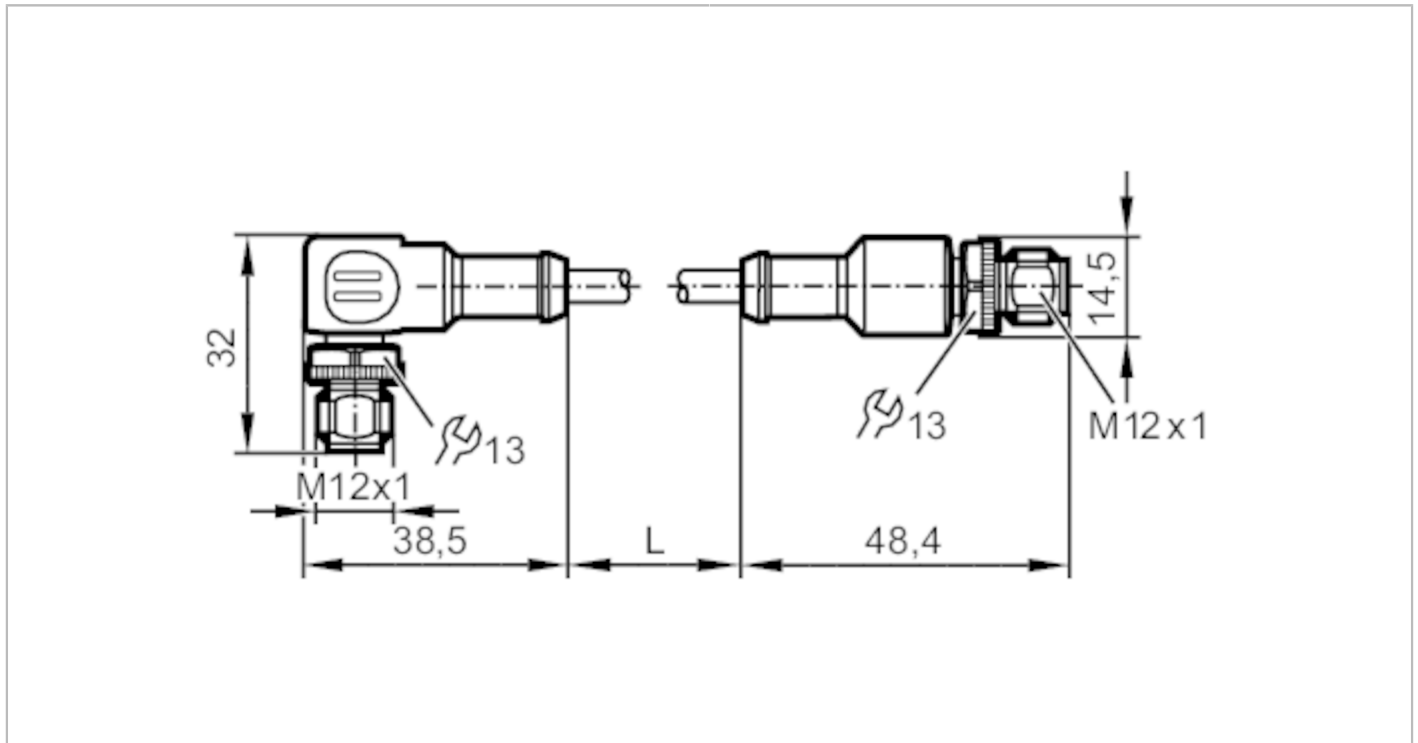

Connection cable

CONNECTION CABLE M12 5M



Application	
Special feature	Screened cable; Drag chain suitability
Design	for 3D Smart sensor mobile with analogue video output PAL
Electrical data	
Operating voltage [V]	< 50 AC / < 60 DC
Protection class	III
Operating conditions	
Ambient temperature [°C]	-40...80
Protection	IP 67; IP 69K
Mechanical data	
Weight [g]	277.3
Materials	housing: PUR; Sealing: FKM; contact pins: CuSn6 nickel-plated and tin-plated
Material nut	stainless steel (1.4305 / 303) / stainless steel (1.4305 / 303)
Drag chain suitability	yes
Drag chain suitability	bending radius for fixed installation ≥ 60 mm
Remarks	
Pack quantity	1 pcs.
Electrical connection - plug	
Connector: 1 x M12, angled; Locking: stainless steel (1.4305 / 303)	

E3M151



Connection cable

CONNECTION CABLE M12 5M

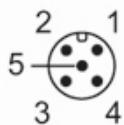

Electrical connection

Cable: 5 m, TPU, black, Ø 6 mm, shielded; 3 x 0.25 mm²

Connection

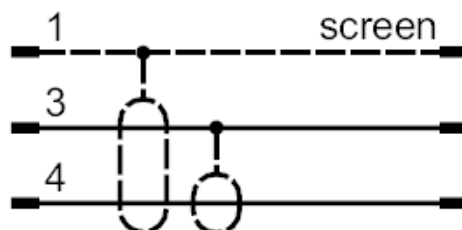

- | | |
|----|-----------------|
| 1: | screen |
| 2: | not used |
| 3: | coax screen |
| 4: | coax cable core |
| 5: | not used |

Electrical connection - plug

Connector: 1 x M12, straight; Locking: stainless steel (1.4305 / 303)

