

DATA SHEET

GAS DISCHARGE TUBES TELEPHONE INTERFACE

2R-8x6(S) series

RoHS compliant & Halogen free



Product specification— November 05, 2018 V.0



Gas Discharge Tube (GDT) Data Sheet

Features

- Provide ultra-fast response to surge voltage from slow-rising surge of 100V/s to rapid-rising surge of 1KV/μs.
- Stable breakdown voltage.
- High insulation resistance.
- Low capacitance (≤1.5pF)
- High holdover voltage
- Large absorbing transient current capability.
- Micro-Gap Design
- Size: 8.0mm*6.0mm
- Storage and operating temperature: -40°C ~ +85°C
- Meets MSL level 1, per J-STD-020
- Safety certification: E244458 & E327997



Applications

- Repeaters, Modems.
- Telephone Interface, Line cards.
- Data communication equipment.
- Line test equipment

Part Number Code

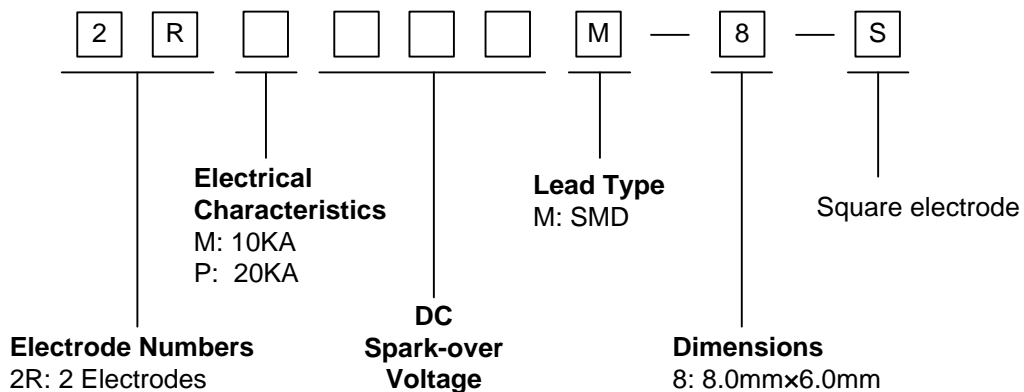

Marking

B : BrightKing Logo
 2RM090-8 : Device Marking Code
 YXXX : Date Code

Dimensions

Symbol	Dimension (mm)	
	Spec.	Tolerance
A	8.00	±0.20
B	0.50	±0.10
D	8.30	±0.20
T	6.00	±0.25
S	9.00	±0.40

Electrical Characteristics

Part Number	DC Spark-over Voltage	Maximum Impulse Spark-over Voltage	Nominal Impulse Discharge Current	Single Impulse Discharge Current	Alternating Discharge Current	Impulse Life	Minimum Insulation Resistance		Maximum Capacitance	Device Marking Code
	100V/s	1000V/μs	8/20μs 10times	10/350μs	50Hz, 1sec	10/1000μs 100A	Test Voltage	(GΩ)	1MHz	
	(V)	(V)	(KA)	(KA)	(A)	(times)	DC(V)		(pF)	
2RM075M-8-S	75±20%	600	10	2.5	10	500	25	1.0	1.5	2RM075-8
2RM090M-8-S	90±20%	600	10	2.5	10	500	50	1.0	1.5	2RM090-8
2RM150M-8-S	150±20%	600	10	2.5	10	500	100	1.0	1.5	2RM150-8
2RM230M-8-S	230±20%	700	10	2.5	10	500	100	1.0	1.5	2RM230-8
2RM250M-8-S	250±20%	700	10	2.5	10	500	100	1.0	1.5	2RM250-8
2RM300M-8-S	300±20%	900	10	2.5	10	500	100	1.0	1.5	2RM300-8
2RM350M-8-S	350±20%	900	10	2.5	10	500	100	1.0	1.5	2RM350-8
2RM420M-8-S	420±20%	1000	10	2.5	10	500	100	1.0	1.5	2RM420-8
2RM470M-8-S	470±20%	1000	10	2.5	10	500	250	1.0	1.5	2RM470-8
2RM600M-8-S	600±20%	1200	10	2.5	10	500	250	1.0	1.5	2RM600-8
2RM800M-8-S	800±20%	1400	10	2.5	10	500	250	1.0	1.5	2RM800-8
2RM1000M-8-S	1000±20%	1700	10	2.5	10	500	250	1.0	1.5	2RM1000-8
2RP075M-8-S	75±20%	600	20	5.0	20	500	25	1.0	1.5	2RP075-8
2RP090M-8-S	90±20%	600	20	5.0	20	500	50	1.0	1.5	2RP090-8
2RP150M-8-S	150±20%	600	20	5.0	20	500	100	1.0	1.5	2RP150-8
2RP230M-8-S	230±20%	700	20	5.0	20	500	100	1.0	1.5	2RP230-8
2RP250M-8-S	250±20%	700	20	5.0	20	500	100	1.0	1.5	2RP250-8
2RP300M-8-S	300±20%	900	20	5.0	20	500	100	1.0	1.5	2RP300-8
2RP350M-8-S	350±20%	900	20	5.0	20	500	100	1.0	1.5	2RP350-8
2RP420M-8-S	420±20%	1000	20	5.0	20	500	100	1.0	1.5	2RP420-8
2RP470M-8-S	470±20%	1000	20	5.0	20	500	250	1.0	1.5	2RP470-8
2RP600M-8-S	600±20%	1200	20	5.0	20	500	250	1.0	1.5	2RP600-8
2RP800M-8-S	800±20%	1400	20	5.0	20	500	250	1.0	1.5	2RP800-8
2RP1000M-8-S	1000±20%	1700	20	5.0	20	500	250	1.0	1.5	2RP1000-8

Electrical Ratings

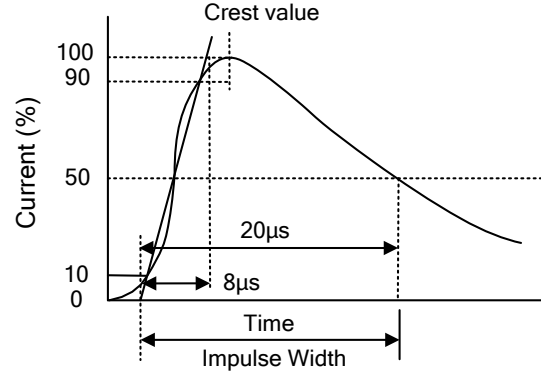
Items	Test Condition/Description	Requirement
DC Spark-over Voltage	The voltage is measured with voltage ramp $dv/dt=100V/s$.	To meet the specified value
Maximum Impulse Spark-over Voltage	The maximum impulse spark-over voltage is measured with voltage ramp $dv/dt=1000V/\mu s$.	
Impulse Discharge Current	Maximum 8/20 μs surge current that can be applied between two electrodes, 5 positive and 5 negative surges, with 3 minutes interval time. <div style="text-align: center;">  <p>The graph shows a typical 8/20 microsecond surge current waveform. The y-axis represents Current (%) from 0 to 100. The x-axis represents Time. The curve starts at 0, rises to a peak (Crest value) of 100% at approximately 8 microseconds. It then decays, crossing 50% current at 20 microseconds. The total duration of the impulse is labeled as Impulse Width.</p> </div>	
Alternating Discharge Current	Rated RMS value of AC current at 50Hz, 1 sec. for 10 times with interval time 3 min.	
Insulation Resistance	The resistance of gas tube shall be measured between two electrodes.	
Capacitance	The capacitance of gas tube shall be measured between two electrodes. Test frequency: 1MHz	

Recommended Soldering Conditions

Reflow Soldering

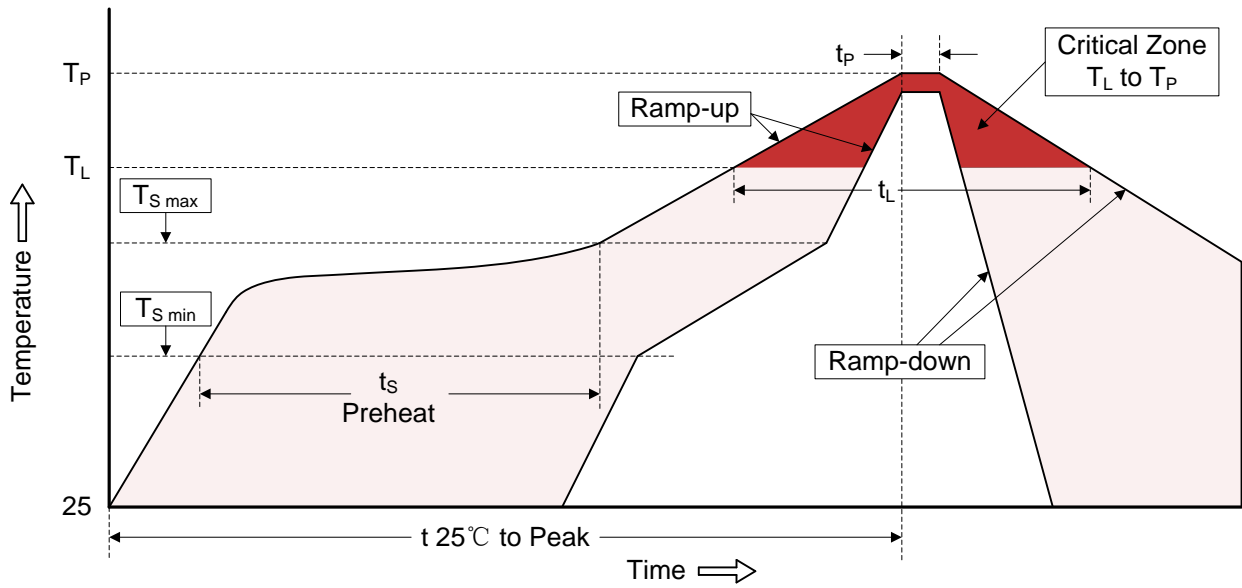

Recommended Conditions

Profile Feature	Pb-Free Assembly
Average ramp-up rate (T_L to T_P)	3°C/second max.
Preheat -Temperature Min ($T_{S\ min}$) -Temperature Max ($T_{S\ max}$) -Time (min to max) (t_s)	150°C 200°C 60-180 seconds
$T_{S\ max}$ to T_L -Ramp-up Rate	3°C/second max.
Time maintained above: -Temperature (T_L) -Time (t_L)	217°C 60-150 seconds
Peak Temperature (T_P)	260°C
Time within 5°C of actual Peak Temperature (t_p)	20-40 seconds
Ramp-down Rate	6°C/second max.
Time 25°C to Peak Temperature	8 minutes max.

Packaging

Tape	Symbol	Dimension (mm)		
		Spec.	Tolerance	
	W	16.00	±0.20	
	P0	4.00	±0.10	
	P1	12.00	±0.20	
	P2	2.00	±0.10	
	D0	1.55	±0.05	
	E	1.75	±0.10	
	F	7.50	±0.10	
	A0	6.35	±0.10	
	K0	6.55	±0.10	
	B0	8.65	±0.10	
	t0	0.50	±0.10	
	Reel	D	330.00	±1.00
		d	13.00	±0.50
L		20.00	±0.50	
t		2.00	±0.20	
Quantity: 600pcs				