

Features

- Easy to install: fast and simple integration ensure stable performance in any application
- Waterproof, IP66 / IP68 protection
- Safe and reliable
- For use with outdoor lighting, sensor equipment, outdoor communication equipment & more

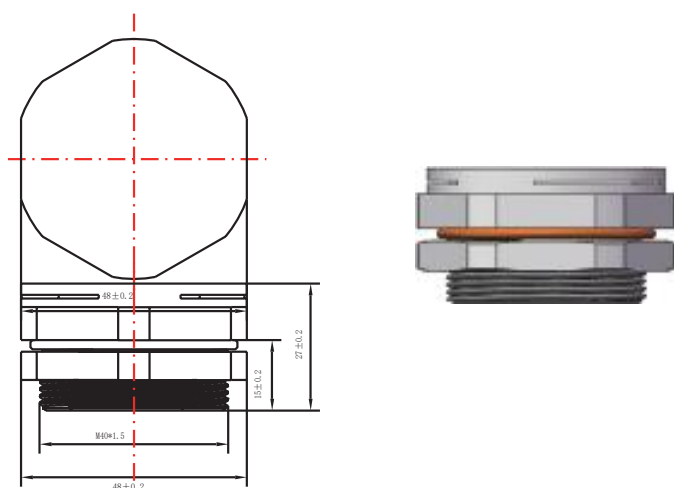

Specification

Air Permeability	16000-40000 ml/min@0.07bar
Membrane Material	ePTFE
Membrane Characteristics	Oleophobic & Hydrophobic
Body Material	Aluminium Alloy
Colour	Silver
Torque Wrench Size	48
O-ring Material	Silica gel 60H shore hardness A
Clamping Nut Material	Aluminium Alloy
Flammability Level	V0
Salt Resistance	PH 1-14
Antibacterial Level (GB/T 2423.16)	1 Level
Anti High & Low Temperature	-
IP Level	IP66 / IP68
Traceability	With Independent Laser Serial No.
Recommended Torque	3.6±0.2N.m
Installation	Thread

Art. Nr.
RND 455-01120