

- 1
- 2
- 3
- 4
- 5
- 6
- 7
- 8
- 9
- 10
- 11
- 12
- 13
- 14
- 15
- 16
- 17
- 18

BASE

Glass-fibre reinforced polyamide based (PA) technopolymer, black colour, matte finish.

ARTICULATED STEM

Threaded AISI 304 stainless steel with adjusting square.

STANDARD EXECUTIONS

- LVQ.F-SST: without no-slip disk.
- LVQ.F-AS-SST: with NBR rubber no-slip disk, hardness 70 Shore A, supplied assembled to the base.

GROUND MOUNTING

By means of two holes at 180°, supplied covered by a diaphragm (which can be easily removed by a metal tool), to avoid all unhealthy deposits of dirt and dust when the ground mounting is not required (see Fig. 1).

FEATURES

The special knurling under the lower lip of the base provides excellent stability and grip when using the levelling element without no-slip disk even on surfaces that are not perfectly flat.

The particular assembling system of the no-slip disk to the base assures a perfect anchoring, preventing separation even in case of impact during transport or of adhesion (sticking) to the floor (see No-slip disks on page 1137).

ORDER INFORMATION

The levelling elements are supplied unassembled to make carriage and storage easier. The components (base and stem) are supplied in separate packing: less volume taken and better protection from scratches and dirt.

To order bases and stems separately, see:

- table of possible combinations Bases/Stems (see page 1144)
- the codes of the Bases (see page 1139)
- the codes of the Stems (see page 1142).

ACCESSORIES ON REQUEST

AISI 304 stainless steel nut (see Nuts NT. on page 1137).



ELESA Original design

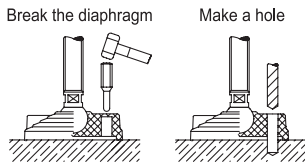
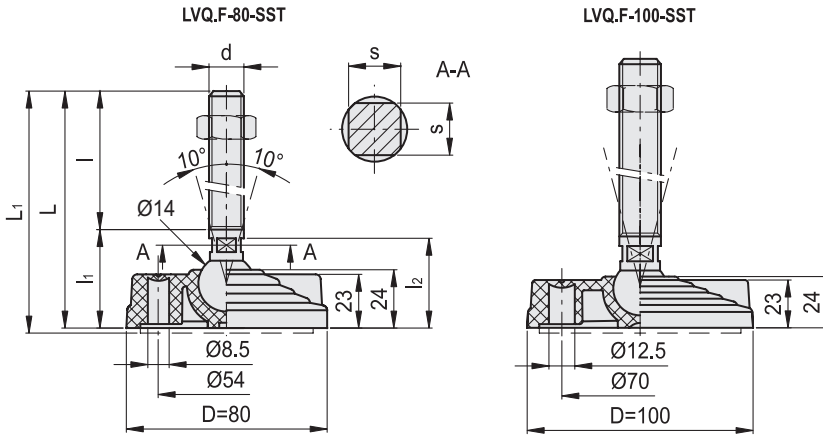

Fig.1



LVQ.F-SST

LVQ.F-AS-SST



Code	Description	Code	Description	D	d	L	L1#	l	l1	l2	s	Max. limit stati load* [N]	#
332001	LVQ.F-80-14-SST-M16x68	335001	LVQ.F-80-14-AS-SST-M16x68	80	M16	102	105	68	34	32.5	12	16000	151 177
332003	LVQ.F-80-14-SST-M16x108	335003	LVQ.F-80-14-AS-SST-M16x108	80	M16	142	145	108	34	32.5	12	16000	215 241
332005	LVQ.F-80-14-SST-M16x148	335005	LVQ.F-80-14-AS-SST-M16x148	80	M16	182	185	148	34	32.5	12	16000	279 305
332007	LVQ.F-80-14-SST-M16x168	335007	LVQ.F-80-14-AS-SST-M16x168	80	M16	202	205	168	34	32.5	12	16000	311 337
332011	LVQ.F-80-14-SST-M20x110	335011	LVQ.F-80-14-AS-SST-M20x110	80	M20	149	152	110	39	36.5	15	16000	315 341
332013	LVQ.F-80-14-SST-M20x150	335013	LVQ.F-80-14-AS-SST-M20x150	80	M20	189	192	150	39	36.5	15	16000	415 441
332015	LVQ.F-80-14-SST-M20x170	335015	LVQ.F-80-14-AS-SST-M20x170	80	M20	209	212	170	39	36.5	15	16000	465 491
332017	LVQ.F-80-14-SST-M20x210	335017	LVQ.F-80-14-AS-SST-M20x210	80	M20	249	252	210	39	36.5	15	16000	564 590
332021	LVQ.F-80-14-SST-M24x110	335021	LVQ.F-80-14-AS-SST-M24x110	80	M24	149	152	110	39	36.5	18	16000	422 448
332023	LVQ.F-80-14-SST-M24x170	335023	LVQ.F-80-14-AS-SST-M24x170	80	M24	209	212	170	39	36.5	18	16000	637 663
332025	LVQ.F-80-14-SST-M24x210	335025	LVQ.F-80-14-AS-SST-M24x210	80	M24	249	252	210	39	36.5	18	16000	781 807
333851	LVQ.F-100-14-SST-M16x68	335851	LVQ.F-100-14-AS-SST-M16x68	100	M16	102	105	68	34	32.5	12	16000	181 235
333853	LVQ.F-100-14-SST-M16x108	335853	LVQ.F-100-14-AS-SST-M16x108	100	M16	142	145	108	34	32.5	12	16000	245 299
333855	LVQ.F-100-14-SST-M16x148	335855	LVQ.F-100-14-AS-SST-M16x148	100	M16	182	185	148	34	32.5	12	16000	309 363
333857	LVQ.F-100-14-SST-M16x168	335857	LVQ.F-100-14-AS-SST-M16x168	100	M16	202	205	168	34	32.5	12	16000	341 395
333861	LVQ.F-100-14-SST-M20x110	335861	LVQ.F-100-14-AS-SST-M20x110	100	M20	149	152	110	39	36.5	15	16000	345 399
333863	LVQ.F-100-14-SST-M20x150	335863	LVQ.F-100-14-AS-SST-M20x150	100	M20	189	192	150	39	36.5	15	16000	445 499
333865	LVQ.F-100-14-SST-M20x170	335865	LVQ.F-100-14-AS-SST-M20x170	100	M20	209	212	170	39	36.5	15	16000	495 549
333867	LVQ.F-100-14-SST-M20x210	335867	LVQ.F-100-14-AS-SST-M20x210	100	M20	249	252	210	39	36.5	15	16000	594 648
333871	LVQ.F-100-14-SST-M24x110	335871	LVQ.F-100-14-AS-SST-M24x110	100	M24	149	152	110	39	36.5	18	16000	452 506
333873	LVQ.F-100-14-SST-M24x170	335873	LVQ.F-100-14-AS-SST-M24x170	100	M24	209	212	170	39	36.5	18	16000	667 721
333875	LVQ.F-100-14-SST-M24x210	335875	LVQ.F-100-14-AS-SST-M24x210	100	M24	249	252	210	39	36.5	18	16000	811 865

* The max static load is the value above which the load applied to the element may cause some plastic material breakage, in particular conditions of use. Obviously, a factor that takes into consideration the importance and the safety level of the specific application must be applied to this value.

Data with no-slip disk mounted.

