



Part no.: 63000308
S300-P13C1-M20-SB
Safety position switch



Figure can vary



Contents

- Technical data
- Dimensioned drawings
- Electrical connection
- Circuit diagrams
- Notes

Technical data

Basic data	
Series	S300
Functions	
Functions	Integration in control circuits up to category 4 in accordance with EN ISO 13849 Locking device without guard interlocking according to ISO 14119
Characteristic parameters	
Mission time T_M	20 years , EN ISO 13849-1
B10 _d	40,000,000 number of cycles
Electrical data	
Usage category at DC 13	Ue / Ie: 24 V / 6 A, 125 V / 1.1 A, 250 V / 0.4 A , EN 60947-5-1
Usage category at AC 15	Ue / Ie: 250 V / 6 A, 400 V / 4 A, 500 V / 1 A , EN 60947-5-1
Contact allocation	2NC + 1NO
Contact opening	Force-fit
Short circuit protected	500 V, 10 A, type aM , IEC 60269-1
Contact protection	Protective insulation O
Performance data	
Rated insulation voltage	400 V AC, 500 V DC
Conventional thermal current, max.	10 A
Connection	
Number of connections	1 Piece(s)
Number of cable entries	1 Piece(s)
Connection 1	
Type of connection	Terminal
Function	Contact connection
Type of terminal	Screw terminal
No. of pins	6 -pin
Cable properties	
Connection cross sections	1 x 0.34 mm ² to 2 x 1.5 mm ² , wire
Mechanical data	
Design	Cubic
Dimension (W x H x L)	40 mm x 39 mm x 97 mm
Housing material	Plastic , Glass fiber reinforced (PPS), self-extinguishing
Electrical contact material	Silver alloy
Net weight	155 g
Housing color	Black
Type of fastening	Through-hole mounting
Type of cable entry	M20 x 1.5
Switch type	Interlock device without guard interlocking , ISO 14119
Switching principle	Slow-action contact
Switching direction	Both sides One side
Approach actuation directions	360° 4 x side (90°)

Part no.: 63000308 – S300-P13C1-M20-SB – Safety position switch

Approach speed	Depending on actuator used
Mechanical life time	20,000,000 actuation cycles , IEC 60947-5-1 switching cycles
Actuation frequency, max.	3,600 per hour , IEC 60947-5-1
Actuator mount	Long

Environmental data	
Ambient temperature, operation	-25 ... 80 °C
Degree of contamination	3 , EN 60947-1

Certifications	
Degree of protection	IP 67
Certifications	c UL US IMQ

Classification	
Customs tariff number	85369095
eCl@ss 8.0	27272601
eCl@ss 9.0	27272601
ETIM 5.0	EC000030
ETIM 6.0	EC000030

Dimensioned drawings

All dimensions in millimeters

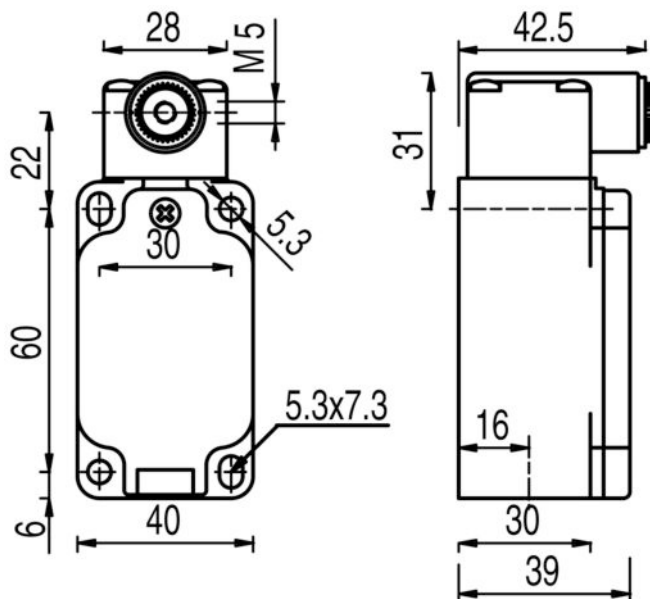

Electrical connection

Connection 1	
Type of connection	Terminal

Part no.: 63000308 – S300-P13C1-M20-SB – Safety position switch

Connection 1	
Function	Contact connection
Type of terminal	Screw terminal
No. of pins	6 -pin

Terminal	Assignment
11	NC(1)
12	NC(1)
21	NC(2)
22	NC(2)
33	NO(1)
34	NO(1)

Circuit diagrams

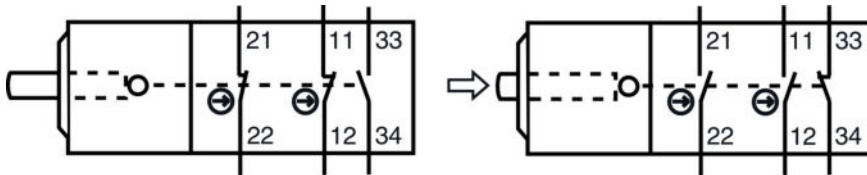

Notes

Observe intended use!

- The product may only be put into operation by competent persons.
- Only use the product in accordance with its intended use.