



### Model Number

**PGV100-F200A-B16-V15**

Read head for incident light positioning system

### Features

- **Mechanically rugged: no wearing parts, long operating life, maintenance-free**
- **CANopen interface**
- **Noncontact lane tracking of a colored strip**
- **Noncontact positioning along the colored strip using Data Matrix codes**
- **Reading of Data Matrix control codes**

### Diagrams

#### Coordinates

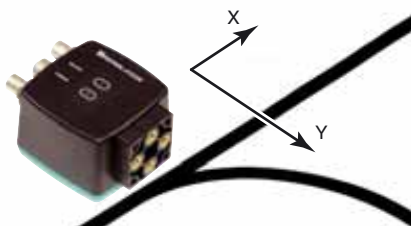

Release date: 2017-03-24 11:45 Date of issue: 2017-03-24 258089\_eng.xml

## Technical data

### General specifications

Passage speed $v$	$\leq 8$ m/s
Measuring range	max. 10000 m
Light type	Integrated LED lightning (white/blue)
Read distance	100 mm
Depth of focus	$\pm 20$ mm
Reading field	120 mm x 80 mm
Ambient light limit	100000 Lux
Resolution	$\pm 0.2$ mm

### Nominal ratings

Camera	
Type	CMOS , Global shutter
Processor	
Clock pulse frequency	600 MHz
Speed of computation	4800 MIPS

### Functional safety related parameters

MTTF <sub>d</sub>	99 a
Mission Time (T <sub>M</sub> )	49 a
Diagnostic Coverage (DC)	0 %

### Indicators/operating means

LED indicator	7 LEDs (communication, alignment aid, status information)
---------------	---

### Electrical specifications

Operating voltage $U_B$	15 ... 30 V DC , PELV
No-load supply current $I_0$	max. 400 mA
Power consumption $P_0$	6 W

### Interface

Interface type	CANopen , galvanically isolated
Data output code	binary code
Transfer rate	max. 1 MBit/s

### Interface 2

Interface type	USB Service
----------------	-------------

### Input

Input type	1 function input 0-level: $-U_B$ or unwired 1-level: $+8$ V ... $+U_B$ , programmable
Input impedance	$\geq 27$ k $\Omega$

### Output

Output type	1 to 3 switch outputs , programmable , short-circuit protected
Switching voltage	Operating voltage
Switching current	150 mA each output

### Standard conformity

Emitted interference	EN 61000-6-4:2007+A1:2011
Noise immunity	EN 61000-6-2:2005
Shock resistance	EN 60068-2-27:2009
Vibration resistance	EN 60068-2-6:2008

### Ambient conditions

Operating temperature	0 ... 60 °C (32 ... 140 °F) , -20 ... 60 °C (-4 ... 140 °F) (noncondensing; prevent icing on the lens!)
Relative humidity	90 % , noncondensing

### Mechanical specifications

Connection type	8-pin, M12x1 connector, standard (supply+IO) 5-pin, M12x1 socket, A-coded (bus out/termination) 5-pin, M12x1 connector, A-coded (bus in)
Housing width	70 mm
Housing height	70 mm
Degree of protection	IP67
Material	
Housing	PC/ABS
Mass	approx. 200 g

### Approvals and certificates

UL approval	cULus Listed, General Purpose, Class 2 Power Source, Type 1 enclosure
CCC approval	CCC approval / marking not required for products rated $\leq 36$ V

**Dimensions**

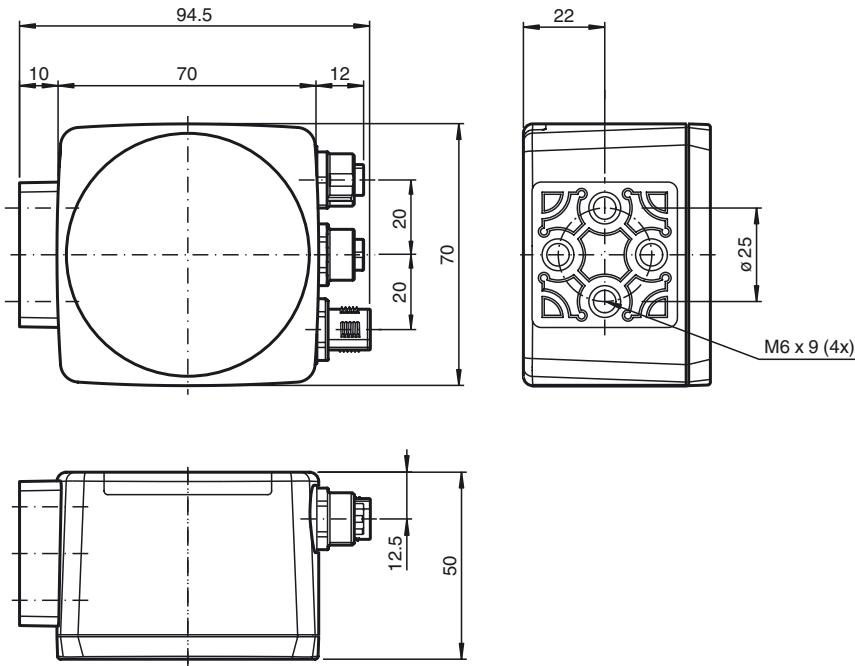

**Additional Information**

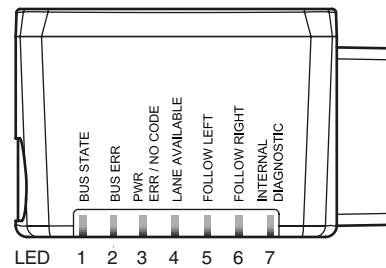
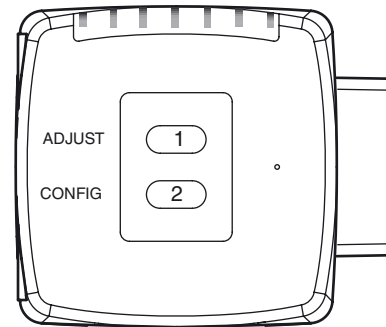

**Electrical Connection**

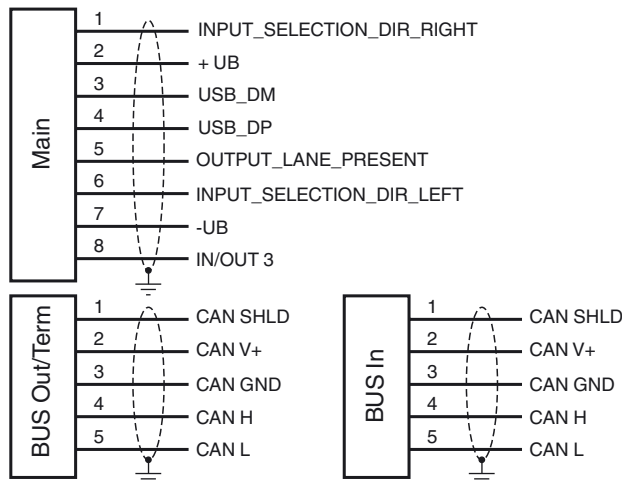

**Pinout**

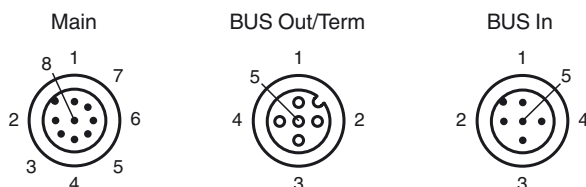

**General**

The PGV... reader forms part of the positioning system in the Pepperl+Fuchs incident light process. The reader's features include a camera module and an integrated illumination unit. The reader uses these features to detect a colored strip stuck to the floor to track the lane. The reader also detects control codes and position markers in the form of Data Matrix codes attached to a self-adhesive code tape. The code tape is usually mounted in a fixed position instead of the colored strip or parallel to the colored strip. The reader is located on the front of an automated guided vehicle and guides this vehicle along the colored strip.

**Accessories**

- PCV-SC12**  
Grounding clip for PCV system
- ICZ-TR-CAN/DN-V15**  
Terminal resistor for DeviceNet, CANopen
- PCV-LM25**  
Marker head for 25 mm code tape
- PCV-MB1**  
Mounting bracket for PCV\* read head
- V15-G-2M-PUR-CAN**  
DeviceNet/CANopen bus cable, M12, PUR cable, 5-pin
- V15-G-2M-PUR-CAN-V15-G**  
DeviceNet/CANOpen bus cable, M12 to M12, PUR cable 5-pin
- V15-G-5M-PUR-CAN-V15-G**  
DeviceNet/CANOpen bus cable, M12 to M12, PUR cable 5-pin
- V19-G-2M-PUR-ABG**  
Female cordset, M12, 8-pin, shielded, PUR cable
- V19-G-5M-PUR-ABG**  
Female cordset, M12, 8-pin, shielded, PUR cable
- V19-G-10M-PUR-ABG**  
Female cordset, M12, 8-pin, shielded, PUR cable
- PGV33M-CB19-BU**  
PGV color-tape blue
- PGV33M-CB19-GN**  
PGV color-tape green
- PGV33M-CB19-RD**  
PGV color-tape red

Release date: 2017-03-24 11:45 Date of issue: 2017-03-24 256089\_eng.xml

## Mounting and Commissioning

Mount the reader such that the optical surface of the device captures the optimum reading distance to the colored strip (see "Technical Data"). The stability of the mounting and the manner in which the vehicle is guided ensure that the reader is not operated outside of its depth of focus range. The colored strip must not leave the maximum reading window for the reader during this process. All readers can be adapted to optimally meet specific requirements through parameterization.

## Indicators and Operating Controls

The PGV... reader is equipped with seven indicator LEDs for carrying out visual function checks and rapid diagnostics. The reader is equipped with two buttons at the back for activating the alignment aid and parameterization mode.

### LEDs

LED	Color	Label	Description
1	Yellow	BUS STATE	CANopen communication active
2	Red	BUS ERR	CANopen communication error
3	Green/red	PWR ERR/NO CODE	Code detected/not detected, error
4	Yellow	LANE AVAILABLE	Lane available
5	Yellow	FOLLOW LEFT	"Follow left-hand lane" activated
6	Yellow	FOLLOW RIGHT	"Follow right-hand lane" activated
7	Red/green/yel- low	INTERNAL DIAGNOSTIC	Internal diagnostics

### External Parameterization

To parameterize the device externally, the parameterization code is required in the form of a Data Matrix containing the desired reader parameters. Data Matrix code cards detailing the step-by-step process for externally parameterizing the device are printed in the operating instructions for the reader.

The reader can be parameterized only within ten minutes of being switched on. If a key is pressed after ten minutes of the device being switched on, a visual signal is given by the LEDs (LED1, yellow/LED2, red/LED3, green/LED4, yellow/LED5, yellow/LED6, yellow, flashing for two seconds).

- The switchover from normal mode to parameterization mode is made by pressing button 2 on the back of the reader. To switch the device over, button 2 must be pressed and held for more than two seconds. LED4 then flashes.  
**Note:** Parameterization mode is exited automatically if the device is inactive for one minute. In this case, the reader reverts to normal mode and operates without the settings having been changed.
- Place the parameterization code in the field of vision of the camera module. After the parameterization code is detected, the green LED3 lights up for one second. If the parameterization code is invalid, LED3 lights up in red for two seconds.
- Briefly pressing button 2 will exit parameterization mode.