



BUSBAR SYSTEM, ACCESSORY CENTER-TO-CENTER DISTANCE 40, 60 MM TERMINAL RAIL THICKNESS: 100MM+DOUBLE T PROFILE FOR COPPER RAILS AND LAMINATED COPPER STRIPS ON BUSBARS 2X40X10MM ALSO FOR OBLONG CONNECTIONS

Model

product brand name	SENTRON
--------------------	---------

General Product Approval	Declaration of Conformity	Test Certificates
--------------------------	---------------------------	-------------------



CSA



GOST



UR



EG-Konf.

[Special Test Certificate](#)

Shipping Approval	other
-------------------	-------



GL



PRS



RINA

[other](#)

Further information

Information- and Downloadcenter (Catalogs, Brochures,...)

<http://www.siemens.com/lowvoltage/catalogs>

Industry Mall (Online ordering system)

<https://eb.automation.siemens.com/mall/en/WW/Catalog/Product/8US19412BB00>

Service&Support (Manuals, Certificates, Characteristics, FAQs,...)

<http://support.automation.siemens.com/WW/view/en/8US19412BB00/all>

Image database (product images, 2D dimension drawings, 3D models, device circuit diagrams, ...)

http://www.automation.siemens.com/bilddb/cax_en.aspx?mlfb=8US19412BB00

Cx-Online-Generator

<http://www.siemens.com/cax>

Tender specifications

<http://ausschreibungstexte.siemens.com/tiplv>

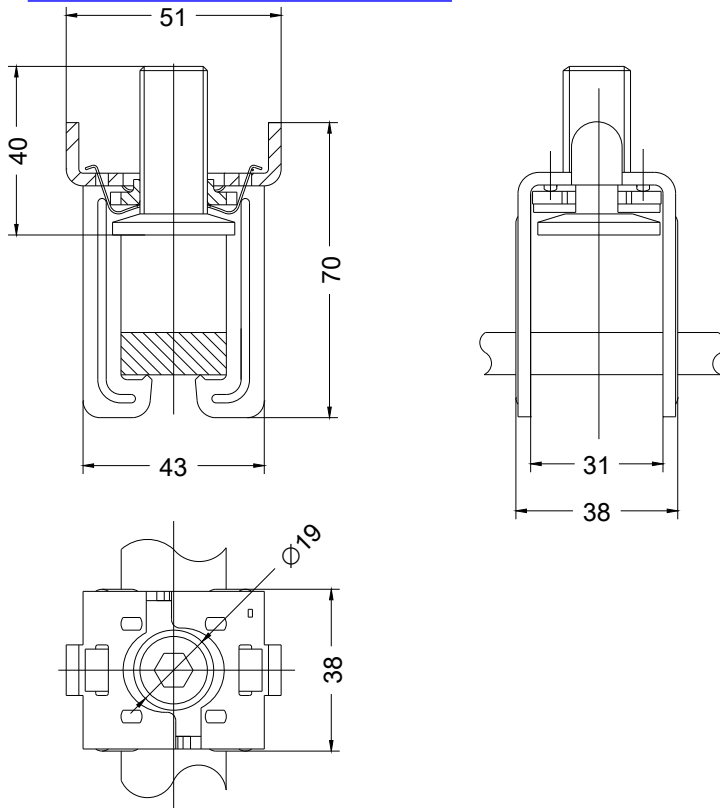

last modified:

11.03.2015