

MINISTART
Smart Motorstarter, For Modbus
UG 9411



Product Description

The smart motorstarter UG 9411 can be used for softstart, softstop, reversing and protecting 1 phase asynchronous motors. By measuring the line current a thermal model is used to calculate the motor temperature, and in the case of overtemperature the motor is disconnected. In addition also a thermo switch can be used. The reversing is done via relays. The relays are switched without current flow, this provides long service life.

Your Advantages

- Up to 6 functions in one device
 - Reversing anticlockwise,
 - Reversing clockwise
 - Softstart
 - Softstop
 - Motor protection
 - Phase failure monitoring
 - Communication monitoring
- Widely used measuring and automation protocol
- 80 % less space
- Simple and time-saving commissioning as well as user-friendly
- Operation through parameterization via modbus
- Hybrid relay combines benefits of relay technology with non-wearing semiconductor technology
- High availability by
 - Temperature monitoring of semiconductors
 - High withstand voltage up to 1500 V
 - Load free relay reversing function
 - Device overload
- Pluggable clamps
- TWIN- connection terminals to loop auxiliary supply and Bus

Features

- According to IEC/EN 60947-4-2
- Modbus RTU-interface
- To reverse 1-phase motors up to 50 ... 180 W or 180 W ... 1.1 kW at 230 V
- 1-phase softstart, softstop
- 3 potentiometer for setting the modbus adress and baud rate
- 5 LEDs for status indication
- Reversing with relays without current, softstart, softstop with thyristor
- Galvanic separation between control circuit and power circuit
- Width: 22.5 mm

Function Diagram

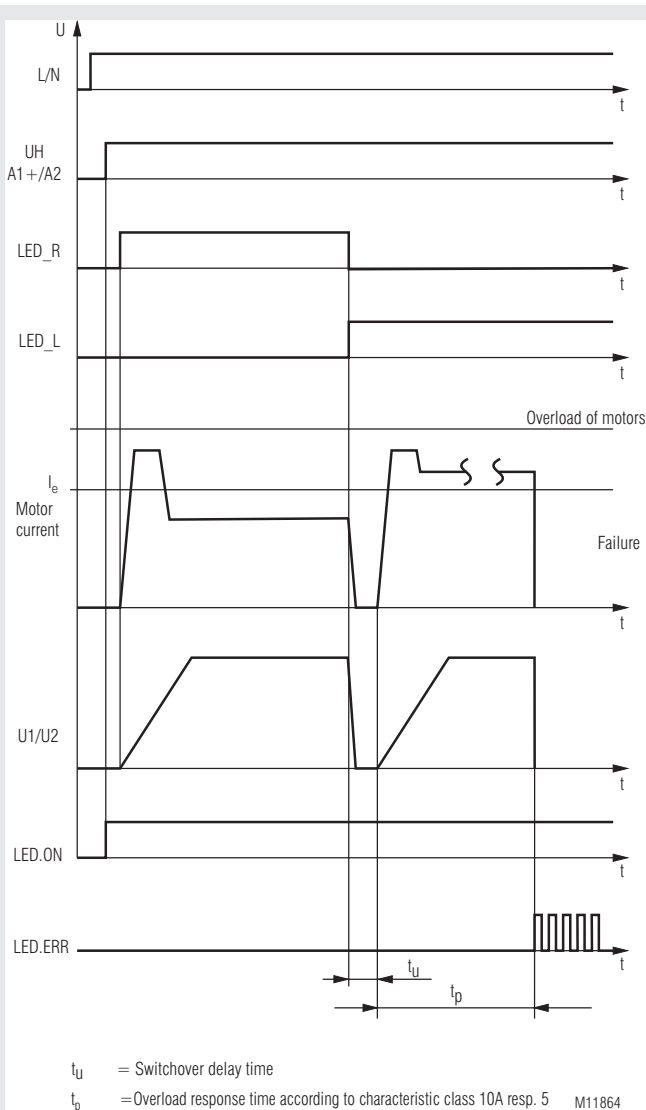

Approvals and Markings



Applications

- Reversing operation for door and gate controls, bridge drives and lifting applications
- Conveyor systems
- Actuating drives in process controls

Circuit Diagram

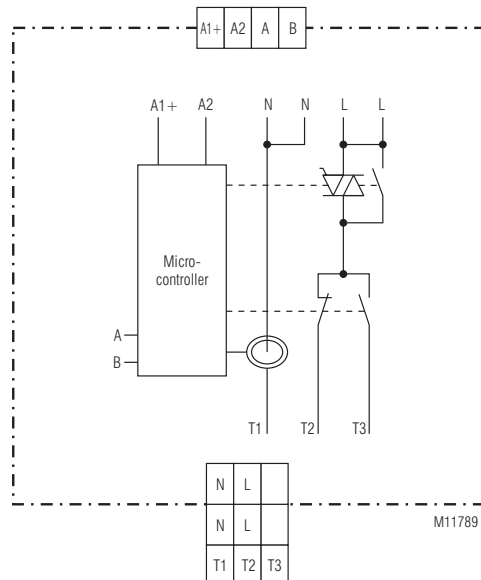

Connection Terminals	
Terminal designation	Signal description
A1 (+)	Auxiliary voltage + DC 24 V
A2	Auxiliary voltage 0 V
A	Modbus signal A
B	Modbus signal B
L	Phase connection L
N	Neutral
T1	Motor connection T1
T2	Motor connection T2
T3	Motor connection T3

Function

Softstart

The motor phase is controlled using thyristors, so that the motor current rises continuously. The starting torque behaves in the same way. This provides shock free starting and reduces mechanical failures. Starting time- and starting voltage can be adjusted via Modbus.

Softstop

The motor phases is controlled using thyristors, so that the motor current drops continuously. The motor torque behaves in the same way on run down. This provides shock free stopping and reduces mechanical failures. Stopping time and stopping voltage can be adjusted via Modbus.

Motorschutz

Motor protection

The thermal load of the motor is calculated using a thermal model. The current is measured in phase N. When the trigger value – stored in the trigger characteristics-, is reached, the motor is switched off and the device switches to fault 8.

The fault and motor leading can be acknowledged via Modbus.

Attention: The data of the thermal model is cleared through reset.



In this case, the user must provide adequate cooling time of the motor.

Phase failure monitoring

After connecting the auxiliary supply, the unit checks if the phases L / N is correct. If L or L / N phases are missing, the unit indicates fault 4. This fault can be reset via Modbus.

Communication monitoring

The communication monitoring controls the data transmission between Modbus-master and Modbus-slave using the registers "Timeout enable" and "Timeout time". It enables the Modbus-slave to switch off all outputs independently in the event of a communication failure. Further information can be found in the separate user manual Mode RTU.

Indicators

Green LED "On": Permanent on - Supply connected

Red LED "ERR": Flashing - Failure code of the device

Yellow LED "Bus": Flashing - When receiving or transmitting Modbus data

Yellow LED "L": Permanent on - Motor turns anti-clockwise
Flashing - Softstart or softstop active on anti-clockwise turn

Yellow LED "R": Permanent on - Motor turns clockwise
Flashing - Softstart or softstop active on clockwise turn

- Failure code :
- 1 - Overtemperature on semiconductors
 - 2 - Wrong mains frequency
 - 4 - Phase failure detected
 - 7 - Incorrect temperature measurement circuit
 - 8 - Motor protection has responded
 - 9 - Modbus communication failure
 - 10 - Checksum failure EEPROM

1*) - 10*) = Number of flashing pulses in sequence

Reset Function

By sending a reset command a reset can be operated via Modbus

Modbus RTU

For communication between motor controller and a supervising control the Modbus RTU protocol according to Specification V 1.1b3 is used.

Setting

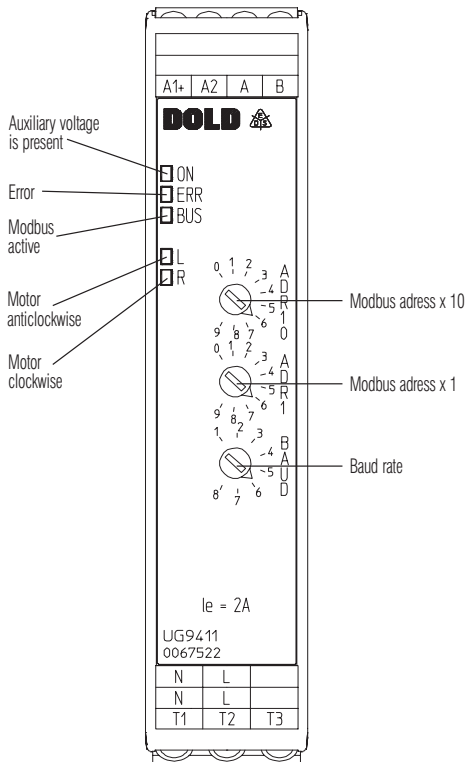

M11787_a

Position Potentiometer BAUD	1	2	3	4	5	6	7	8
Baud rate Baud	1200	2400	4800	9600	19200	38400	57600	115200
Response Time	< 50 ms	< 25 ms	< 12 ms	< 10 ms	< 5 ms	< 5 ms	< 5 ms	< 5 ms

Technical Data	
Nominal voltage L1/N:	AC 230 V ± 10%
Nominal frequency:	50 / 60 Hz , automatic detection
Auxiliary voltage:	DC 24 V ± 10%
Motor power:	1.5 A ... 7.0 adjustable via Modbus 0.3 A ... 2.0 A adjustable via Modbus
Operating mode:	
7.0 A:	AC 53a: 4-2: 100-30 IEC/EN 60947-4-2
2.0 A:	AC 53a: 4-2: 100-30 IEC/EN 60947-4-2
Measured nominal current:	7.0 A; 2.0 A
Surge current:	200 A (tp = 20 ms)
Load limit integral:	200 A²s (tp = 10 ms)
Peak reverse voltage:	1500 V
Overvoltage limiting:	AC 510 V
Leakage current in off state:	< 0.5 mA
Start / deceleration voltage:	30 ... 80 % adjustable via Modbus
Start / deceleration ramp:	0 ... 10 s adjustable via Modbus
Consumption:	2 W
Switchover delay time:	500 ms dependent of I _e
Switchover delay time:	150 ms
Start up delay for master tick:	Min. 25 ms
Release delay for master tick:	Min. 30 ms
Current measurement:	
7 A device:	AC 0.5 ... 25 A
2 A device:	AC 0.2 ... 10 A
Measuring accuracy:	± 5% of end of scale value
Measured value update time	
At 50 Hz:	100 ms
At 60 Hz:	83 ms
Motor protection	
Up to 6.9 A:	Class 10 A
6.9 to 7.0 A	Class 5
Electronically, with thermal memory	
Reset:	Manual via Modbus
Short circuit strength	
max. fuse rating:	25 A gG / gL IEC/EN 60947-5-1



Coordination Type!

Coordination type 1 according to IEC 60947-4-1: The engine control unit is defective following a short circuit and must be replaced.

General Data	
Operating mode:	Continuous operation
Operation:	0 ... + 65 °C (see derating curve) At an altitude of > 1000 m the maximum permissible temperature reduces by 0.5 °C / 100 m
Storage:	- 40 ... + 70 °C
Relative air humidity:	93 % at 40 °C
Altitude:	≤ 2000 m
Clearance and creepage distances	
Rated impuls voltage / pollution degree	
Motor voltage- control voltage:	6 kV / 2 IEC 60664-1
Motor voltage- Modbus:	6 kV / 2 IEC 60664-1
Overvoltage category:	III
EMC	
Electrostatic discharge:	8 kV (air) IEC/EN 61000-4-2
HF-irradiation	
80 MHz ... 1.0 GHz:	10 V / m IEC/EN 61000-4-3
1.0 GHz ... 2.5 GHz:	3 V / m IEC/EN 61000-4-3
2.5 GHz ... 2.7 GHz:	1 V / m IEC/EN 61000-4-3
Fast transients:	2 kV IEC/EN 61000-4-4
Surge voltages between	
Wires for power supply:	1 kV IEC/EN 61000-4-5
Between wire and ground:	2 kV IEC/EN 61000-4-5
HF wire guided:	10 V IEC/EN 61000-4-6
Voltage dips	IEC/EN 61000-4-11
Interference emission	
Wire guided:	Limit value class B IEC/EN 60947-4-2
Radio irradiation:	Limit value class B IEC/EN 60947-4-2
Harmonics:	EN 61000-3-2

Technical Data	
Degree of protection:	
Housing:	IP 40 IEC/EN 60529
Terminals:	IP 20 IEC/EN 60529
Vibration resistance:	Amplitude 0,35 mm Frequency 10 ... 55 Hz, IEC/EN 60068-2-6 0 / 065 / 04 IEC/EN 60068-1 DIN 46228-1/-2/-3/-4
Climate resistance:	
Wire connection:	
Removable terminal blocks	
Wire connection	
Phase voltage and motor pluggable screw terminal (S):	0.25 ... 2.5 mm ² solid or 0.25 ... 2.5 mm ² stranded ferruled
Wire connection:	
Bus and auxiliary supply pluggable Twin-cage-clamp-terminal (PT):	0.25 ... 1.5 mm ² solid or 0.25 ... 1.5 mm ² stranded ferruled
Insulation of wires or sleeve length:	8 mm
Fixing torque:	0.5 ... 0.6 Nm
Mounting:	DIN rail IEC/EN 60715
Weight:	220 g
Dimensions	
Width x height x depth:	22.5 x 105 x 120.3 mm

Standard Types	
UG 9411PM AC 230 V 50/60 Hz 7.0 A	
Article number:	0067523
• Nominal voltage:	AC 230 V
• Nominal motor current:	7.0 A
• Modbus RTU	
• Adjustable baud rate	
• Width:	22.5 mm
UG 9411PM AC 230 V 50/60 Hz 2.0 A	
Article number:	0067522
• Nominal voltage:	AC 230 V
• Nominal motor current:	2.0 A
• Modbus RTU	
• Adjustable baud rate	
• Width:	22.5 mm

Characteristics

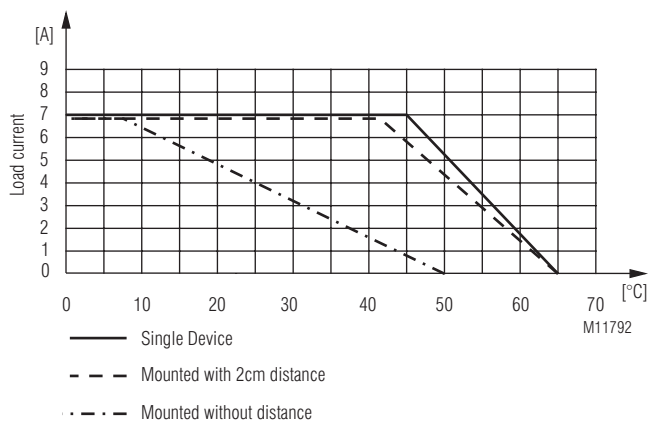

Derating curve:
Rated continuous current depending on ambient temperature and distance
Enclosure without ventilation slots

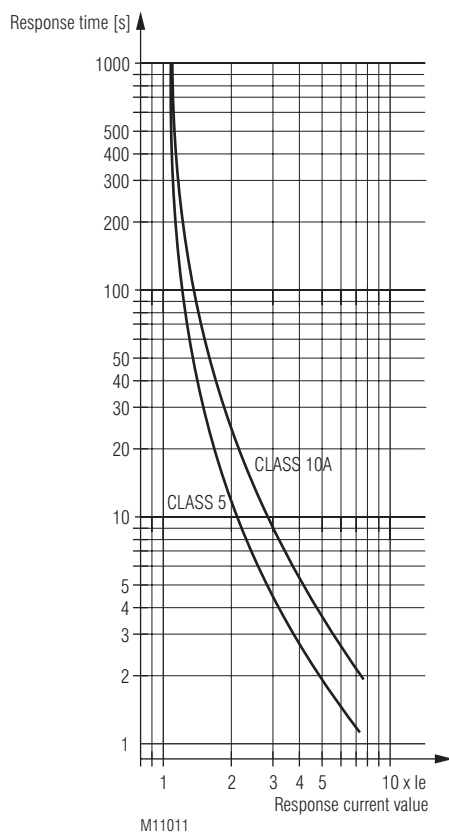

Trigger characteristics
Motor overload protection

Setting Facilities

Potentiometer ADR10: - Unit adress x 10

Potentiometer ADR1: - Unit adress x 1

Potentiometer BAUD: - Baud rate

The module address and baud rate is only read after connecting the auxiliary supply!

Group fusing

Several motor starters can be wired in parallel on the supply side. Please make sure, that the total current cannot exceed 16 A. If several starters are use together and require more than 16 A, groups have to be split up for max 16 A.

Set-up Procedure

1. Connect motor and device according to application example. The 3 phases must be connected in correct sequence, wrong phase sequence will lead to failure (see failure code)
2. Setting unit adress and baud rate via potentiometer.
3. Power up the unit.
4. Parametrization via Modbus
5. At correct setting, the motor should ramp up continuously to full speed.

! Safety Notes



Installation Error!

- For engine control units, the minimum loads indicated in the data sheet must be observed.
- The use of capacitive loads can lead to the destruction of switching components of the motor control unit. Do not operate capacitive loads on the motor control unit.
- To ensure that the motor is switched off if the Modbus communication fails, the communication must be monitored using the time-out function.



Although the motor is at standstill, it is not galvanically separated from the mains.



Functional error!

- **Danger to life, risk of serious injuries or property damage.**
It must be ensured that the motor start signal is removed before the reset, otherwise the motor will start again.

Application Example

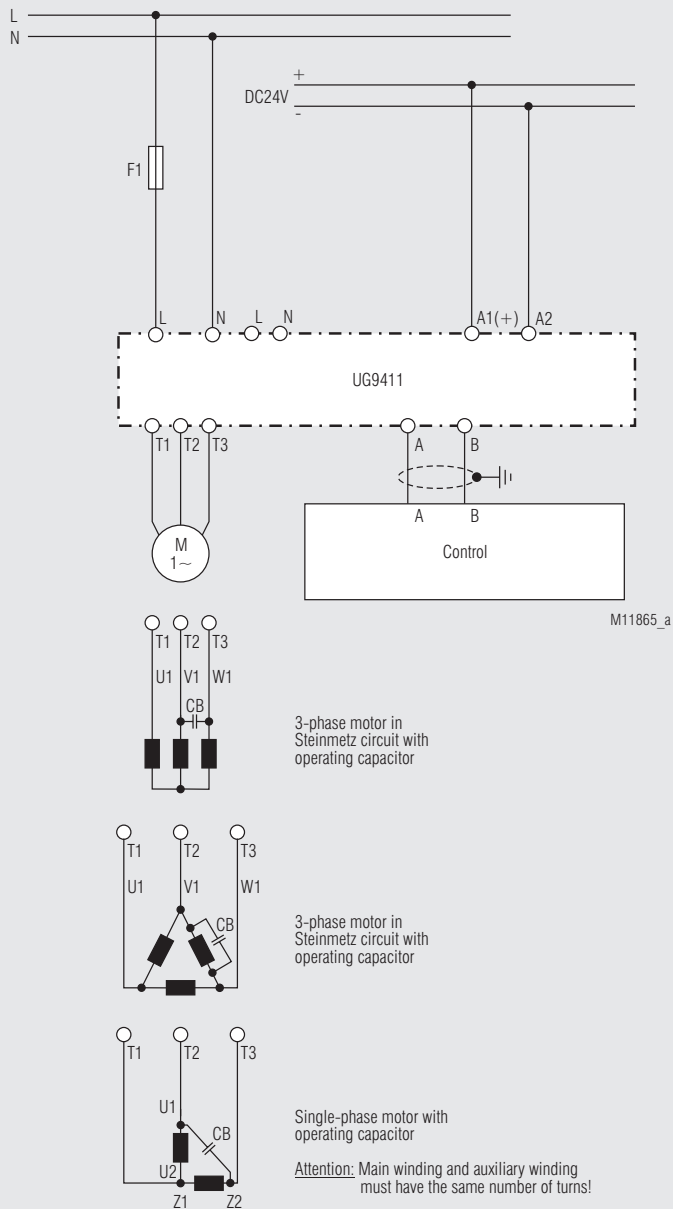

Motor control with UG 9411 and PLC via Modbus

Bus Interface

Protocol	Modbus Seriell RTU
Address	1 bis 99
Baud rate	1200, 2400, 4800, 9600, 19200, 38400, 57600, 115200 Baud
Data bit	8
Stop bit	2
Parity	None

More information about the interface, wiring rules, device identification and communication monitoring can be found in the Modbus user manual.

Function-Codes

At UG 9411 the following function codes are implemented:

Function-Code	Name	Description
0x03	Read Holding Register	Device parameter read word by word
0x04	Read Input Register	Actual values read word by word
0x05	Write Single Coil	Outputs write individually
0x06	Write Single Register	Device parameter write word by word
0x10	Write Multiple Register	Device parameter write in blocks

Device configuration

If required the device configuration data can be saved permanently by setting the the Bit "Write configuration to EEPROM". The data is copied from the EEPROM to the relevant register when connecting the auxiliary voltage. As the numbers of write cycles of an EEPROM are limited, the writing must not be done in cycles. In addition it is not possible to receive modbus telegrams during a period of 50 ms while writing the EEPROM.

Parameter table

Every slave owns an output- configuration- and actual value table. In these tables it is defined under which address the parameters can be found.

Single Coils (Control signals):

Register-Address	Protocol-Address	Name	Value range	Description	Data type	Access rights
1	0	RunRight	0x0000 0xFF00	Motor turns right off Motor turns right on	BIT	write
2	1	RunLeft	0x0000 0xFF00	Motor turns left off Motor turns left on	BIT	write
3	2	Reset	0x0000 0xFF00	No function Device reset	BIT	write
4	3	Write configuration to EEPROM	0x0000 0xFF00	No function Save parameter	BIT	write

Input Register (Device state and measuring values):

Register-Address	Protocol-Address	Name	Value range	Description	Data type	Access rights
30001	0	State word 1 Device failure	0 ... 10	0: No failure 1: Overtemperature LT 2: Wrong frequency 3: Phase reversal 4: Phase failure 5: 6: 7: Temperatur circuit fault 8: Motor protection device actuated 9: Communication fault Modbus 10: Checksum failure EEPROM	UINT16	reading
30002	1	State word 2 State of device	0 ... 6	0: Device initialize 1: Wait for start 2: Softstart ramp 3: Clockwise On 4: Anti-clockwise On 5: Softstop ramp 6: Device in error mode	UINT16	reading
30003	2	Actual motor current	0 ... 3000	Actual motor current in 1/100 A	UINT16	reading
30004	3	Motor load	0 ... 100	Motor load in % from rated motor power	UINT16	reading

Holding Register (Device configuration):

Register-Address	Protocol-Address	Name	Value range	Initial value	Description	Data type	Access rights
40001	0	Control word 1	0 ... 2	0	Bit 0 = Reset Bit 1 = Write configuration to EEPROM	UINT16	write / reading
40002	1	Control word 2	0 ... 2	0	Bit 0 = RunRight Bit 1 = RunLeft	UINT16	write / reading
40003	2	I _n Typ 2A I _n Typ 7A *)	30 ... 200 150 ... 700	50	Nominal motor current in 1/100 A	UINT16	write / reading
40004	3	U _{on} *)	30 ... 80	30	Softstart voltage in % from nominal voltage	UINT16	write / reading
40005	4	T _{on} *)	0 ... 100	100	Softstart ramp time in 1/10 s	UINT16	write / reading
40006	5	U _{off} *)	80 ... 30	30	Softstop voltage in % from nominal voltage	UINT16	write / reading
40007	6	T _{off} *)	0 ... 100	100	Softstop ramp time in 1/10 s	UINT16	write / reading
40008	7	Timeout release	0 ... 1	0	0 = Disable 1 = Enable	UINT16	write / reading
40009	8	Timeout	1000 ... 10000	1000	Timeout value in ms	UINT16	write / reading

*) Parameters can be stored permanently in the EEPROM by setting the Bit "Write configuration to EEPROM"

