

FEATURES

- Fast access time : 35/55/70ns
- Low power consumption:
 Operating current : 20/15/10mA (TYP.)
 Standby current : 1 μ A (TYP.) LL-version
- Single 2.7~5.5V power supply
- All inputs and outputs TTL compatible
- Fully static operation
- Tri-state output
- Data retention voltage : 1.5V (MIN.)
- **Lead free and green package available**
- Package : 28-pin 600 mil PDIP
 28-pin 330 mil SOP
 28-pin 8mm x 13.4mm STSOP
 28-pin 300 mil Skinny P-DIP

GENERAL DESCRIPTION

The LY6264 is a 65,536-bit low power CMOS static random access memory organized as 8,192 words by 8 bits. It is fabricated using very high performance, high reliability CMOS technology. Its standby current is stable within the range of operating temperature.

The LY6264 is well designed for very low power system applications, and particularly well suited for battery back-up nonvolatile memory application.

The LY6264 operates from a single power supply of 2.7~5.5V and all inputs and outputs are fully TTL compatible

PRODUCT FAMILY

Product Family	Operating Temperature	Vcc Range	Speed	Power Dissipation	
				Standby(Isb1, TYP.)	Operating(Icc, TYP.)
LY6264	0 ~ 70°C	2.7 ~ 5.5V	35/55/70ns	1 μ A(LL)	20/15/10mA
LY6264(E)	-20 ~ 80°C	2.7 ~ 5.5V	35/55/70ns	1 μ A(LL)	20/15/10mA
LY6264(I)	-40 ~ 85°C	2.7 ~ 5.5V	35/55/70ns	1 μ A(LL)	20/15/10mA

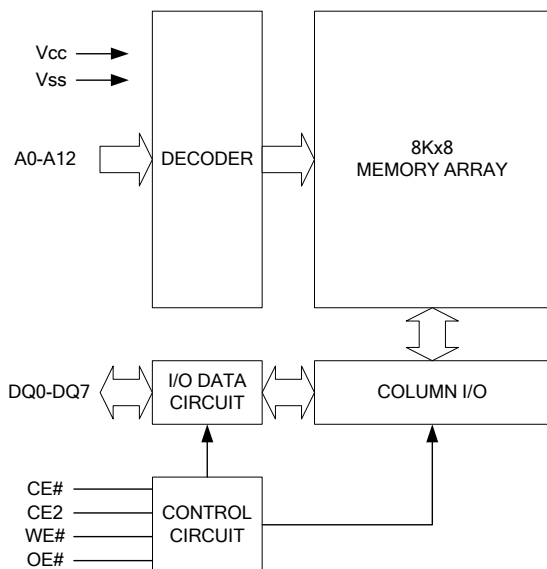
FUNCTIONAL BLOCK DIAGRAM

PIN DESCRIPTION

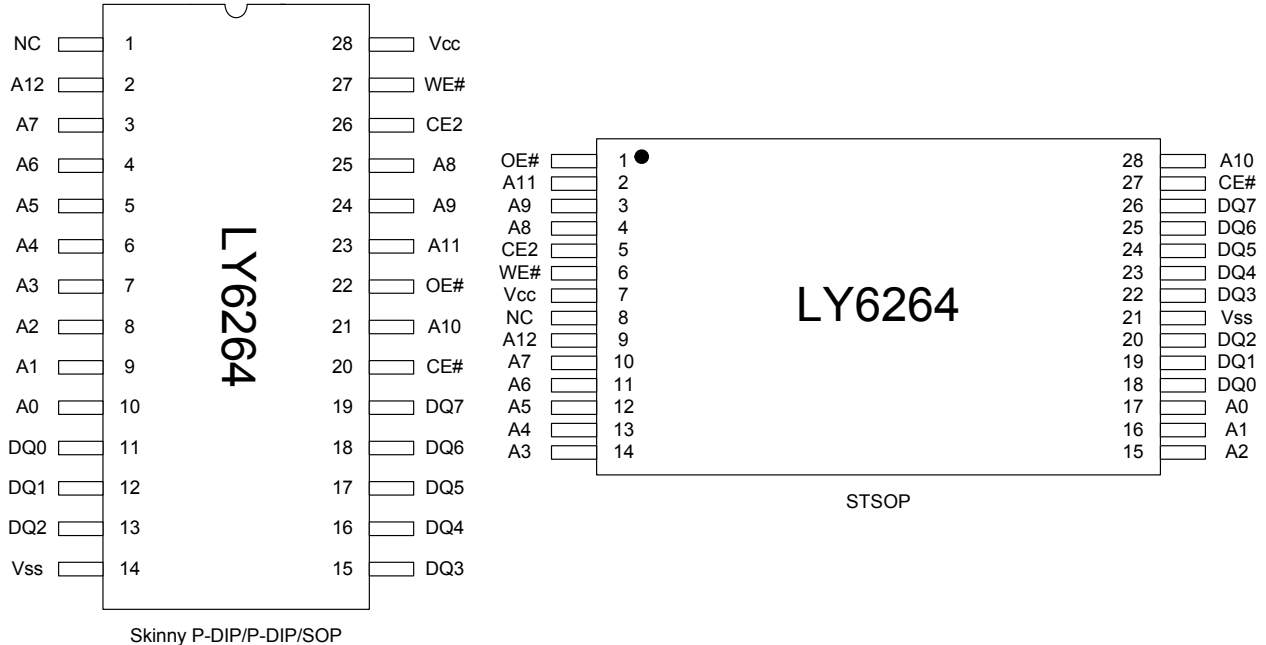
SYMBOL	DESCRIPTION
A0 - A12	Address Inputs
DQ0 - DQ7	Data Inputs/Outputs
CE#, CE2	Chip Enable Inputs
WE#	Write Enable Input
OE#	Output Enable Input
Vcc	Power Supply
Vss	Ground
NC	No Connection

PIN CONFIGURATION

ABSOLUTE MAXIMUM RATINGS*

PARAMETER	SYMBOL	RATING	UNIT
Terminal Voltage with Respect to V _{SS}	V _{TERM}	-0.5 to 7.0	V
Operating Temperature	T _A	0 to 70(C grade)	°C
		-20 to 80(E grade)	
		-40 to 85(I grade)	
Storage Temperature	T _{STG}	-65 to 150	°C
Power Dissipation	P _D	1	W
DC Output Current	I _{OUT}	50	mA
Soldering Temperature (under 10 sec)	T _{SOLDER}	260	°C

*Stresses greater than those listed under "Absolute Maximum Ratings" may cause permanent damage to the device. This is a stress rating only and functional operation of the device or any other conditions above those indicated in the operational sections of this specification is not implied. Exposure to the absolute maximum rating conditions for extended period may affect device reliability.

TRUTH TABLE

MODE	CE#	CE2	OE#	WE#	I/O OPERATION	SUPPLY CURRENT
Standby	H	X	X	X	High-Z	I _{SB} , I _{SB1}
	X	L	X	X	High-Z	I _{SB} , I _{SB1}
Output Disable	L	H	H	H	High-Z	I _{CC} , I _{CC1}
Read	L	H	L	H	D _{OUT}	I _{CC} , I _{CC1}
Write	L	H	X	L	D _{IN}	I _{CC} , I _{CC1}

Note: H = V_{IH}, L = V_{IL}, X = Don't care.

**DC ELECTRICAL CHARACTERISTICS**

PARAMETER	SYMBOL	TEST CONDITION	MIN.	TYP. ^⑤	MAX.	UNIT
Supply Voltage	V _{CC}		2.7	3.3	5.5	V
Input High Voltage	V _{IH} ^①		2.4	-	V _{CC} +0.5	V
Input Low Voltage	V _{IL} ^②	V _{CC} =2.7~3.6V	-0.5	-	0.6	V
		V _{CC} =4.5~5.5V	-0.5	-	0.8	V
Input Leakage Current	I _{LI}	V _{CC} ≥ V _{IN} ≥ V _{SS}	-1	-	1	μA
Output Leakage Current	I _{LO}	V _{CC} ≥ V _{OUT} ≥ V _{SS} , Output Disabled	-1	-	1	μA
Output High Voltage	V _{OH}	I _{OH} = -1mA	2.4	3.0	-	V
Output Low Voltage	V _{OL}	I _{OL} = 2mA	-	-	0.4	V
Average Operating Power supply Current	I _{CC}	Cycle time = Min. CE# = V _{IL} and CE2 = V _{IH} , I _{I/O} = 0mA	-35	20	50	mA
			-55	15	45	mA
			-70	10	40	mA
	I _{CC1}	Cycle time = 1μs CE# ≤ 0.2V and CE2 ≥ V _{CC} -0.2V, I _{I/O} = 0mA other pins at 0.2V or V _{CC} -0.2V	-	3	10	mA
Standby Power Supply Current	I _{SB}	CE# = V _{IH} or CE2 = V _{IL}	-	1	3	mA
	I _{SB1}	CE# ≥ V _{CC} -0.2V or CE2 ≤ 0.2V	V _{CC} =2.7~3.6V	1	20 ^{④⑥}	μA
			V _{CC} =2.7~5.5V	1	50 ^④	μA

Notes:

- V_{IH}(max) = V_{CC} + 3.0V for pulse width less than 10ns.
- V_{IL}(min) = V_{SS} - 3.0V for pulse width less than 10ns.
- Over/Undershoot specifications are characterized, not 100% tested.
- 10μA for special request
- Typical values are included for reference only and are not guaranteed or tested.
Typical values are measured at V_{CC} = V_{CC}(TYP.) and T_A = 25°C
- This value is measured at V_{CC} = 3.6V.

CAPACITANCE (T_A = 25°C, f = 1.0MHz)

PARAMETER	SYMBOL	MIN.	MAX	UNIT
Input Capacitance	C _{IN}	-	6	pF
Input/Output Capacitance	C _{I/O}	-	8	pF

Note : These parameters are guaranteed by device characterization, but not production tested.

AC TEST CONDITIONS

Input Pulse Levels	0.2V to V _{CC} - 0.2V
Input Rise and Fall Times	3ns
Input and Output Timing Reference Levels	1.5V
Output Load	C _L = 50pF + 1TTL, I _{OH} /I _{OL} = -1mA/2mA



AC ELECTRICAL CHARACTERISTICS

(1) READ CYCLE

PARAMETER	SYM.	LY6264-35		LY6264-55		LY6264-70		UNIT
		MIN.	MAX.	MIN.	MAX.	MIN.	MAX.	
Read Cycle Time	t _{RC}	35	-	55	-	70	-	ns
Address Access Time	t _{AA}	-	35	-	55	-	70	ns
Chip Enable Access Time	t _{ACE}	-	35	-	55	-	70	ns
Output Enable Access Time	t _{OE}	-	25	-	30	-	35	ns
Chip Enable to Output in Low-Z	t _{CLZ} *	10	-	10	-	10	-	ns
Output Enable to Output in Low-Z	t _{OLZ} *	5	-	5	-	5	-	ns
Chip Disable to Output in High-Z	t _{CHZ} *	-	15	-	20	-	25	ns
Output Disable to Output in High-Z	t _{OHZ} *	-	15	-	20	-	25	ns
Output Hold from Address Change	t _{OH}	10	-	10	-	10	-	ns

(2) WRITE CYCLE

PARAMETER	SYM.	LY6264-35		LY6264-55		LY6264-70		UNIT
		MIN.	MAX.	MIN.	MAX.	MIN.	MAX.	
Write Cycle Time	t _{WC}	35	-	55	-	70	-	ns
Address Valid to End of Write	t _{AW}	30	-	50	-	60	-	ns
Chip Enable to End of Write	t _{CW}	30	-	50	-	60	-	ns
Address Set-up Time	t _{AS}	0	-	0	-	0	-	ns
Write Pulse Width	t _{WP}	25	-	45	-	55	-	ns
Write Recovery Time	t _{WR}	0	-	0	-	0	-	ns
Data to Write Time Overlap	t _{DW}	20	-	25	-	30	-	ns
Data Hold from End of Write Time	t _{DH}	0	-	0	-	0	-	ns
Output Active from End of Write	t _{OW} *	5	-	5	-	5	-	ns
Write to Output in High-Z	t _{WHZ} *	-	15	-	20	-	25	ns

*These parameters are guaranteed by device characterization, but not production tested.

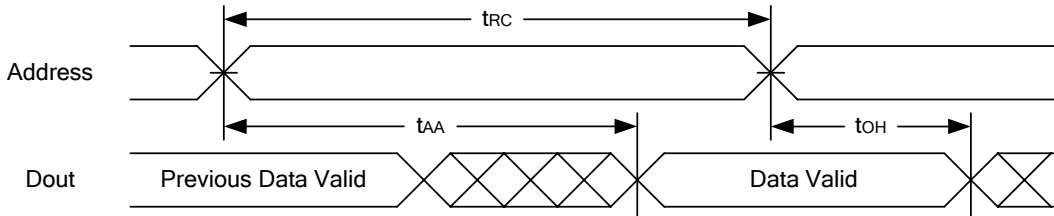
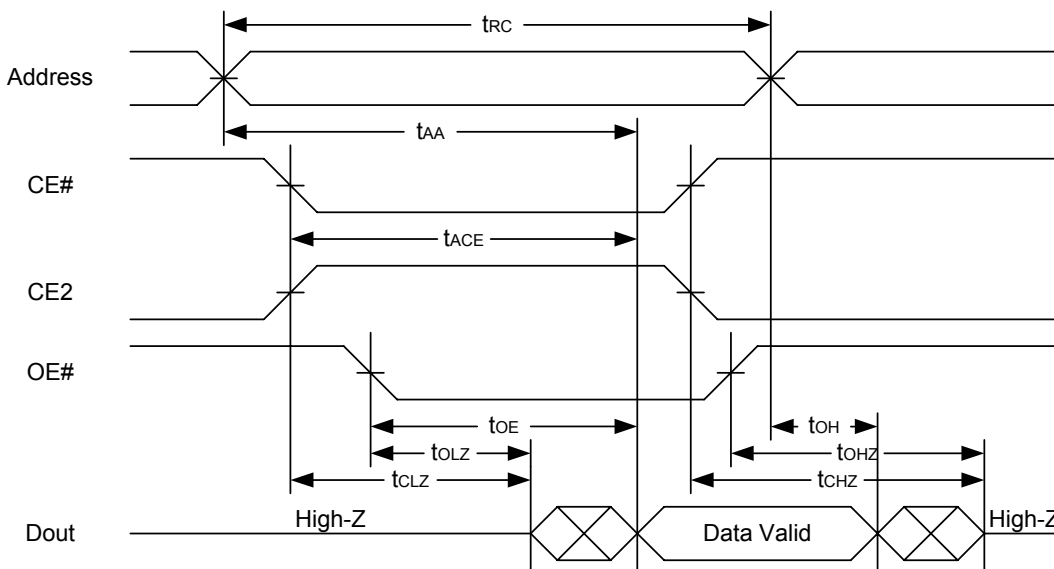
TIMING WAVEFORMS
READ CYCLE 1 (Address Controlled) (1,2)

READ CYCLE 2 (CE# and CE2 and OE# Controlled) (1,3,4,5)

Notes :

1. WE# is high for read cycle.
2. Device is continuously selected OE# = low, CE# = low, CE2 = high.
3. Address must be valid prior to or coincident with CE# = low, CE2 = high; otherwise tAA is the limiting parameter.
4. tCLZ, tOLZ, tCHZ and tOHZ are specified with CL = 5pF. Transition is measured ±500mV from steady state.
5. At any given temperature and voltage condition, tCHZ is less than tCLZ, tOHZ is less than tOLZ.

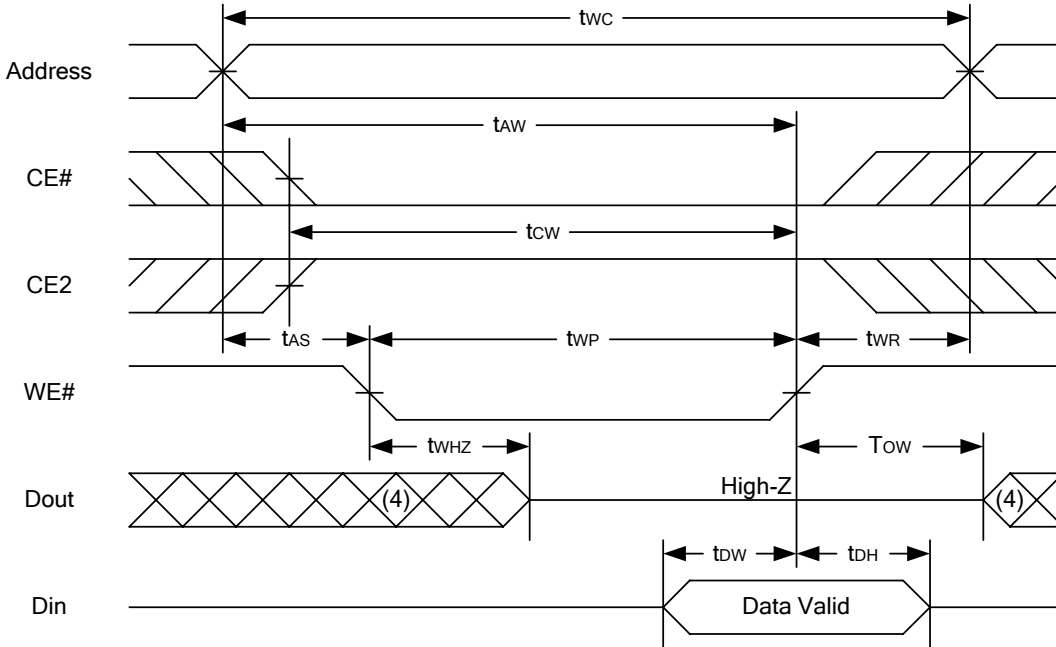

WRITE CYCLE 1 (WE# Controlled) (1,2,3,5,6)



WRITE CYCLE 2 (CE# and CE2 Controlled) (1,2,5,6)

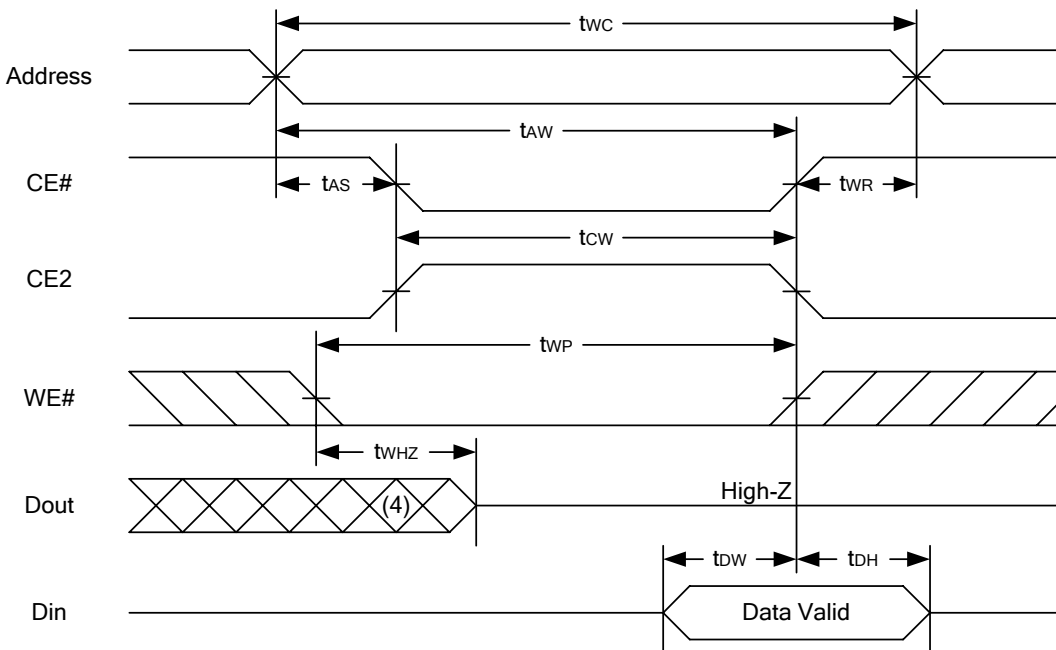

Notes :

1. WE#, CE# must be high or CE2 must be low during all address transitions.
2. A write occurs during the overlap of a low CE#, high CE2, low WE#.
3. During a WE#-controlled write cycle with OE# low, twp must be greater than twhz + tdw to allow the drivers to turn off and data to be placed on the bus.
4. During this period, I/O pins are in the output state, and input signals must not be applied.
5. If the CE# low transition and CE2 high transition occurs simultaneously with or after WE# low transition, the outputs remain in a high impedance state.
6. tow and twhz are specified with CL = 5pF. Transition is measured ±500mV from steady state.

DATA RETENTION CHARACTERISTICS

PARAMETER	SYMBOL	TEST CONDITION	MIN.	TYP.	MAX.	UNIT
Vcc for Data Retention	V _{DR}	CE# ≥ V _{CC} - 0.2V or CE2 ≤ 0.2V	1.5	-	5.5	V
Data Retention Current	I _{DR}	V _{CC} = 1.5V CE# ≥ V _{CC} - 0.2V or CE2 ≤ 0.2V	-	0.5	20	μA
Chip Disable to Data Retention Time	t _{CDR}	See Data Retention Waveforms (below)	0	-	-	ns
Recovery Time	t _R		t _{RC*}	-	-	ns

 t_{RC*} = Read Cycle Time

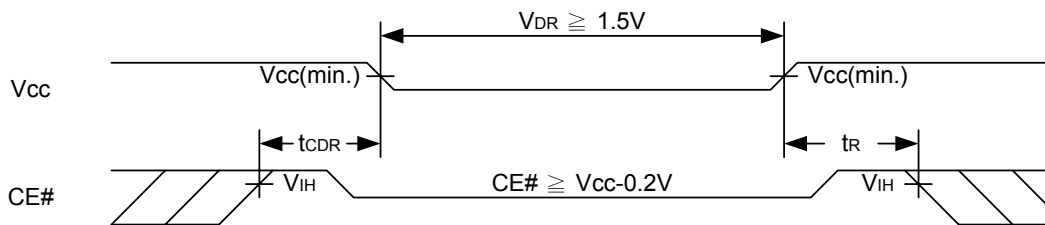
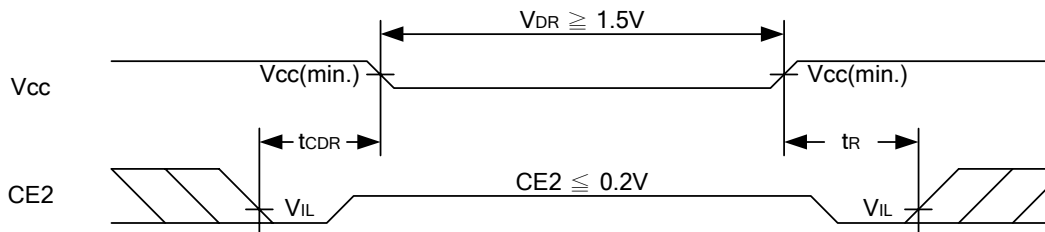
DATA RETENTION WAVEFORM
Low Vcc Data Retention Waveform (1) (CE# controlled)

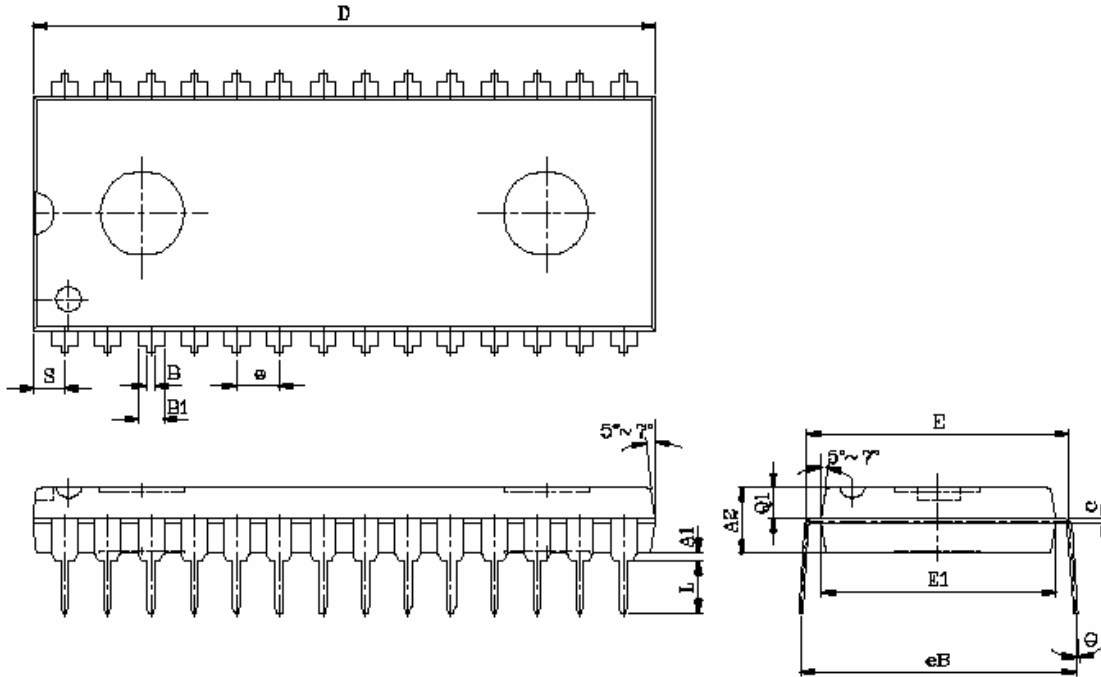
Low Vcc Data Retention Waveform (2) (CE2 controlled)

PACKAGE OUTLINE DIMENSION
28 pin 600 mil PDIP Package Outline Dimension

SYM.	UNIT	INCH.(BASE)	MM(REF)
A1		0.010 (MIN)	0.254 (MIN)
A2		0.150±0.005	3.810±0.127
B		0.020 (MAX)	0.508(MAX)
B1		0.055 (MAX)	1.397(MAX)
c		0.012 (MAX)	0.304 (MAX)
D		1.430 (MAX)	36.322 (MAX)
E		0.6 (TYP)	15.24 (TYP)
E1		0.52 (MAX)	13.208 (MAX)
e		0.100 (TYP)	2.540(TYP)
eB		0.625 (MAX)	15.87 (MAX)
L		0.180(MAX)	4.572(MAX)
S		0.06 (MAX)	1.524 (MAX)
Q1		0.08(MAX)	2.032(MAX)
Θ		15°(MAX)	15°(MAX)

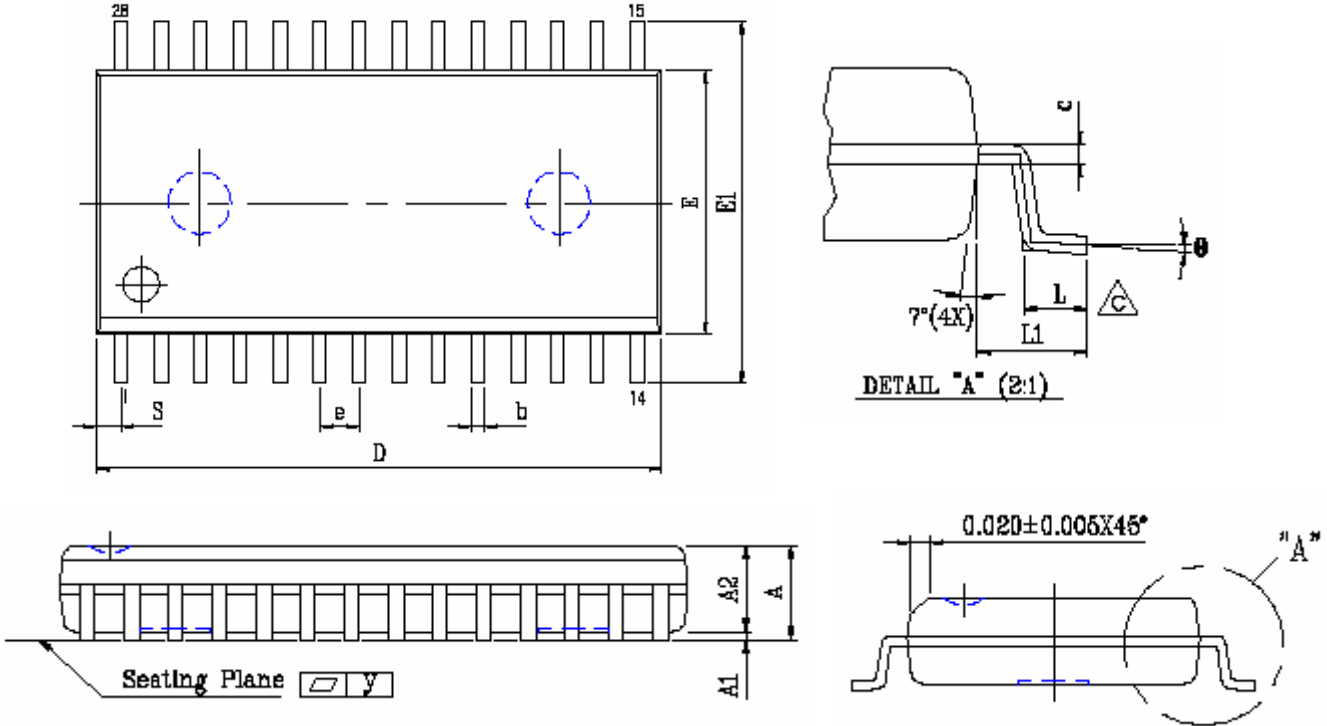

28 pin 330 mil SOP Package Outline Dimension



SYM.	UNIT	
	INCH(BASE)	MM(REF)
A	0.120 (MAX)	3.048 (MAX)
A1	0.002(MIN)	0.05(MIN)
A2	0.098±0.005	2.489±0.127
b	0.016 (TYP)	0.406(TYP)
c	0.010 (TYP)	0.254(TYP)
D	0.728 (MAX)	18.491 (MAX)
E	0.340 (MAX)	8.636 (MAX)
E1	0.465±0.012	11.811±0.305
e	0.050 (TYP)	1.270(TYP)
L	0.05 (MAX)	1.270 (MAX)
L1	0.067±0.008	1.702 ±0.203
S	0.047 (MAX)	1.194 (MAX)
y	0.003(MAX)	0.076(MAX)
θ	0°~10°	0°~10°

28 pin 8mm x 13.4mm STSOP Package Outline Dimension

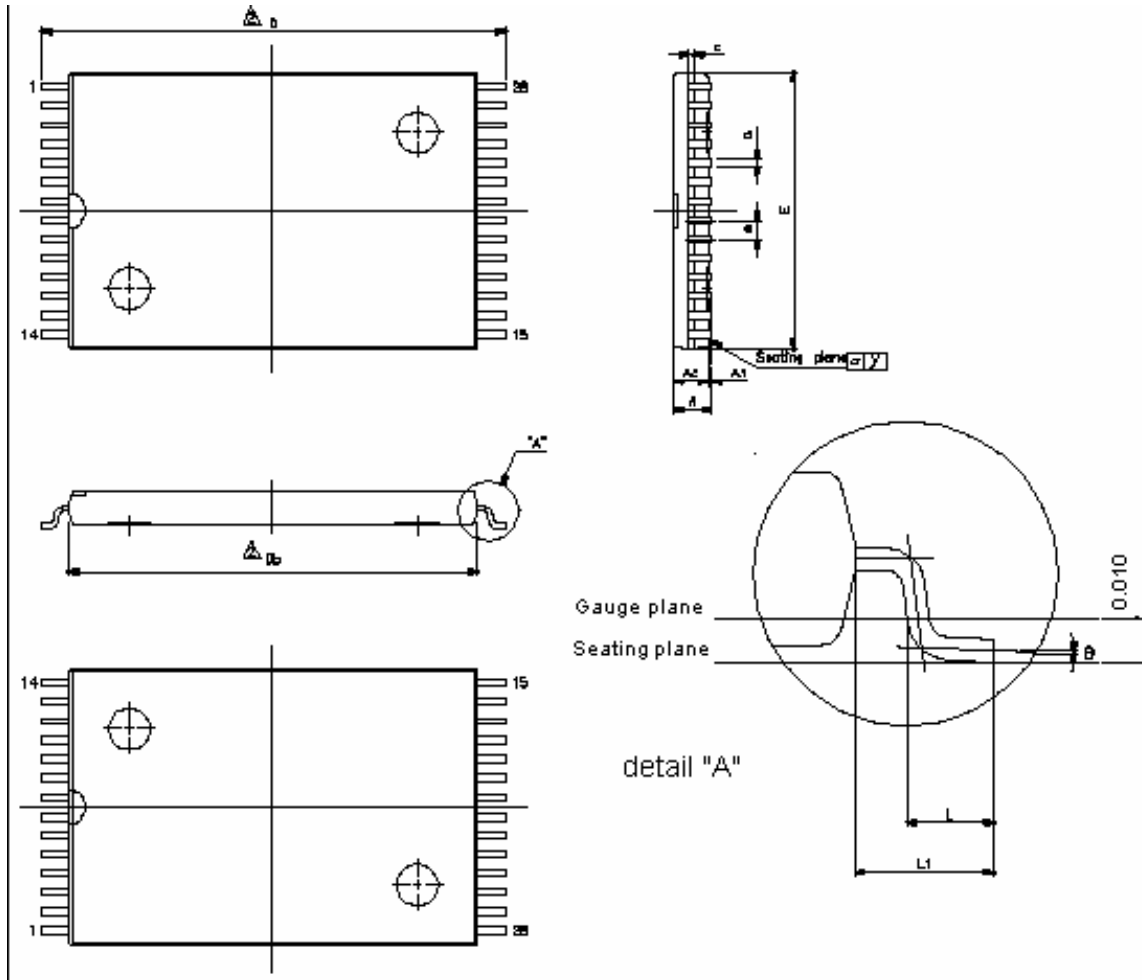

SYM.	UNIT	INCH(BASE)	MM(REF)
A		0.047 (MAX)	1.20 (MAX)
A1		0.004±0.002	0.10±0.05
A2		0.039±0.002	1.00±0.05
b		0.006 (TYP)	0.15(TYP)
c		0.010 (TYP)	0.254(TYP)
Db		0.465±0.004	11.80±0.10
E		0.315±0.004	8.00±0.10
e		0.022 (TYP)	0.55(TYP)
D		0.528±0.008	13.40±0.20
L		0.020±0.004	0.50±0.10
L1		0.0315±0.004	0.80±0.10
y		0.08(MAX)	0.003(MAX)
θ		0°~5°	0°~5°

Note : E dimension is not including end flash. The total of both sides' end flash is not above 0.3mm.



28 pin 300 mil PDIP Package Outline Dimension

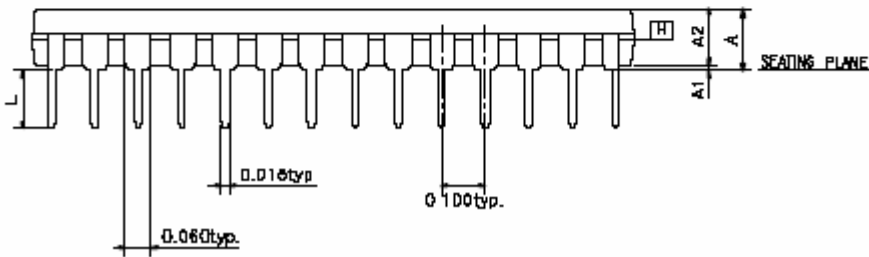
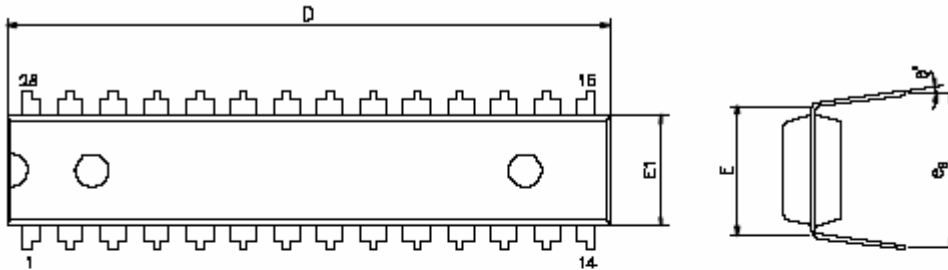

SYMBOLS	MIN.	NOR.	MAX.
A	—	—	0.210
A1	0.015	—	—
A2	0.125	0.130	0.135
D	1.385	1.390	1.400
E	0.310 BSC		
E1	0.283	0.288	0.293
L	0.115	0.130	0.150
eB	0.330	0.350	0.370
θ°	0	7	15

UNIT : INCH

NOTE:

1. JEDEC OUTLINE : MS-D15 AH



ORDERING INFORMATION

LY6264 V W - XX YY Z

Z : Temperature Range
Blank : (Commercial) 0°C ~ 70°C
E : (Extended) -20°C ~ 80°C
I : (Industrial) -40°C ~ 85°C

YY : Power Type
LL : Ultra Low Power

XX : Access Time(Speed)

W : Lead Information
N : Normal
L : Lead Free

V : Package Type
P : 28-pin 600 mil P-DIP
S : 28-pin 330 mil SOP
R : 28-pin 8 mm x 13.4 mm STSOP
D : 28-pin 300 mil P-DIP



THIS PAGE IS LEFT BLANK INTENTIONALLY.