

## General Description

The MAX17245 evaluation kit (EV kit) demonstrates the MAX17245 high-voltage, current-mode step-down converter with low operating current. The EV kit operates over a wide 6V to 36V input range and the output is set for 5V at 3.5A.

The EV kit comes with the MAX17245ETESA+ installed.

## Features

- Wide 6V to 36V Input Supply Range
- Forced-PWM or Skip-Mode Operation
- Configurable Switching Frequency
- Current-Mode Controller with Force-PWM and Skip Modes
- 84% Peak Efficiency at 12V Input in Skip-Mode
- 88% Peak Efficiency at 12V Input in Forced-PWM
- FSYNC Input and Power-Good Output
- Proven 4-Layer 2oz Copper PCB Layout
- Demonstrates 1065mil x 795mil Solution Size
- Fully Assembled and Tested

## Quick Start

### Required Equipment

- MAX17245 EV kit
- 14V, 3A DC power supply
- Electronic load capable of 3.5A
- Digital voltmeter (DVM)

### Procedure

The EV kit is fully assembled and tested. Follow the steps below to verify board operation. **Caution: Do not turn on supplies until all connections are completed.**

- 1) Verify that jumpers JU1 and JU2 are in their default positions, as shown in [Table 1](#) and [Table 2](#).
- 2) Connect the power supply between the EXT\_VBAT and nearest PGND banana jacks.
- 3) Connect the 3.5A electronic load between the OUT and nearest PGND banana jacks.
- 4) Connect the DVM between the OUT and nearest PGND banana jacks.

- 5) Turn on the power supply.
- 6) Enable the electronic load.
- 7) Verify that the voltage at the OUT test point is approximately 5V.

*Note: When a high input voltage or a high load current is applied continuously, an external cooling fan may be required to prevent MAX17245 from shutting down due to overtemperature.*

**Table 1. EN Configuration (JU1)**

SHUNT POSITION	DESCRIPTION
1-2*	Connects the EN pin to the voltage at SUP for normal operation.
2-3	Connects the EN pin to ground to enter shutdown mode.

\*Default position.

**Table 2. Mode of Operation (JU2)**

SHUNT POSITION	MODE PIN	MODE
1-2*	Connected to BIAS	Forced-PWM mode
2-3	Connected to AGND	Skip mode
Not installed	Connected to an external clock	Forced-PWM mode (device syncs to an external clock)

\*Default position.

[Ordering Information](#) appears at end of data sheet.

## Detailed Description of Hardware

The EV kit demonstrates the MAX17245 high-voltage, high-frequency, step-down converter with low operating current. The EV kit operates over a wide 6V to 36V input range and the output is set for 5V at 3.5A.

### Enable (EN)

Place a shunt in the 1-2 position on jumper JU1 for normal operation. To place the device into shutdown mode, move the shunt on JU1 to the 2-3 position.

### Synchronization Input (FSYNC)

The EV kit features jumper JU2 to control the synchronization input (FSYNC). Connect FSYNC to AGND to enable skip-mode operation. Connect to BIAS or to an external clock to enable fixed-frequency forced-PWM mode operation.

The device can be synchronized to an external signal applied to FSYNC. To use an external clock, uninstall the shunt on JU2 and apply the signal at the FSYNC test point. The external clock frequency at FSYNC can be higher or lower than the internal clock by 20%. Ensure that the duty cycle of the external clock used has a minimum 100ns pulse width.

### Synchronizing Output (SYNCOUT)

The EV kit provides a test point EXT\_5V to pull up the open-drain SYNCOUT to an external 5V supply. SYNCOUT is a 180° out-of-phase clock output relative to the internal oscillator at SYNCOUT to create cascaded power supplies with multiple MAX17245s.

### Setting the Switching Frequency (FOSC)

The EV kit switching frequency is set by a resistor,  $R_{FOSC}$  (R2), connected from  $F_{OSC}$  to AGND. Refer to *Figure 3* of the MAX17245 IC data sheet for a graphical approach of selecting the correct  $R_{FOSC}$  (R2) value.

### Power-Good Output (PGOOD)

The EV kit provides a PGOOD test point to monitor the status of the device output. PGOOD asserts when  $V_{OUT}$  rises above 95% of its regulation voltage. PGOOD deasserts when  $V_{OUT}$  drops below 92% of its regulation voltage.

### Output

Connect FB to BIAS for a fixed +5V (EV kit default output) output voltage. To set the output to other voltages between 1V and 10V, remove R12 and connect a resistive divider from output (OUT) to FB to AGND. Use the following formula to determine the R4 and R6 of the resistive-divider network:

$$R4 = R6 \times \left( \frac{V_{OUT}}{V_{FB}} - 1 \right)$$

where  $V_{FB} = 1V$ .

## Component Suppliers

SUPPLIER	WEBSITE
Murata Americas	www.murata.com
NXP Semiconductors	www.nxp.com
Panasonic Corp.	www.panasonic.com
Samsung Electro-mechanics	www.samsungsem.com
Taiyo Yuden	www.taiyo-yuden.com
Würth Elektronik GmbH & Co. KG	www.we-online.com

**Note:** Indicate that you are using the MAX17245 when contacting these component suppliers.

## Component Information, PCB Layout, and Schematics

See the following links for component information, PCB layout diagrams, and schematics.

- [MAX17245 EV BOM](#)
- [MAX17245 EV PCB Layout](#)
- [MAX17245 EV Schematic](#)
- [MAX17245 EV Minimal Component Schematic](#)

## Ordering Information

PART	TYPE
MAX17245EVKIT#	EV Kit

#Denotes RoHS compliant.

## Revision History

REVISION NUMBER	REVISION DATE	DESCRIPTION	PAGES CHANGED
0	3/16	Initial release	—

For pricing, delivery, and ordering information, please contact Maxim Direct at 1-888-629-4642, or visit Maxim Integrated's website at [www.maximintegrated.com](http://www.maximintegrated.com).

*Maxim Integrated cannot assume responsibility for use of any circuitry other than circuitry entirely embodied in a Maxim Integrated product. No circuit patent licenses are implied. Maxim Integrated reserves the right to change the circuitry and specifications without notice at any time.*

# MAX17245EVKIT#: Rev A

Item	Component Description	Qty	Reference Designators	Manufacturer	Part Number
0001	Testpoints, Black	5	AGND (3x), PGND (2x)	Keystone	5001
0002	Testpoints, Red	7	BIAS, EXT_SUP, EXT_5V, FSYNC, LX, /PGOOD, SYNCOUT	Keystone	5000
0003	47uF 20%, 50V aluminum electrolytic capacitor (8x10.2mm)	1	C1	Panasonic	EEE-TG1H470UP
0004	4.7uF 10%, 50V X7R ceramic capacitor (1206)	2	C2, C4	Taiyo Yuden	UMK316AB7475KL
0005	0.1uF 10%, 50V X7R ceramic capacitors (0603)	2	C3, C5	Murata	GCM188R71H104KA57D
0006	0.1uF 10%, 16V X7R ceramic capacitor (0402)	1	C6	Murata	GRM155R71C104K
0007	22uF 10%, 10V X7R ceramic capacitors (1206)	2	C7, C8	Samsung Electro	CL31B226KPHNNNE
0008	2.2uF 10%, 10V X7R ceramic capacitor (0603)	1	C10	Murata	GRM188R71A225K
0009	1000pF 10% 50V X7R ceramic capacitor (0402)	1	C12	Murata	GRM155R71H102K
0010	10pF 5% 50V C0G ceramic capacitor (0402)	1	C13	Murata	GRM1555C1H100J
0011	470pF 1% 50V C0G ceramic capacitor (0402)	1	C14	Murata	GCM1555C1H471FA16#J
0012	3A, 60V Schottky diode (SOD128)	1	D1	NXP	PMEG6030ETP
0013	JACKs, BANNANA, UNINSULATED, PANEL MOUNT	4	EXT_VBAT, OUT, PGND (2x)	JOHNSON	108-0740-001
0014	3 pin headers, 2.54mm, Comes in 36-40 Pin Strips (CUT TO FIT)	2	JU1, JU2	SULLINS	PEC36SAAN
0015	2.2uH, 13A inductor (7mm x 6.9mm)	1	L1	Würth Electronics	744311220
0016	20k ohms 1% resistor (0402)	1	R1	Any	Any
0017	16.5k ohms 1% resistor (0402)	1	R2	Any	Any
0018	10k ohms 5% resistor (0402)	1	R3	Any	Any
0019	1k ohms 5% resistor (0402)	1	R5	Any	Any
0020	2 ohms 1% resistor (0402)	1	R7	Any	Any
0021	0 ohms 5% resistor (1210)	1	R8	Any	Any
0022	0 ohms 5% resistors (0402)	3	R9, R10, R12	Any	Any
0023	100k ohms 5% resistor (0402)	1	R11	Any	Any
0024	Shunts	2	SU1, SU2	Kycon	SX1100-B
0025	Step-down Converter (16 TQFN-EP 5x5x0.8mm)	1	U1	Maxim	MAX17245ETESA+
0026	PC board: MAX17245 EV KIT	1	2 oz. Cu	CMR	MAX17245 EV KIT
0027	Not installed, ceramic capacitor (0402)	0	C15		
0028	Not installed, resistors (0402)	0	R4, R6		
0029	Not installed, resistors (0603)	0	R13		
0030	Maxim pads	0	EXT_VBAT, OUT, PGND (2x)		

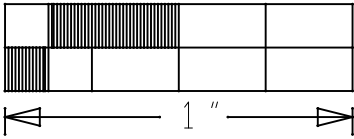
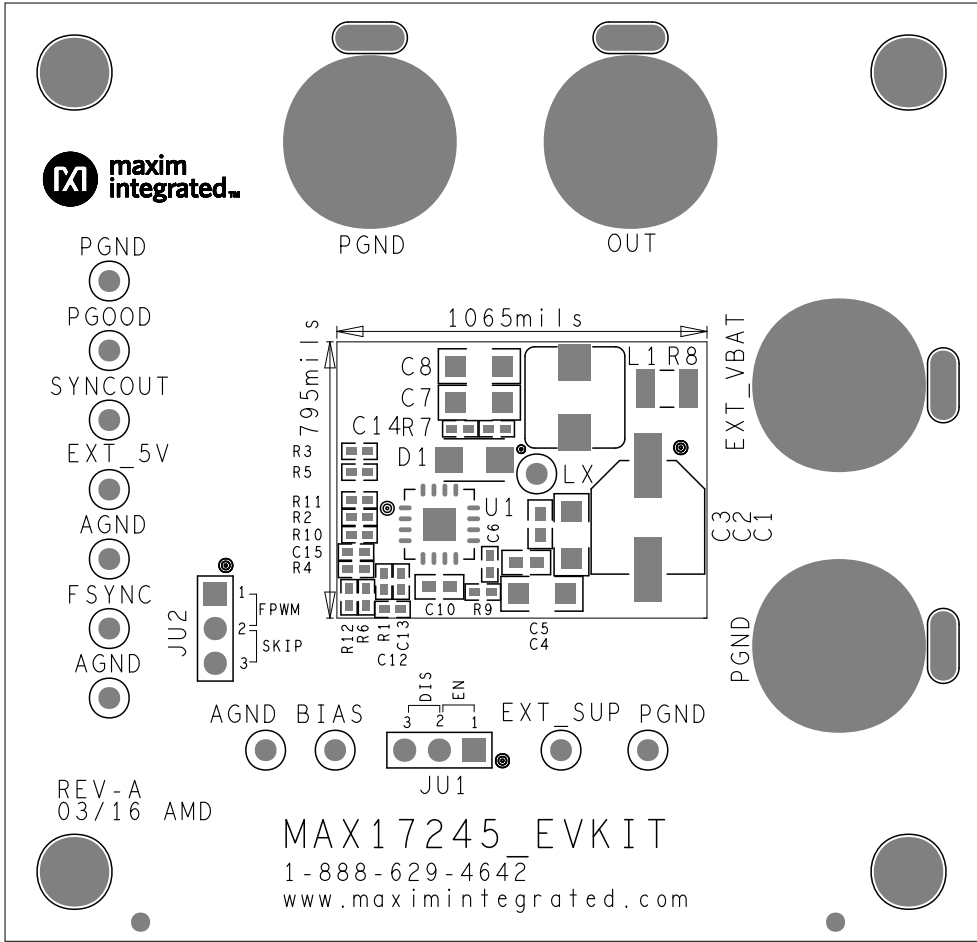

**Top Silkscreen**

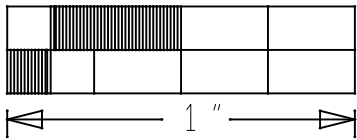
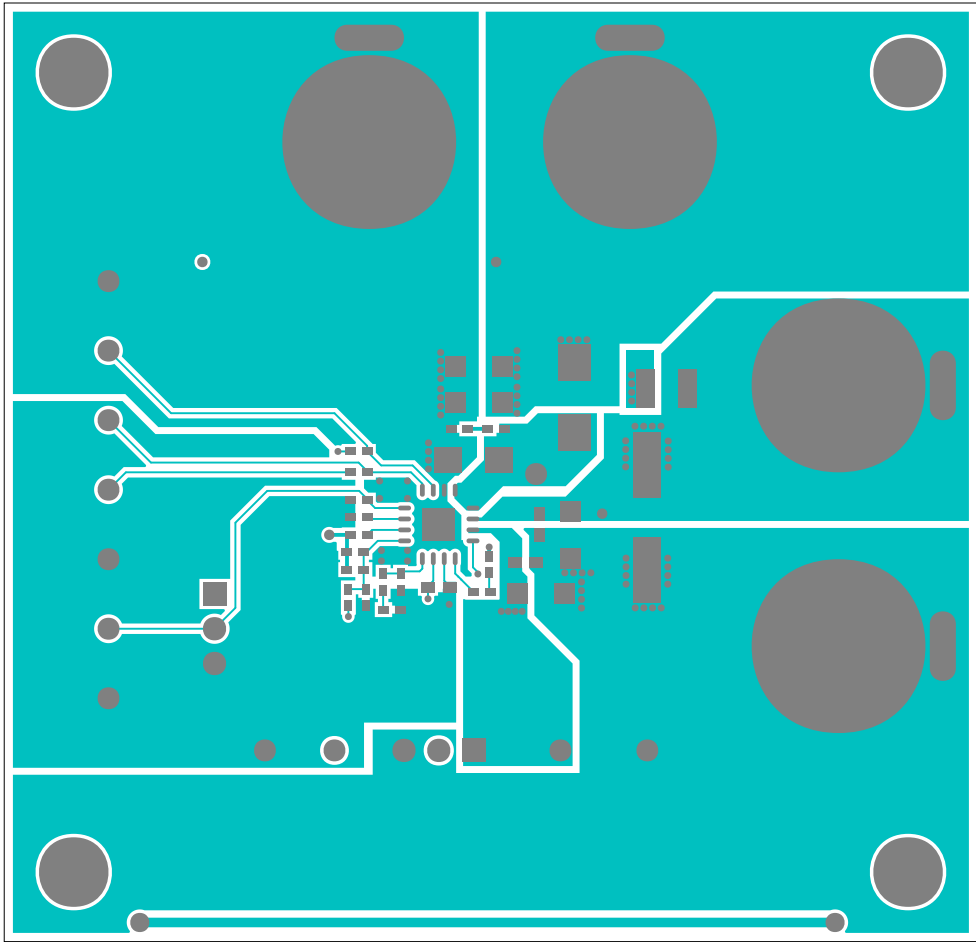

Top

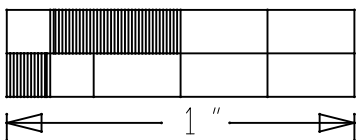
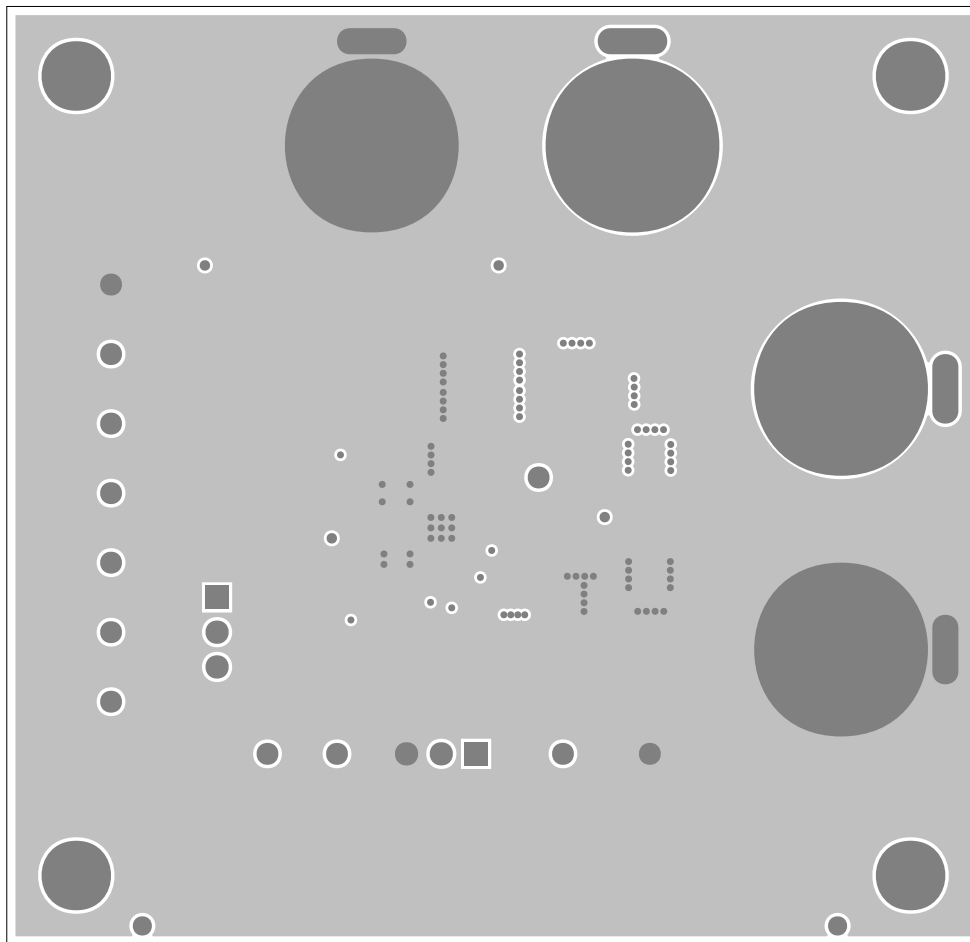

**Layer 2**



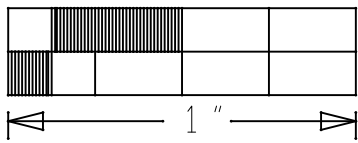
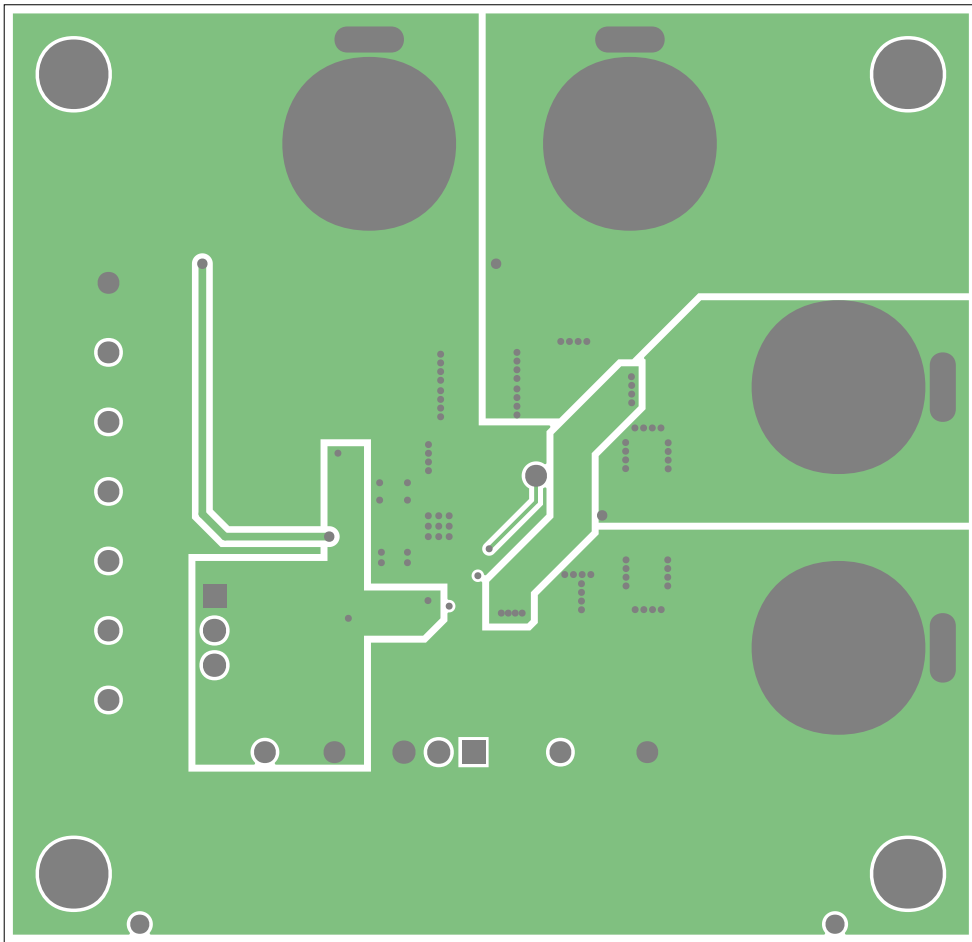

**Layer 3**

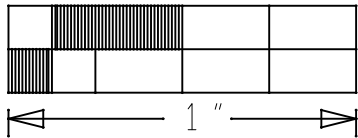
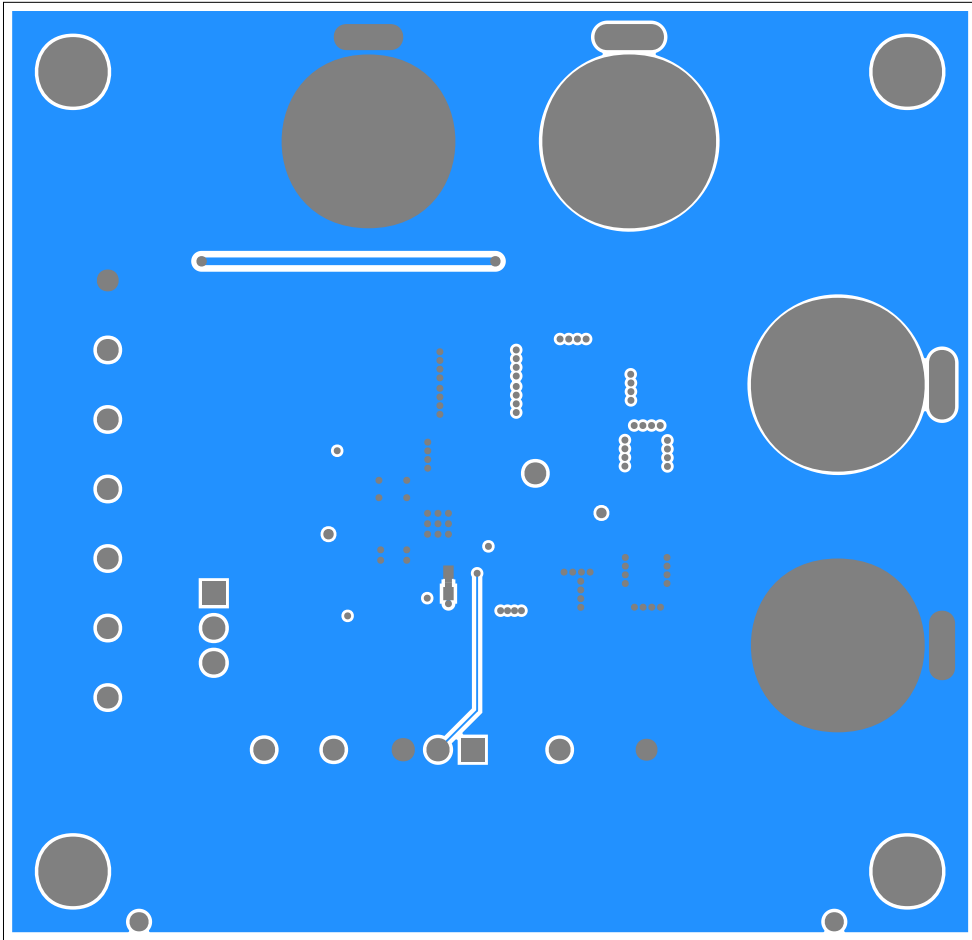

**Bottom**

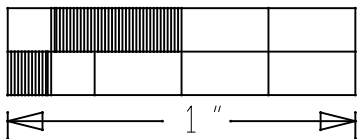
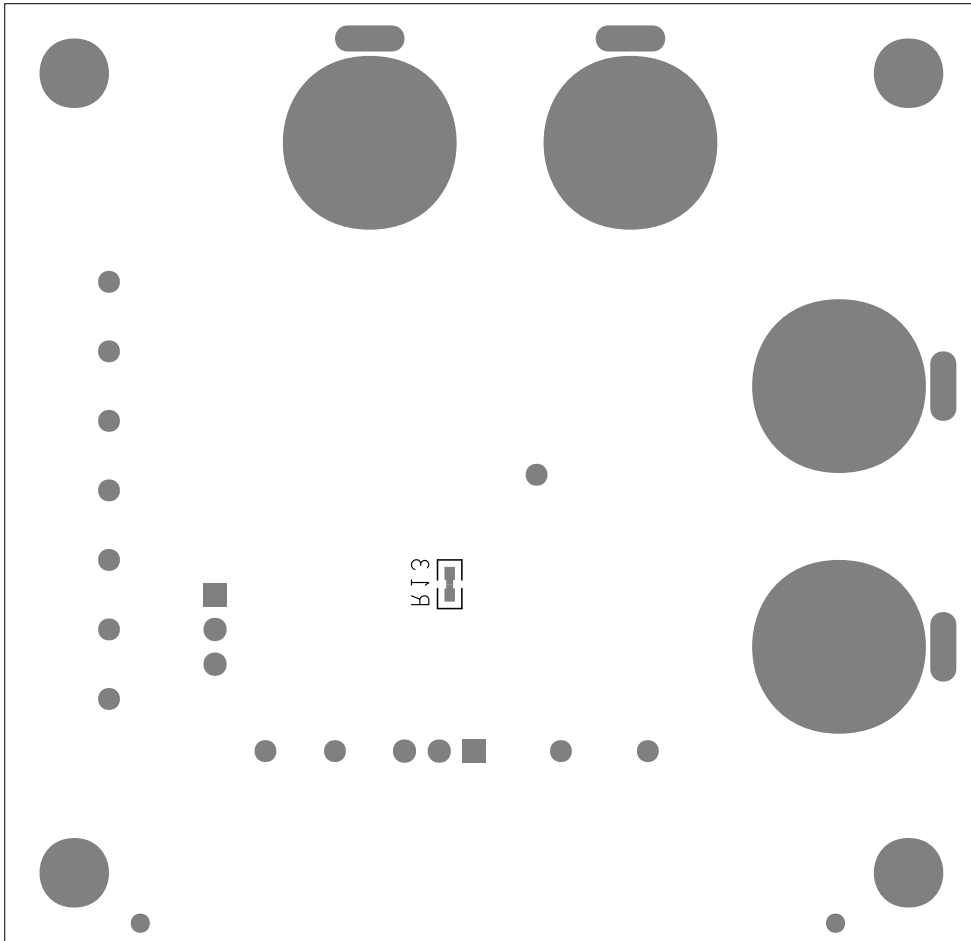

**Bottom Silkscreen**

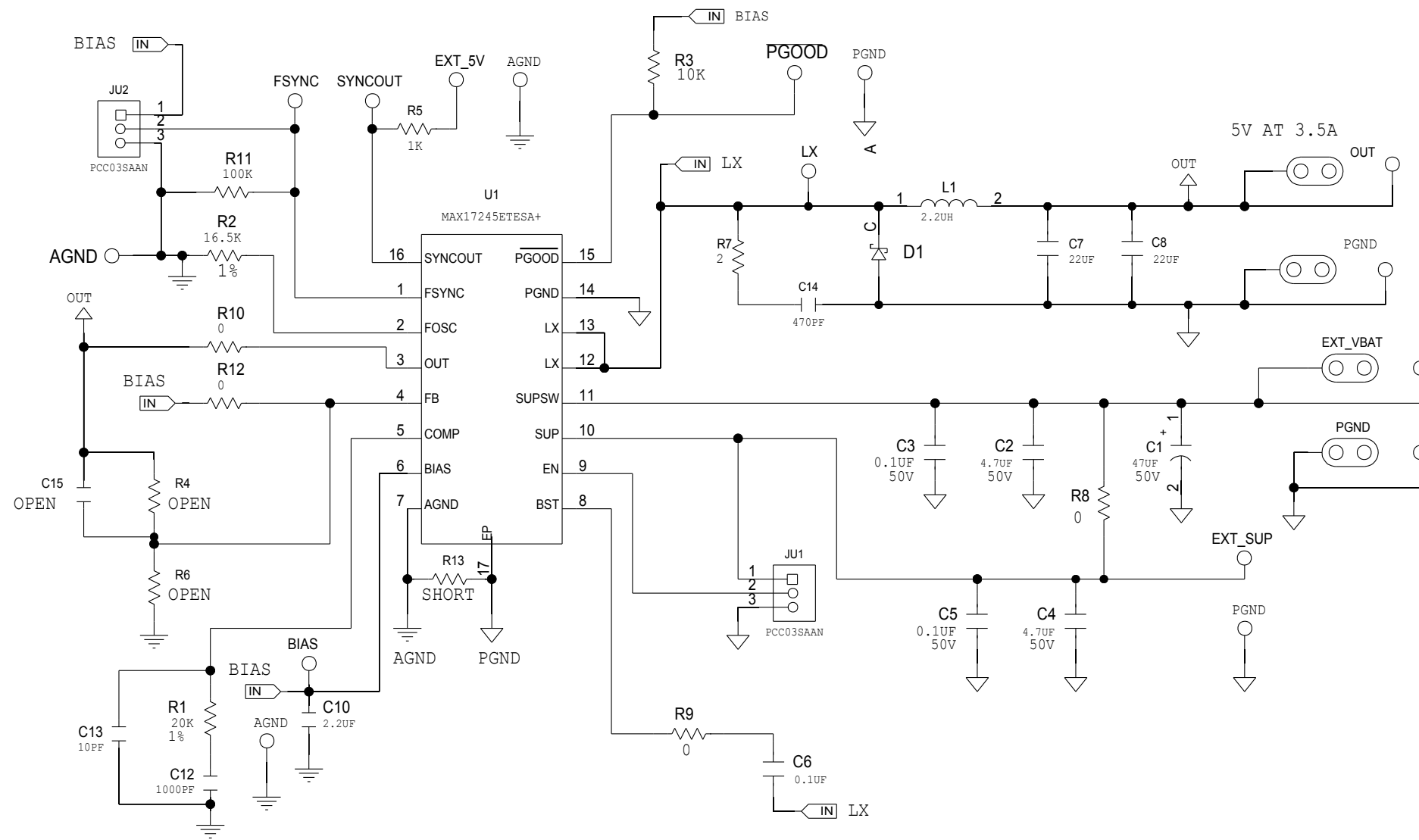

**Schematic**

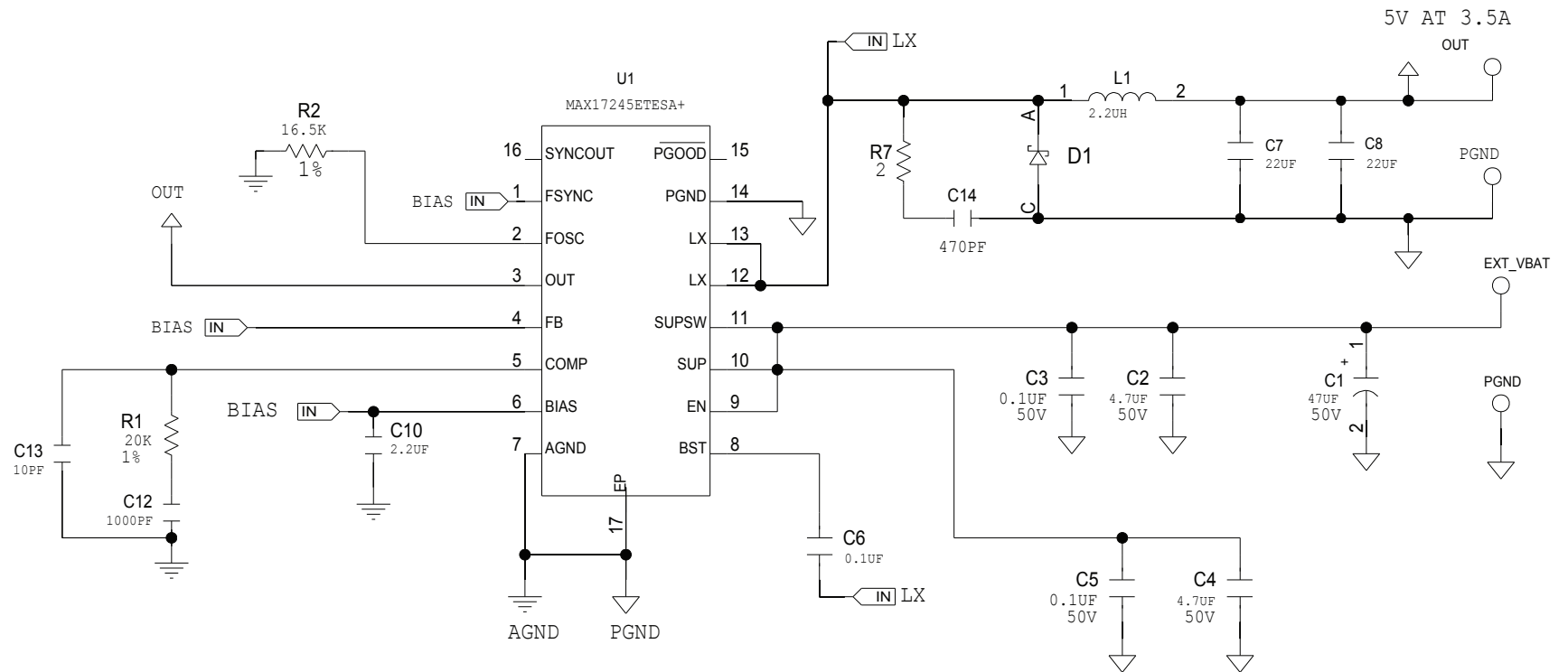

**Minimal Component Schematic**