

REL	WAS	DATE	D'MAN	APPD.
32508-157				
1 33780-57	ADD. NOTE II & DATA.	1-21-58	MOORE	
2 35826-4	RELOC & REV C DIM AND .000 +.016 -.047	8-30-59	BARTKOW	
A1 36200 -27	.188(16M), .250(12) & .500(4) (SOLDER WELL DEPTH); REM SOLDER WELL DATA FOR 16	2-11-60	MARKOWSKI	
A 36525 -325	REM PD COL (A & V THD) REV. NOTE 3, Q DIA COL, ADD NOTE 12	3-17-60	MARKOWSKI	
A3 36525 -448	ADDED NOTE 13, REV NOTE 12	7-5-60	PAWLICK	
A4 42525 -45	MIL-C-5015C (NOTE 1)	10-2-63	MILLAR	
A5 51175 -1	REM NOTE II, REVISION LETTER (C) (3 PLCS)	11-7-69	RANDALL	
A 53249 -14	ADD. 9-3895 (PRO SPEC) REV STAMPING NOTE	1-6-72	RANDALL	
B 76208 -1	(CL II) REV MS COL	4/30/85	BOWKER	

ACCESSORIES
(NOT PART OF STANDARD ASSEMBLY)

 GROMMET 10-40800 SERIES	 GROMMET RETAINING NUT SEE TABLE
 CABLE CLAMP 10-35900-XX3 SERIES	

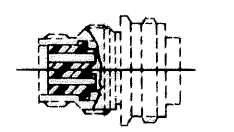
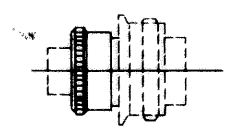
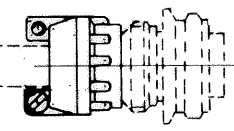
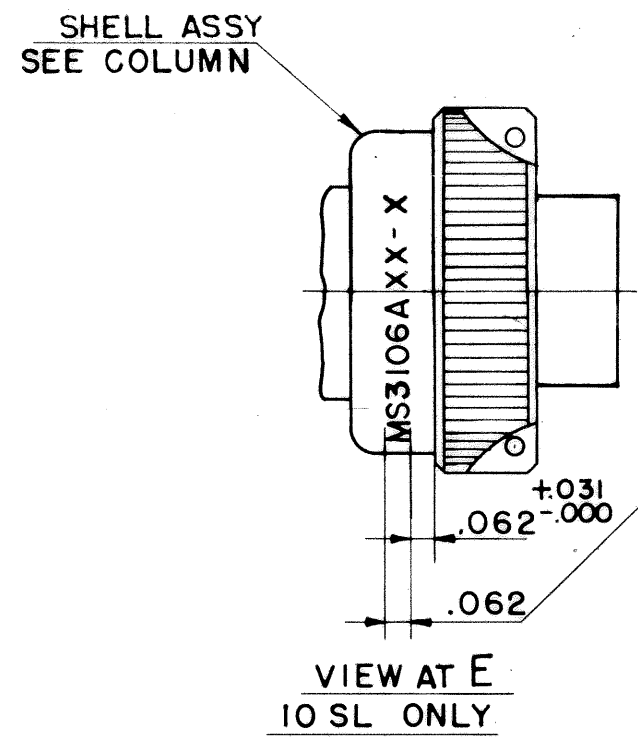

STAMP PER 9-2811
EXAMPLE:
MS3106A10SL-3S BENDIX-7139

NUT MUST TURN FREELY
AFTER STAMPING

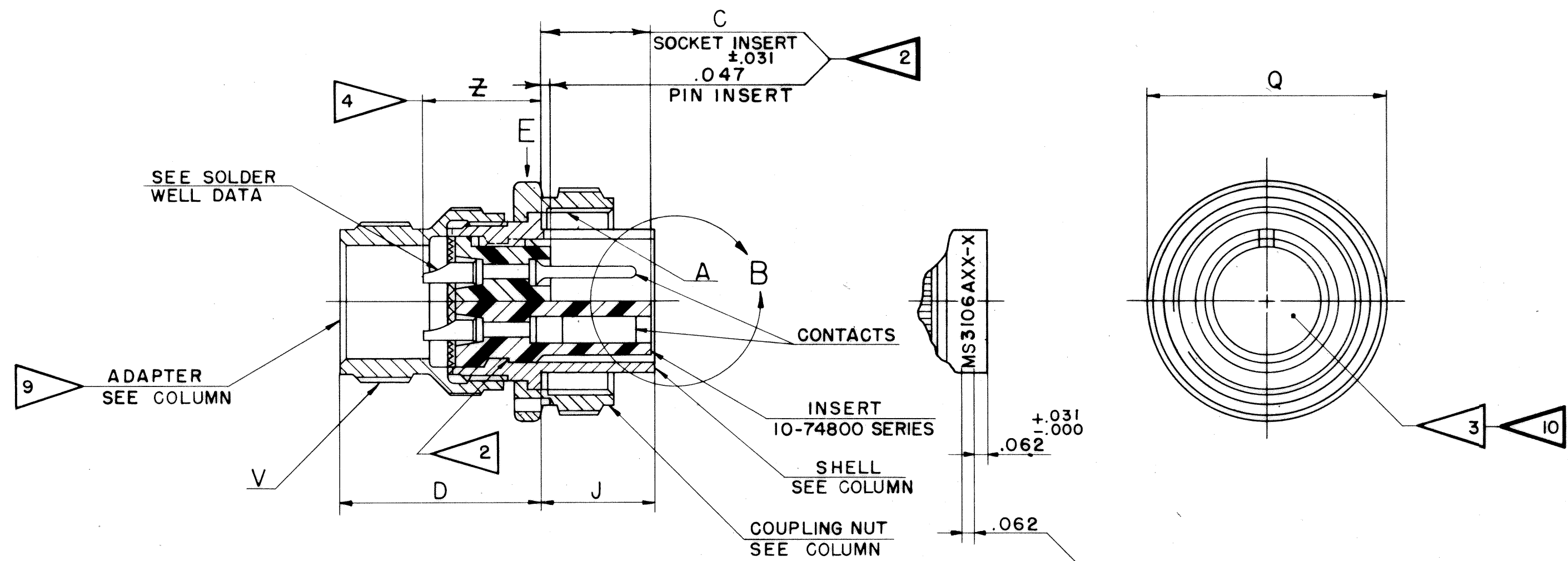

VIEW B
EXCEPT IOSL

STAMP PER 9-2811
MS NO., "BENDIX" & DATE CODE (9-3895)
OPPOSITE KEYWAY
EXAMPLE:
MS3106A20-12S BENDIX -7139

FOR SUFFIX OTHER THAN "P" OR "S",
STAMP PER 9-2437
(SUFFIX OF MS NO. ONLY)
EXAMPLE:
MS3106A20-12SX BENDIX -7139

10-168608 THRU
10-168640

USE OF THIS DOCUMENT IS UNLIMITED. DOCUMENTS REFERENCED HEREON CONTAIN LIMITED RIGHTS DATA.

CONTACT SIZE	0	4	8	12	16M
WELL DIA	.469 ^{+0.005} _{-.003}	.332 ^{+0.005} _{-.003}	.209 ^{+0.004} _{-.002}	.116 ^{+0.004} _{-.002}	.078 ^{+0.004} _{-.002}
WELL DEPTH ^{+0.031} _{-.000}	.625	.625	.500	.375	.250

MATERIAL SPEC.	PROCESS SPEC. SEE SHEET 2	SCINTILLA MAGNETO DIVISION BENDIX AVIATION CORPORATION SYDNEY, N. Y., U.S.A.				TOLERANCES UNLESS OTHERWISE SPECIFIED			
HEAT TREAT SPEC.	FINISH SPEC.	NAME CONNECTOR, ELECTRICAL PLUG, TYPE C () MC				FRACTIONS ± ~	ANGLES ± ~		
		D'MAN A S MEYER				DECIMALS ± .010	CONCENTRICITY FIR		
		CHECKER BRUNIC				SURFACE FINISHES MICRO-INCHES RMS VALUE MAX			
		MATERIAL MAT.				NEXT ASSEMBLY			
		STDS 4-24-57 9-57				WEIGHT-LBS SEE PARTS LIST			
		CH. D'MAN APPROVED 5-10-57				SUPERSEDES AND IS NOT INTERFERED BY			
		SCALE NONE				SUPERSEDED BY 10-168608 THRU 10-168640			
		TOOL ACC. COM. REC. 22563-8				DWG SIZE C TAR. CODE 77820 SHEET 1 OF 2			

SEE SHEET 2.
NOTES: REF SYMBOL

REL	32500-157	WAS	DATE	D'MAN	APPD.
1	33750-57	SEE SHEET I	1-21-58	MOORE	<i>[Signature]</i>
2	35826-4	SEE SHEET I	8-30-59	BARTKOW	<i>[Signature]</i>
A1	36200-27	SEE SHEET I	2-11-60	MAKOWSKI	<i>[Signature]</i>
A2	36525-325	SEE SHEET I	3-17-60	MAKOWSKI	<i>[Signature]</i>
A3	36525-448	SEE SHEET I	7-5-60	PAWLICK	<i>[Signature]</i>
A4	42525-45	SEE SHEET I	10-26-63	MALLAR	<i>[Signature]</i>

A5
A6
B
SEE SHEET I FOR ALL CHANGES

ASSEMBLY NO.	MS NO.	DIMENSIONS								DETAILS			ACCESSORY
		A THREAD CLASS 2B	G +.047 -.000	D	J ±.005	Q DIA MAX	V THREAD (PLATED) CLASS 2A	Z ±.045	SHELL	COUPLING NUT	ADAPTER	GROMMET RETAINING NUT	
10-168608 -	3106 A 8S -	.5000-28 UNEF	.531	.859 ±.030	.531	.741	.5000-28 UNEF	.562	10-37266 - 8	10-37265 - 8	10-37267 - 8	10-37269 - 8	
10-168610 -	10S -	.6250-24 NEF	.531	.937 ±.030	.531	.869	.5000-28 UNEF		10-37266-10	10-37265 -10	-10	-10	
10-168611 -	10SL -	.6250-24 NEF	.531	.937 ±.025	.531	.946	.6250-24 NEF		10-113488-11 (SHELL ASSY)		-12	-12	
10-168612 -	12S -	.7500-20 UNEF	.531	.937 ±.030	.531	.995			10-37266 - 12	10-37265 - 12	-12	-12	
10-168613 -	12 -	.7500-20 UNEF	.719	1.124 ±.030	.719	.995		.812	-13	-13	-13	-13	
10-168614 -	14S -	.8750-20 UNEF	.531	.937 ±.030	.531	1.123	.7500-20 UNEF	.562	-14	-14	-14	-14	
10-168615 -	14 -	.8750-20 UNEF	.719	1.124 ±.030	.719	1.123	.7500-20 UNEF	.812	-15	-15	-15	-15	
10-168616 -	16S -	1.0000-20 UNEF	.531	.937 ±.030	.531	1.250	.8750-20 UNEF	.562	-16	-16	-16	-16	
10-168617 -	16 -	1.0000-20 UNEF	.719	1.124 ±.030	.719	1.250	.8750-20 UNEF	.812	-17	-17	-17	-17	
10-168618 -	18 -	1.1250-18 NEF		1.219 ±.030		1.333	1.0000-20 UNEF		-18	-18	-18	-18	
10-168620 -	20 -	1.2500-18 NEF		1.125 ±.030		1.461	1.1875-18 NEF		-20	-20	-20	-20	
10-168622 -	22 -	1.3750-18 NEF		1.219 ±.030		1.588	1.1875-18 NEF		-22	-22	-22	-22	
10-168624 -	24 -	1.5000-18 NEF		1.251 ±.030		1.715	1.4375-18 NEF		-24	-24	-24	-24	
10-168628 -	28 -	1.7500-18 NS		1.470 ±.030		1.968	1.4375-18 NEF		-28	-28	-28	-28	
10-168632 -	32 -	2.0000-18 NS		1.439 ±.030		2.209	1.7500-18 NS		-32	-32	-32	-32	
10-168636 -	36 -	2.2500-16 UN		1.500 ±.030		2.463	2.0000-18 NS		-36	-36	-36	-36	
10-168640 -	40 -	2.5000-16 UN		1.469 ±.030		2.718	2.2500-16 UN		-40	-40	-40	-40	

10-168608 THRU
10-168640



- 1. THE UNITS ILLUSTRATED MEET THE REQUIREME OF MS3016A, PER SPEC MIL-C-5015(D).
- 2. DIMENSIONS MUST BE MAINTAINED WHEN INSERTS ARE PRESSED FIRMLY AGAINST INDICATED SHOULDER.
- 3. FOR CONTACT SIZE, SPACING, & SERVICE RATING, SEE DRAWINGS MS33680 THRU MS33690.
- 4. INCREASE Z DIMENSION BY .312 FOR SIZE "O" CONTACT ONLY.
- 5. TO COMPLETE ASSEMBLY NUMBER & MS NUMBER, ADD APPLICABLE INSERT ARRANGEMENT SUFFIX TO BASE NUMBERS LISTED ABOVE. (FOR ALTERNATE ARRANGEMENTS, REFER TO 9-2437.) TO DETERMINE DESIRED INSERT ARRANGEMENT, SEE PARTS LISTS 10-168608 THRU 10-168640.
- 6. SEE WORK ORDER FOR PERMISSIBLE ADDITIONAL OR ALTERNATE STAMPING.
- 7. SEE DRAWINGS 10-168008 THRU 10-168040 10-168208 THRU 10-168240 FOR REQUIRED MATING RECEPTACLE ASSEMBLIES.
- 8. ALL LOCKWIRE HOLES ARE .045 DIA MIN.
- 9. ADAPTER MUST BE REMOVED WHEN GROMMET RETAINING NUT IS USED.
- 10. INSERTS AND CONTACTS ARE REMOVABLE.
- 11.
- 12. FOR PART NUMBERS 10-168617-13, 10-168618-15, & 61 - SEE INDIVIDUAL DRAWINGS 10-168617-13, 10-168618-15, & 61-00000.
- 13. FOR DIMENSIONS AND STAMPING ON ALL ARRANGEMENTS WITH SUFFIX -50 OR ABOVE SEE INDIVIDUAL DRAWING OF SAME SHELL SIZE & SUFFIX IN 10-41600 SERIES.

MATERIAL SPEC.	PROCESS SPEC. TEST 9-3106-5	SCINTILLA MAGNETO DIVISION BENDIX AVIATION CORPORATION SIDNEY, N. Y., U.S.A.				TOLERANCES UNLESS OTHERWISE SPECIFIED	
HEAT TREAT SPEC.	ASSY 9-3103-1	NAME CONNECTOR ELECTRICAL PLUG, TYPE C()MC				FRACTIONS ±	ANGLES
TOOL ACC.	9-2811, 9-2437 9-3895	D'MAN CHECKER MAT. ST'DS CH. D'MAN APPROVED SCALE				DECIMALS ± .010	CONCENTRICITY
	CON. REC. 21649-4 4-25-57 59.57	ASMEY BALANTIC				SURFACE ROUGHNESS MICRO-INCHES RMS VALUE MAX	
		NONE				NEXT ASSEMBLY	
		SUPERSEDES				AND IS NOT INTERCHANGEABLE	
		SUPERSEDED BY				10-168608 THRU 10-168640	
		DWG SIZE C				SHEET 2 OF 2	