

SCHNITT A-A

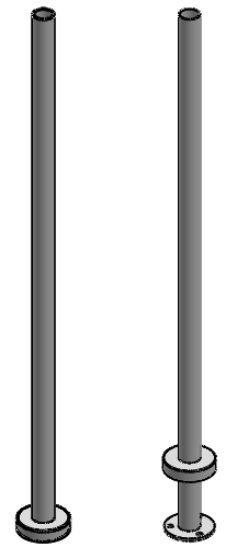

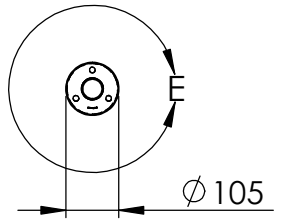

SCHNITT B-B

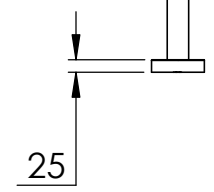
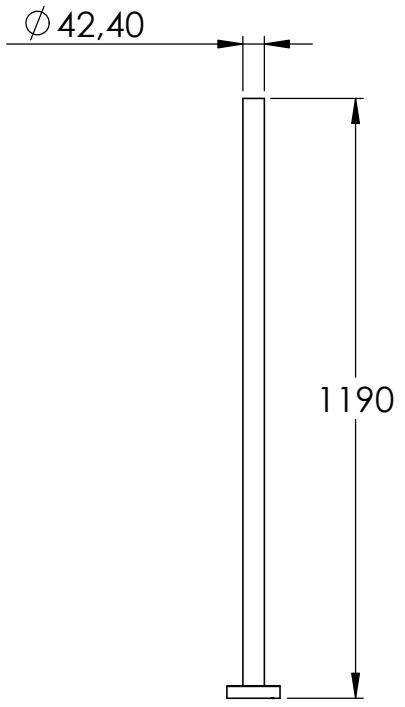
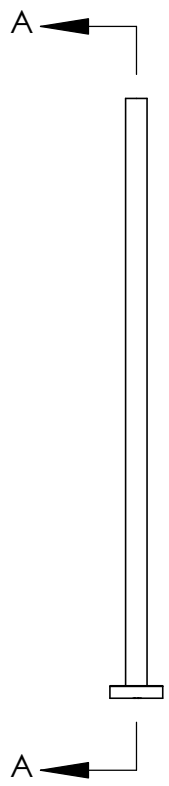
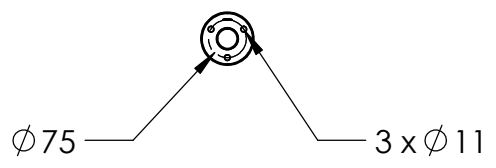
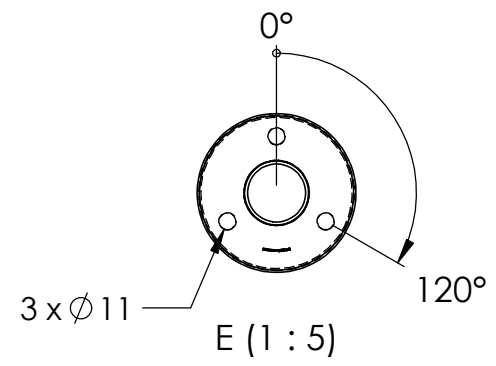
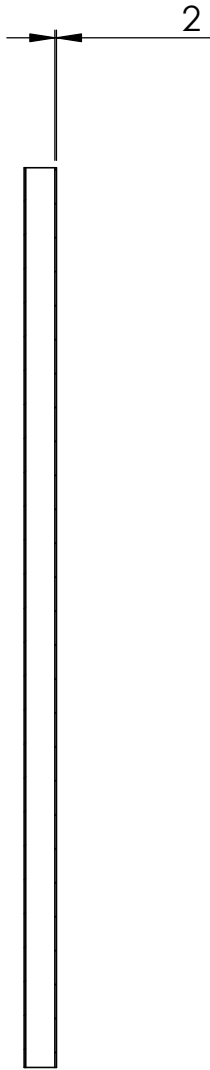
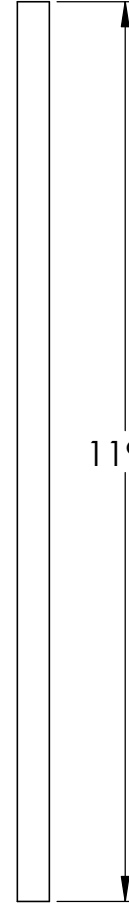
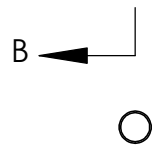
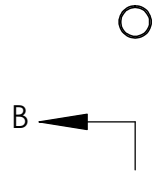

1190

