

MVB.L Vertical toggle clamps, long life series

with straight base, steel



MATERIAL

Black-oxide steel.

ROTATING PINS

Hardened, black-oxide and ground steel.

SUPPORT BUSHING

Hardened, black-oxide and ground steel.

ADJUSTING SCREW AND NUT

Zinc-plated steel.

HANDLE

Polyurethane, red colour.

STANDARD EXECUTIONS

- **MVB.LLB**: with open clamping lever and two folded washers.
- **MVB.LLF**: with solid clamping lever.

CLAMPING BOLTS

To be ordered separately.

FEATURES AND APPLICATIONS

All articulated joints are lubricated with special grease. During clamping, the lever is controlled to prevent impact on functioning due to side thrust.

High-quality materials make Long Life series toggle clamps suitable for medium to heavy loads on welding jigs, carpentry works, moulds and in general whenever high clamping torque and repetitive movements are required.

Certified for 1.000.000 cycles.

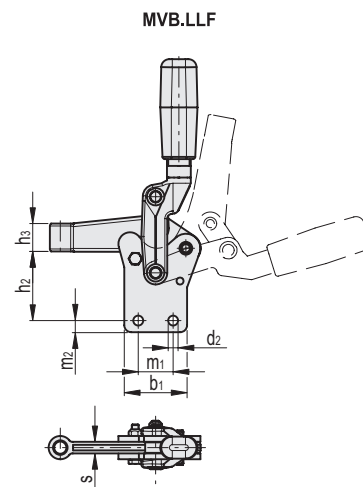
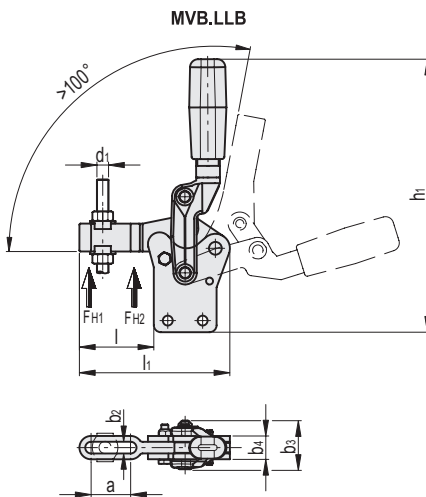
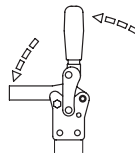

MVB.LLB

Code	Description	a	b1	b2	b3	b4	d1	d2	h1	h2	h3	l	l1	l2	m1	m2	FH1 [N]*	FH2 [N]*	⚖️
GG.AA605	MVB.LLB01	32	36	6	29	13	M6	6.5	152	37.5	16	49	91	51	20	8	2200	2800	330
GG.AA635	MVB.LLB02	34	54	10	42.5	20	M10	8.5	235	59.5	24	64	129.5	66	30	10	4400	8200	1200

MVB.LLF

Code	Description	b1	b3	b4	d1	d2	h1	h2	h3	l	l1	m1	m2	s	FH1 [N]*	FH2 [N]*	⚖️
GG.AA615	MVB.LLF01	36	29	13	M6	6.5	152	37.5	16	44	86	20	8	6	2200	2800	325
GG.AA645	MVB.LLF02	54	42.5	20	M10	8.5	235	59.5	24	64	129.5	30	10	10	4400	8200	1200
GG.AA665	MVB.LLF03	75	52	24	M12	10.5	301	78	30	74	161	55	10	12	8500	-	2200
GG.AA685	MVB.LLF04	90	68	32	M16	12.5	360	88.5	35	96	203	65	12	16	15400	-	4470

* Holding force.



Models all rights reserved in accordance with the law. Always mention the source when reproducing our drawings and photos.

11/2019

