

# Check valve, pilot operated

**RE 21543/07.05**  
Replaces: 02.03

1/4

## Type Z2SRK

Size 6  
Component series 1X  
Maximum operating pressure 210 bar  
Maximum flow 40 l/min



## Table of contents

Contents	Page
Features	1
Ordering code	2
Function, section, circuit example, symbol	2
Technical data	3
Characteristic curves	3
Unit dimensions	4

## Features

- Sandwich plate valve
- Position of ports to ISO 4401-03-02-0-94
- For the leak-free isolation of two actuator ports

Information on available spare parts:  
[www.boschrexroth.com/spc](http://www.boschrexroth.com/spc)

### Ordering code

Z2SRK 6 - 1 - 1X / V \*

Check valve, sandwich plate

Size 6	= 6
Cracking pressure 1.5 bar	= 1
Component series 10 to 19 (10 to 19: unchanged installation and connection dimensions)	= 1X

Further details in clear text	
/60 <sup>1)</sup> =	With locating bore
/62 =	With locating bore and locating pin ISO 8752-3x8-St
V =	FKM seals <b>⚠ Caution!</b> Observe compatibility of seals with hydraulic fluid used!

<sup>1)</sup> Locating pin ISO 8752-3x8-St,  
Material no. R900005694 (separate order)

### Function, section, circuit example, symbol ( ① = component side, ② = plate side)

Isolator valve type Z2SRK 6 is a pilot operated check valve of sandwich plate design.

It is used for the leak-free closure of two actuator ports, even during longer periods of standstill.

The oil can freely flow from A1 to A2 or B1 to B2, whereas in the opposite direction the flow is blocked.

When fluid flows through the valve from A1 to A2 or B1 to B2,

spool (1) is pressurised, shifted to the right or to the left and causes poppet (2) to be pushed off its seat. Hydraulic fluid can now flow from B2 to B1 or from A2 to A1.

To allow reliable closing of poppets (2), the actuator ports of the directional valve must be unloaded to tank in the central position (see circuit example).

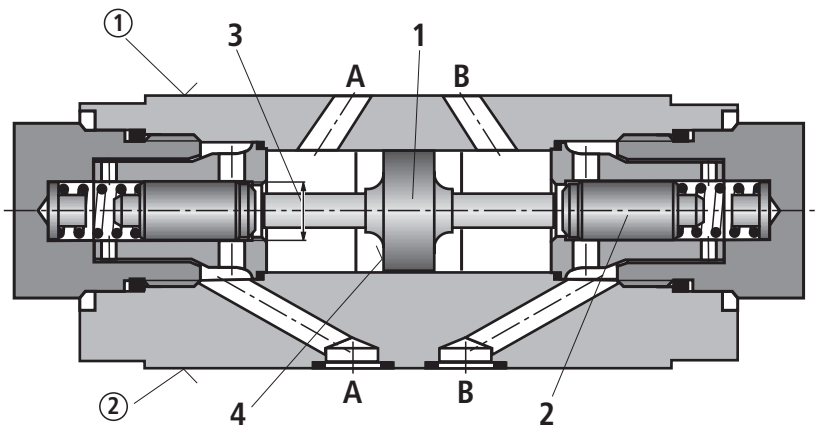
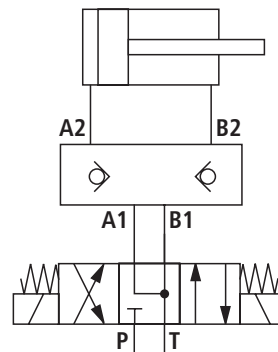
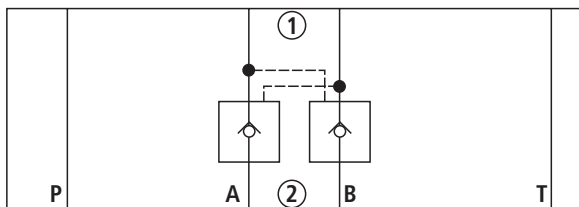

3 Area A<sub>1</sub>  
4 Area A<sub>2</sub>

**Technical data** (for applications outside these parameters, please consult us!)

<b>General</b>		
Weight	kg	approx. 0.5
Installation orientation		Optional
Ambient temperature range	°C	-20 to +80
<b>Hydraulic</b>		
Maximum operating pressure	bar	210
Cracking pressure in free direction	bar	See characteristic curves below
Maximum flow	l/min	40
Direction of flow		See Symbol on page 2
Hydraulic fluid		Mineral oil (HL, HLP) to DIN 51524; fast bio-degradable hydraulic fluids to VDMA 24568 (see also RE 90221); HETG (rape seed oil); HEPG (polyglycols); HEES (synthetic esters); other hydraulic fluids on enquiry
Hydraulic fluid temperature range	°C	-20 to +80
Viscosity range	mm <sup>2</sup> /s	2.8 to 500
Max. permissible degree of contamination of the hydraulic fluid - cleanliness class nach ISO 4406 (c)		Class 20/18/15 <sup>1)</sup>
Area ratio		$A_1/A_2 = 1/3$ (see sectional drawing on page 2)

<sup>1)</sup> The cleanliness classes specified for components must be adhered to in hydraulic systems. Effective filtration prevents malfunction and, at the same time, prolongs the service life of components.

For the selection of filters, see data sheets RE 50070, RE 50076, RE 50081, RE 50086 and RE 50088.

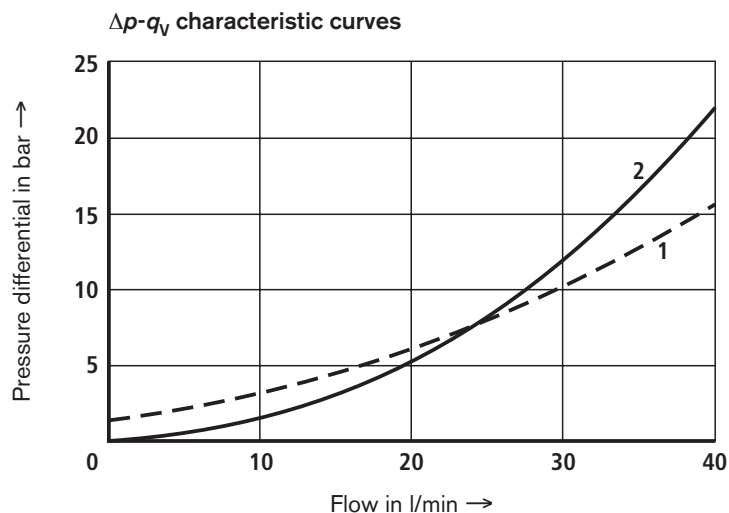
**Characteristic curves** (measured with HLP46,  $\vartheta_{oil} = 40 \text{ °C} \pm 5 \text{ °C}$ )

- 1 Cracking pressure 1.5 bar (from ① to ②)
- 2 Across check valve insert (opened from ② to ①)

## Unit dimensions (nominal dimensions in mm)

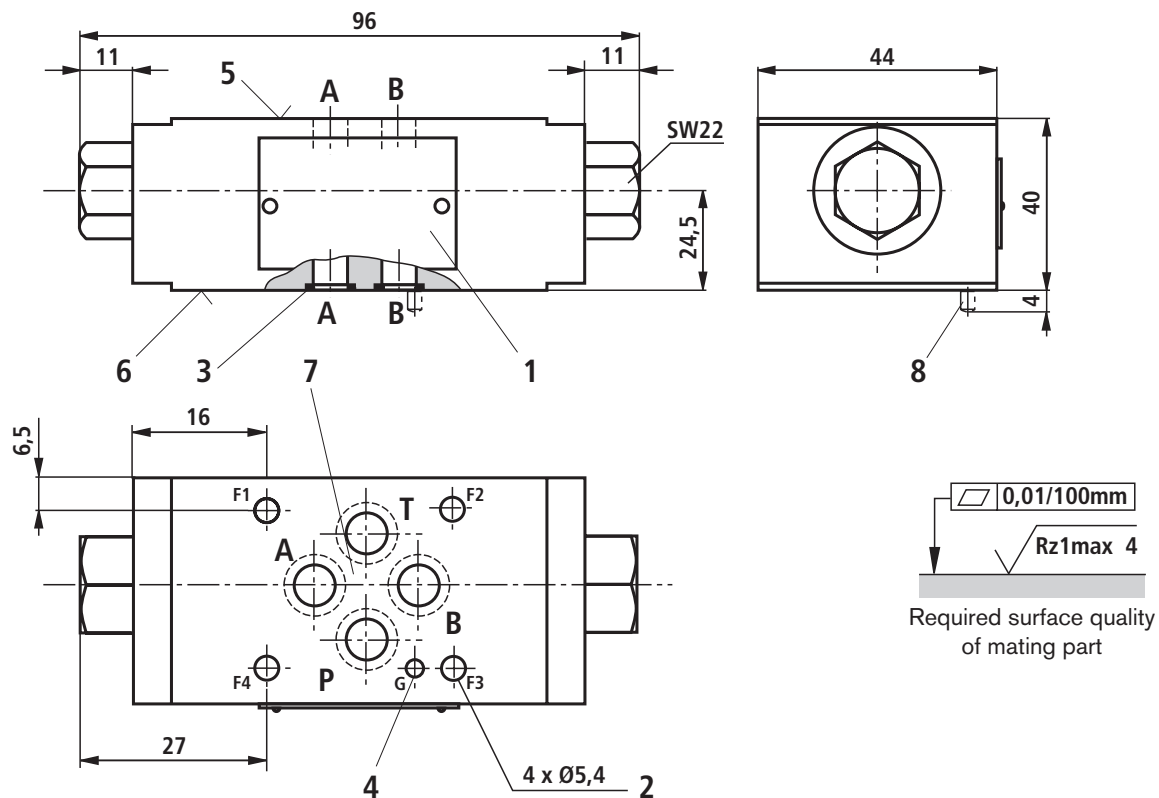

- 1 Nameplate
- 2 Valve fixing bores
- 3 Identical seal rings for ports A, B, P, T
- 4 Bore  $\varnothing 3$  for locating pin ISO 8752-3x8-St, material no. **R900005694** (separate order)
- 5 Component side
- 6 Plate side
- 7 Position of ports to ISO 4401-03-02-0-94
- 8 Locating pin ISO 8752-3x8-St; version "/62" only

**Valve fixing screws** (separate order)

**4 socket head cap screws ISO 4762 - M5 - 10.9**

(friction coefficient  $\mu_{\text{total}} = 0.14$ );

tightening torque  $M_T = 8.9 \text{ Nm} \pm 10\%$

(please adapt in the case of changed surfaces)