

# PN2594

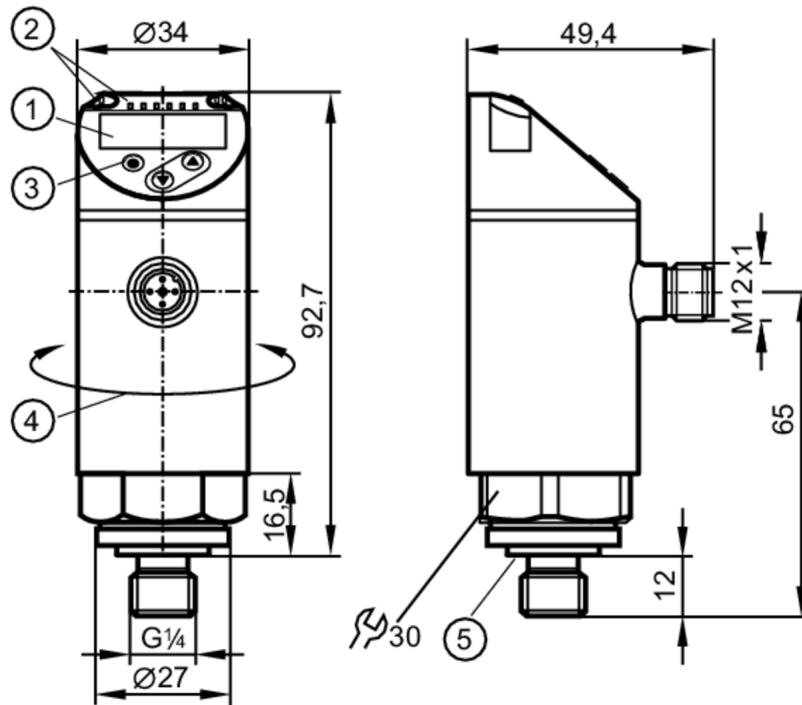

## Pressure sensor with display

PN-010-REG14-MFRKG/US/ IV



- 1 alphanumeric display 4-digit red/green
- 2 LEDs Display unit / switching status
- 3 programming button
- 4 upper part of the housing can be rotated 345°
- 5 Sealing



### Product characteristics

Output signal	switching signal; analogue signal; IO-Link; (configurable)			
Measuring range	-1...10 bar	-14.6...145 psi	-100...1000 kPa	-0.1...1 MPa
Process connection	threaded connection G 1/4 external thread (DIN EN ISO 1179-2); internal thread M5			

### Application

Special feature	Gold-plated contacts		
Measuring element	ceramic-capacitive pressure measuring cell		
Application	for industrial applications		
Media	liquids and gases		
Medium temperature [°C]	-25...80		
Pressure rating	75 bar	1087 psi	7.5 MPa
Min. bursting pressure	150 bar	2175 psi	15 MPa
Vacuum resistance [mbar]	-1000		
Type of pressure	relative pressure; vacuum		

# PN2594



## Pressure sensor with display

PN-010-REG14-MFRKG/US/ IV

Electrical data					
Operating voltage	[V]	18...30 DC; (according to EN 50178 SELV/PELV)			
Current consumption	[mA]	< 35			
Min. insulation resistance	[MΩ]	100; (500 V DC)			
Protection class		III			
Reverse polarity protection		yes			
Power-on delay time	[s]	0.3			
Integrated watchdog		yes			
Inputs / outputs					
Number of inputs and outputs		Number of digital outputs: 2; Number of analogue outputs: 1			
Outputs					
Total number of outputs		2			
Output signal		switching signal; analogue signal; IO-Link; (configurable)			
Electrical design		PNP/NPN			
Number of digital outputs		2			
Output function		normally open / normally closed; (parameterisable)			
Max. voltage drop switching output DC	[V]	2			
Permanent current rating of switching output DC	[mA]	250			
Switching frequency DC	[Hz]	< 500			
Number of analogue outputs		1			
Analogue current output	[mA]	4...20; (scalable 1:5)			
Max. load	[Ω]	500			
Analogue voltage output	[V]	0...10; (scalable 1:5)			
Min. load resistance	[Ω]	2000			
Short-circuit protection		yes			
Type of short-circuit protection		pulsed			
Overload protection		yes			
Measuring/setting range					
Measuring range		-1...10 bar	-14.6...145 psi	-100...1000 kPa	-0.1...1 MPa
Set point SP		-0.94...10 bar	-13.6...145 psi		-0.094...1 MPa
Reset point rP		-0.98...9.96 bar	-14.2...144.4 psi		-0.098...0.996 MPa
Analogue start point		-1...8 bar	-14.6...116 psi		-0.1...0.8 MPa
Analogue end point		1...10 bar	14.6...145 psi		0.1...1 MPa
In steps of		0.02 bar	0.2 psi		0.002 MPa
Accuracy / deviations					
Switch point accuracy	[% of the span]	< ± 0,4; (Turn down 1:1)			
Repeatability	[% of the span]	< ± 0,1; (with temperature fluctuations < 10 K; Turn down 1:1)			
Characteristics deviation	[% of the span]	< ± 0,25 (BFSL) / < ± 0,5 (LS); (Turn down 1:1; BFSL = Best Fit Straight Line; LS = limit value setting)			
Hysteresis deviation	[% of the span]	< ± 0,1; (Turn down 1:1)			
Long-term stability		< ± 0,05; (Turn down 1:1; per 6 months)			

# PN2594



## Pressure sensor with display

PN-010-REG14-MFRKG/US/ IV

	[% of the span]	
Temperature coefficient zero point	[% of the span / 10 K]	$< \pm 0,2; (-0...80 \text{ } ^\circ\text{C})$
Temperature coefficient span	[% of the span / 10 K]	$< \pm 0,2; (-0...80 \text{ } ^\circ\text{C})$

Response times		
Response time	[ms]	$< 1.5$
Delay time programmable dS, dr	[s]	0...50
Damping for the switching output dAP	[s]	0...4
Damping for the analogue output dAA	[s]	0...4
Max. response time analogue output	[ms]	3

Software / programming	
Parameter setting options	hysteresis / window; normally open / normally closed; switch-on/ switch-off delay; Damping; Display unit; current/voltage output

Interfaces	
Communication interface	IO-Link
Transmission type	COM2
IO-Link revision	1.1
SDCI standard	IEC 61131-9
IO-Link device ID	463 d / 00 01 cf h
Profiles	Smart Sensor: Process Data Variable; Device Identification, Device Diagnosis
SIO mode	yes
Required master port type	A
Process data analogue	1
Process data binary	2
Min. process cycle time	[ms] 2.3

Operating conditions		
Ambient temperature	[°C]	-25...80
Storage temperature	[°C]	-40...100
Protection		IP 65; IP 67

Tests / approvals		
EMC	DIN EN 61000-6-2	
	DIN EN 61000-6-3	
Shock resistance	DIN EN 60068-2-27	50 g (11 ms)
Vibration resistance	DIN EN 60068-2-6	20 g (10...2000 Hz)
MTTF	[years]	138
UL approval	UL Approval no.	J012
Pressure Equipment Directive	Sound engineering practice; can be used for group 2 fluids; group 1 fluids on request	

# PN2594



## Pressure sensor with display

PN-010-REG14-MFRKG/US/ IV

Mechanical data	
Weight [g]	262
Materials	stainless steel (1.4404 / 316L); PBT+PC-GF30; PBT-GF20; PC
Materials (wetted parts)	stainless steel (1.4404 / 316L); Al2O3 (ceramics); FKM
Min. pressure cycles	100 million
Tightening torque [Nm]	25...35; (recommended tightening torque; depends on lubrication, seal and pressure rating)
Process connection	threaded connection G 1/4 external thread (DIN EN ISO 1179-2); internal thread M5
Process connection sealing	FKM (to DIN 3869)
Restrictor element integrated	no (can be retrofitted)

Displays / operating elements		
Display	Display unit	3 x LED, green (bar, psi, MPa)
	switching status	2 x LED, yellow
	measured values	alphanumeric display, red/green 4-digit

Remarks	
Pack quantity	1 pcs.

### Electrical connection

Connector: 1 x M12; Contacts: gold-plated



# PN2594



## Pressure sensor with display

PN-010-REG14-MFRKG/US/ IV

### Connection

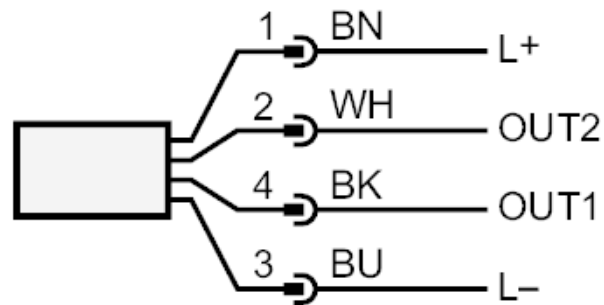

OUT1            switching output

OUT2            switching output

analogue output

Core colours :

BK =            black

BN =            brown

BU =            blue

WH =            white