



UT232E

CMOS IC

HIGH PERFORMANCE RS-232 LINE DRIVERS/RECEIVERS

DESCRIPTION

The UTC **UT232E** has two drivers and two receivers with dual charge-pump circuit. It meets RS-232D and V.28 specifications. Its high performance includes increased drive current for longer and more flexible cable configurations and 10V/μs slew rate, 120kbps guaranteed transmission rate. For easier use, enhancements include better ESD protection for RS-232 I/O pins, low power dissipation and four external small 0.1μF charge pump capacitors.

FEATURES

- * Single power supply: 3.3V~5.5V
- * Low power supply current: 3.0mA
- * Multiple drivers and receivers
- * Receiver input levels: ±25V
- * 3-State outputs of TTL/CMOS receiver
- * High output slew rate: 10V/μs under load
- * High data rate: 120kbps under load
- * Four external small charge pump capacitors: 0.1μF
- * Exceeds ±8KV HBM ESD protection for RS-232 I/O pins

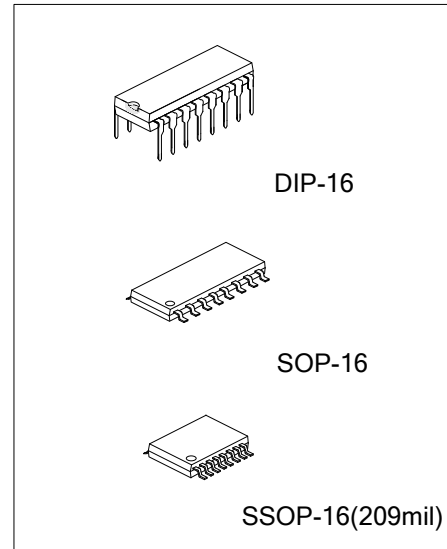

ORDERING INFORMATION

Ordering Number		Package	Packing
Lead Free	Halogen Free		
UT232EL-D16-T	UT232EG-D16-T	DIP-16	Tube
UT232EL-S16-R	UT232EG-S16-R	SOP-16	Tape Reel
UT232EL-R16-R	UT232EG-R16-R	SSOP-16	Tape Reel

<p>UT232EG-D16-T</p>	<p>(1) T: Tube, R: Tape Reel</p> <p>(2) D16: DIP-16, S16: SOP-16, R16: SSOP-16</p> <p>(3) G: Halogen Free and Lead Free, L: Lead Free</p>
----------------------	---

MARKING

DIP-16	SOP-16 / SSOP-16

■ PIN CONFIGURATION

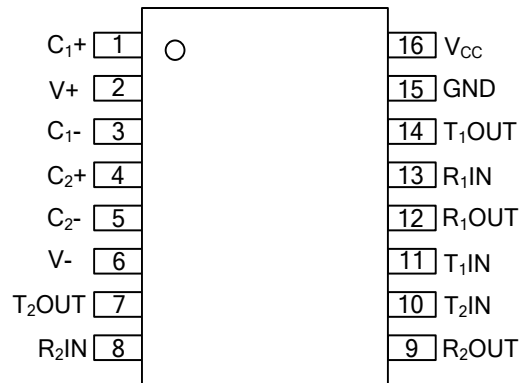

■ PIN DESCRIPTION

PIN NO.	PIN NAME	DESCRIPTION
1	C ₁₊	Positive terminal of the voltage doubler Charge-Pump Capacitor
2	V ₊	Positive voltage generated by the charge pump
3	C ₁₋	Negative terminal of the voltage doubler Charge-Pump Capacitor
4	C ₂₊	Positive terminal of inverting Charge-Pump Capacitor
5	C ₂₋	Negative terminal of inverting Charge-Pump Capacitor
6	V ₋	Negative voltage generated by the charge pump
7	T ₂ OUT	RS-232 Transmitter Outputs
8	R ₂ IN	RS-232 Receiver Inputs
9	R ₂ OUT	TTL/CMOS Receiver Outputs
10	T ₂ IN	TTL/CMOS Transmitter Inputs
11	T ₁ IN	TTL/CMOS Transmitter Inputs
12	R ₁ OUT	TTL/CMOS Receiver Outputs
13	R ₁ IN	RS-232 Receiver Inputs
14	T ₁ OUT	RS-232 Transmitter Outputs
15	GND	Ground
16	V _{CC}	Power Supply

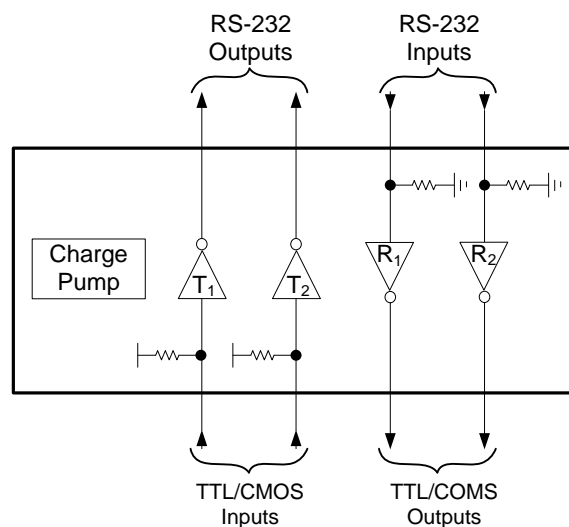

■ ABSOLUTE MAXIMUM RATINGS

PARAMETER	SYMBOL	RATINGS	UNIT
Supply voltage range	V _{CC}	-0.3 ~ +6.0	V
Positive-output supply voltage range	V+	-0.3 ~ +7.0	V
Negative-output supply voltage range	V-	+0.3 ~ -7.0	V
Input Voltages	T _{IN}	-0.3 ~ +6.0	V
	R _{IN}	-25 ~ +25	V
Output Voltages	T _{OUT}	-13.2 ~ +13.2	V
	R _{OUT}	-0.3 ~ V _{CC}	V
Short Circuit Duration	T _{OUT}	Continuous	
Power Dissipation	P _D	375	mW
Operating Temperature	T _{OPR}	0 ~ +70	°C

Note: 1. Absolute maximum ratings are those values beyond which the device could be permanently damaged. Absolute maximum ratings are stress ratings only and functional device operation is not implied.
 2. All voltages are with respect to network GND.

■ ELECTRICAL CHARACTERISTICS

(V_{CC}=+5.0V; T_A=+25°C; 0.1μF charge pump capacitors; T_{MIN} to T_{MAX} unless otherwise specified)

PARAMETER	SYMBOL	TEST CONDITIONS	MIN	TYP	MAX	UNIT	
TTL INPUT							
Logic Threshold	Low	V _{TL}	T _{IN} ; EN, SD			0.8	V
	High	V _{TH}	T _{IN} ; EN, SD	V _{CC} =3.3V V _{CC} =5.0V	2.0 2.4		V
Logic Pull up Current	I _{TH}	T _{IN} =0V		15	200	μA	
Maximum Data Rate		C _L =2500pF, R _L =3kΩ	120			kbps	
TTL OUTPUT							
TTL/CMOS Output Voltage	Low	V _{OL}	I _{OUT} =1.6mA; V _{CC} =+5.0V			0.4	V
	High	V _{OH}	I _{OUT} =-1.0mA	3.5			V
RS-232 OUTPUT							
Output Voltage Swing	V _{O(SW)}	All transmitter outputs loaded With 3kΩ to GND	±5.0	±6.0		V	
Output Resistance	R _O	V _{CC} =0V; V _{OUT} =±2.0V	300	10M		Ω	
Output Short Circuit Current	I _{O(SC)}	Infinite duration		±18		mA	
RS-232 INPUT							
Voltage Range	V _{I(SW)}		-25		+25	V	
Voltage Threshold	Low	V _{THR(L)}	V _{CC} =+5.0V, T _A =+25°C	0.8	1.2		V
	High	V _{THR(H)}			2.0	2.7	V
Hysteresis	V _{HYS}	V _{CC} =+5.0V, T _A =+25°C	0.2	0.5	1.0	V	
Resistance	R _I	T _A =+25°C, -15V ≤ V _{IN} ≤ +15V	3	5	8	kΩ	
DYNAMIC CHARACTERISTICS							
Propagation Delay, RS232 to TTL	t _{PD}			1.5		μs	
Instantaneous Slew Rate	SR	C _L =220pF, R _L =3kΩ-7kΩ; measured from +3V ~ -3V or -3V ~ +3V			35	V/μs	
Transition Region Slew Rate	SR	C _L =2500pF, R _L =3kΩ; measured from +3V ~ -3V or -3V ~ +3V		10		V/μs	
POWER REQUIREMENTS							
V _{CC} Power Supply Current	I _{CC}	No load, T _A =+25°C; V _{CC} =+5.0V		3.0	5.0	mA	
		All transmitters R _L =3kΩ, T _A =+25°C		25		mA	

■ FUNCTION DESCRIPTION

Driver/Transmitter

The drivers are inverting transmitters, which accept TTL or CMOS inputs and output the RS-232 signals with an inverted sense relative to the input logic levels. Typically the RS-232 output voltage swing is $\pm 6.0V$. Even under worst case loading conditions of $3k\Omega$ and $2500pF$, the output is guaranteed to be $\pm 5.0V$, which is consistent with the RS-232 standard specifications. The transmitter outputs are protected against infinite short-circuits to ground without degradation in reliability.

The instantaneous slew rate of the transmitter output is internally limited to a maximum of $35V/\mu s$. However, the transition region slew rate of these enhanced products is typically $10V/\mu s$. The smooth transition of the loaded output from VOL to VOH clearly meets the monotonicity requirements.

Receivers

The receivers convert RS-232 input signals to inverted TTL signals. Since the input is usually from a transmission line, where long cable lengths and system interference can degrade the signal, the inputs have a typical hysteresis margin of $0.5V$.

This ensures that the receiver is virtually immune to noisy transmission lines. The input thresholds are $0.8V$ minimum and $2.4V$ maximum, again well within the $\pm 3.0V$ RS-232 requirements. The receiver inputs are also protected against voltages up to $\pm 25V$. Should an input be left unconnected, a $5k\Omega$ pull down resistor to ground will commit the output of the receiver to a high state.

In actual system applications, it is quite possible for signals to be applied to the receiver inputs before power is applied to the receiver circuitry.

This occurs, for example, when a PC user attempts to print, only to realize the printer wasn't turned on. In this case an RS-232 signal from the PC will appear on the receiver input at the printer. When the printer power is turned on, the receiver will operate normally. All of these enhanced devices are fully protected.

Charge Pump

The charge pump section of the devices allows the circuit to operate from a single $+5.0V$ power supply by generating the required operating voltages internal to the devices. The charge pump consists of a voltage doubler and a voltage inverter. As shown in Figure 1, an internal oscillator triggers the charge accumulation and voltage inversion. The voltage doubler momentarily stores a charge on capacitor C1 equal to V_{CC} , referenced to ground. During the next transition of the oscillator this charge is boot-strapped to transfer charge to capacitor C3. The voltage across C3 is now from V_{CC} to $V+$.

In the inverter section as shown in Figure 2, the voltage across C3 is transferred to C2 forcing a range of $0V$ to $V+$ across C2. Boot-strapping of C2 will then transfer charge to C4 to generate $V-$. One of the significant enhancements over previous products of this type is that the values of the capacitors are no longer critical and have been decreased in size considerably to $0.1\mu F$. Because the charge pump runs at a much higher frequency, the $0.1\mu F$ capacitors are sufficient to transfer and sustain charges to the two transmitters.

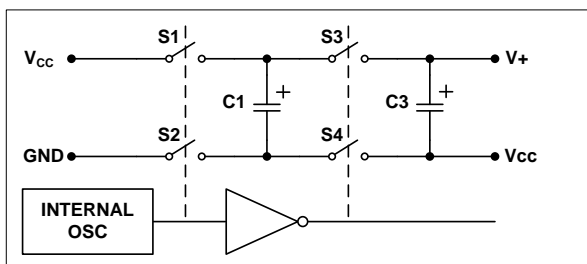

Figure 1 Charge Pump Voltage Doubler

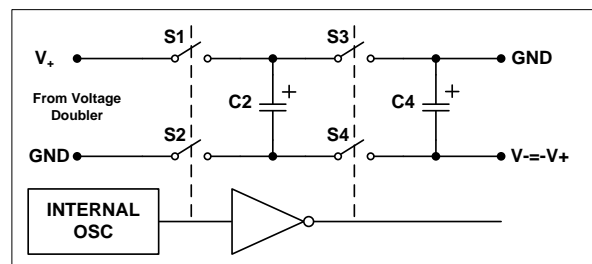
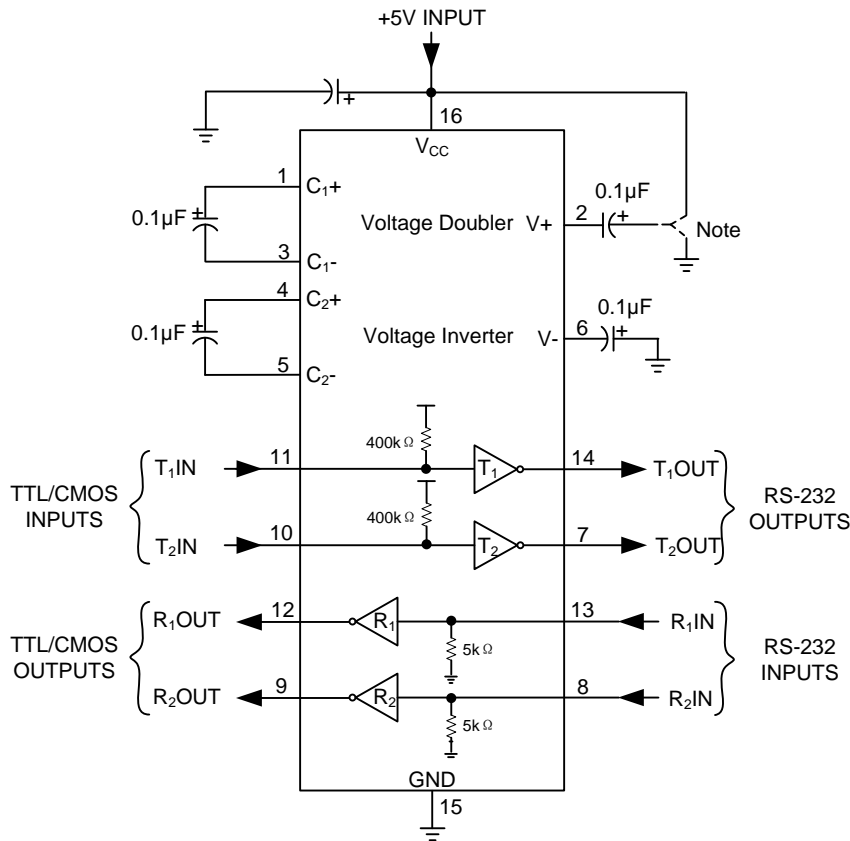

Figure 2 Charge Pump Voltage Inverter

APPLICATION INFORMATION

To operate from a single +5.0V supply, the UTC **UT232E** include charge pump voltage converters which can allow it. To generate the RS-232 output levels these converters convert the +5.0V input power to the $\pm 6.0V$ needed. The current drain due to charge pump operation is considerably reduced with this power supplied externally.



Note: The negative terminal of the V+ storage capacitor can be tied to either GND or V_{CC}

UTC assumes no responsibility for equipment failures that result from using products at values that exceed, even momentarily, rated values (such as maximum ratings, operating condition ranges, or other parameters) listed in products specifications of any and all UTC products described or contained herein. UTC products are not designed for use in life support appliances, devices or systems where malfunction of these products can be reasonably expected to result in personal injury. Reproduction in whole or in part is prohibited without the prior written consent of the copyright owner. UTC reserves the right to make changes to information published in this document, including without limitation specifications and product descriptions, at any time and without notice. This document supersedes and replaces all information supplied prior to the publication hereof.