

REVISIONS			DOC. NO. SPC-F004 * Effective: 7/8/02 * DCP No: 1398						
DCP #	REV	DESCRIPTION	DRAWN	DATE	CHECKD	DATE	APPRVD	DATE	
564	A	RELEASED	HYO	3/24/00	JC	7/27/00	DJC	8/7/00	
1892	B	UPDATE TO ROHS COMPLIANT	EO	03/15/06	HO	3/15/06	HO	3/15/06	

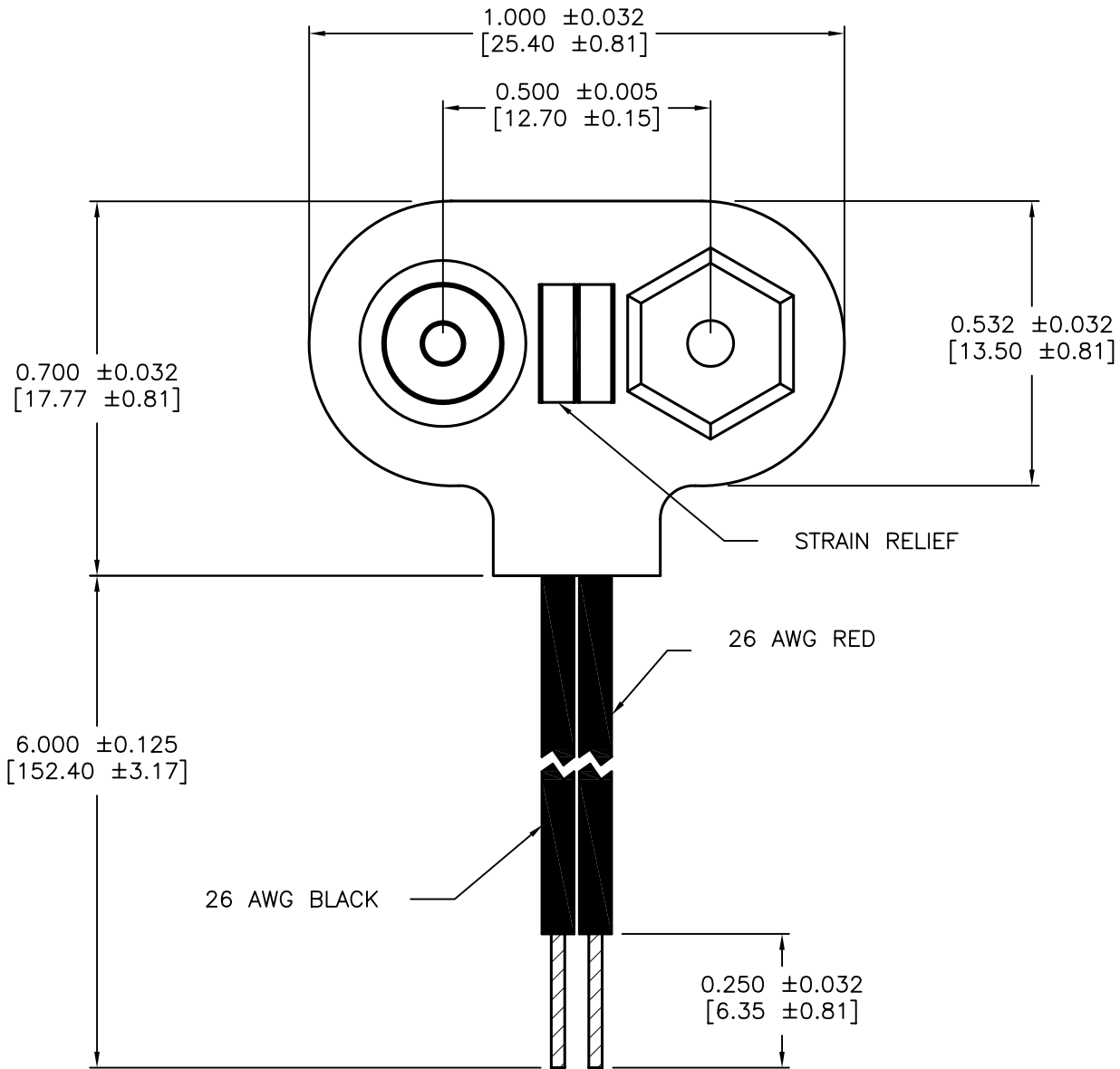

### Specifications

- 1- Wire: 26 AWG, 1007 UL/CSA approved
- 2- Contact: Brass, nickel plated, mounted on  
.012 [0.30] Min. thickness PVC  
& .032 [0.81] thick fiber insulation
- 3- Red wire connected to female contact
- 4- black wire connected to male contact.

SPC-F004.DWG

<b>TOLERANCES:</b>  UNLESS OTHERWISE SPECIFIED DECIMAL .XXX ± 0.015 [0.38]	<b>DRAWN BY:</b> HISHAM ODISH	<b>DATE:</b> 3/24/00	<b>DRAWING TITLE:</b> ECONOMY 9 VOLT BATTERY STRAP			
	<b>CHECKED BY:</b> JOHN COLE	<b>DATE:</b> 7/27/00	<b>SIZE</b> A	<b>DWG. NO.</b> 8459-0677	<b>ELECTRONIC FILE</b> 16N945.DWG	<b>REV</b> B
	<b>APPROVED BY:</b> DANIEL CAREY	<b>DATE:</b> 8/7/00	<b>SCALE:</b> NTS		<b>U.O.M.:</b> INCHES [mm]	<b>SHEET:</b> 1 OF 1