

SinglFuse™ SF-1206S Series Features

- Single blow fuse for overcurrent protection
- 3216 (EIA 1206) miniature footprint
- Slow blow fuse
- UL listed
- RoHS compliant* and halogen free**
- Thin film chip fuse
- Surface mount packaging for automated assembly

SF-1206S Series - Slow Blow Surface Mount Fuses

Electrical Characteristics

Model	Rated Current (Amps)	Fusing Time	Resistance (mΩ) Typ.***	Rated Voltage	Breaking Capacity	Typical I ² t (A ² s) ****
SF-1206S050	0.50	Open within 5 sec. at 250 % rated current	596	DC 63 V	DC 63 V 50 A	0.030
SF-1206S080	0.80		165			0.068
SF-1206S100	1.00		132			0.098
SF-1206S125	1.25		90			0.155
SF-1206S150	1.50		79			0.236
SF-1206S200	2.00		41			0.339
SF-1206S250	2.50		33	0.605		
SF-1206S300	3.00		23	0.933		
SF-1206S400	4.00		15.5	1.537		
SF-1206S500	5.00		13	2.533		
SF-1206S700	7.00	7	5.684	DC 32 V	DC 32 V 50 A	

*** Resistance value was measured with less than 10 % of rated current. Resistance tolerance is ±25 %.

****Typical I²t value is measured at 10x rated current.

Reliability Testing

Parameter	Requirement	Test Method
Carrying Capacity	No fusing	Rated current, 4 hours
Fusing Time	Within 5 seconds	250 % of its rated current
Interrupting Ability	No mechanical damages	After the fuse is interrupted, rated voltage applied for 30 seconds again
Bending Test	No mechanical damages	Distance between holding points: 90 mm, Bending: 3 mm, 1time, 30 seconds
Resistance to Solder Heat	±20 %	260 °C ±5 °C, 10 ±1 second
Solderability	95 % coverage minimum	235 °C ±5 °C, 2 ±0.5 second 245 °C ±5 °C, 2 ±0.5 second (lead free)
Temperature Rise	<75 °C	100 % of its rated current, measure of surface temperature
Resistance to Dry Heat	±20 %	105 °C ±5 °C, 1000 hours
Resistance to Solvent	No evident damage on protective coating and marking	23 °C ±5 °C of isopropyl alcohol, 90 seconds
Residual Resistance	10k ohms or more	Measure DC resistance after fusing
Thermal Shock	ΔR < 10 %	-20 °C / +25 °C / +125 °C / +25 °C, 10 cycles

Environmental Characteristics

Operating Temperature	-20 °C to +105 °C
Storage Conditions	
Temperature	+5 °C to +35 °C
Humidity	40 % to 75 %
Shelf Life	2 years from manufacturing date
Moisture Sensitivity Level	1
ESD Classification (HBM)	Class 6

BOURNS®

Asia-Pacific:

Tel: +886-2 2562-4117

Email: asiacus@bourns.com

Europe:

Tel: +36 88 520 390

Email: eurocus@bourns.com

The Americas:

Tel: +1-951 781-5500

Email: americus@bourns.com

www.bourns.com

* RoHS Directive 2002/95/EC Jan 27 2003 including Annex.

** Bourns is using the definition that appears to be the prevalent definition used as the industry standard at this time. The Bourns definition of "halogen-free" is: Bromine (Br) content: ≤ 900 ppm; Chlorine (Cl) content: ≤ 900 ppm; Total Br + Cl content: ≤ 1500 ppm.

"SinglFuse" is a trademark of Bourns, Inc.

Specifications are subject to change without notice.

The device characteristics and parameters in this data sheet can and do vary in different applications and actual device performance may vary over time.

Users should verify actual device performance in their specific applications.

SingFuse™ SF-1206S Series Applications

- Portable memory
- LCD monitors
- Disk drives
- PDAs
- Digital cameras
- DVDs
- Cell phones
- Rechargeable battery packs
- Battery chargers
- Set top boxes
- Industrial controllers

SF-1206S Series - Slow Blow Surface Mount Fuses **BOURNS®**

Typical Part Marking

Represents total content. Layout may vary.



RATING CURRENT (A)	
F = 0.50	T = 2.50
K = 0.80	3 = 3.00
L = 1.00	W = 4.00
M = 1.25	Y = 5.00
P = 1.50	Z = 7.00
S = 2.00	

How to Order

SF - 1206 S 050 - 2

SingFuse™ Product Designator _____

SMD Footprint _____
3216 (EIA 1206) size

Fuse Blow Type _____
F = Fast Acting FP = Fast Acting Precision
S = Slow Blow SP = Time Lag

Rated Current _____
050-700 (500 mA - 7.00 A)

Packaging Type _____
- 2 = Tape & Reel (5,000 pcs./reel)

Solder Reflow Recommendations

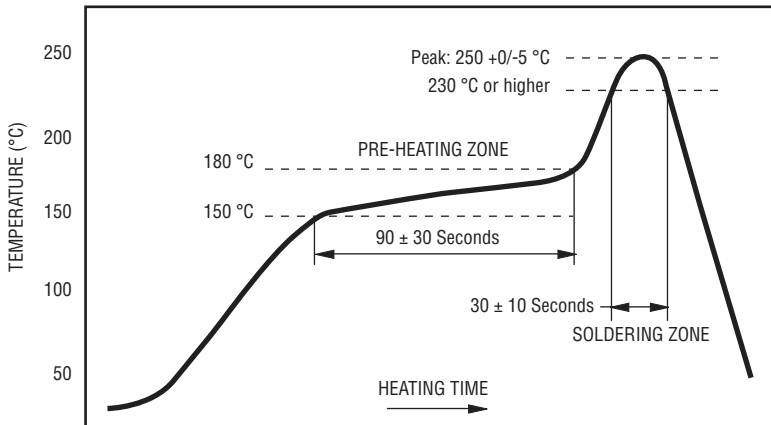

PEAK: 250 +0/-5 °C, 5 seconds
PRE-HEATING ZONE: 150 to 180 °C, 90 ± 30 seconds
SOLDERING ZONE: 230 °C or higher, 30 ± 10 seconds

Construction & Material Content

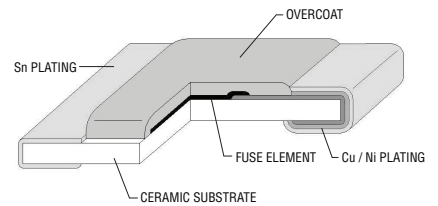

Product Dimensions

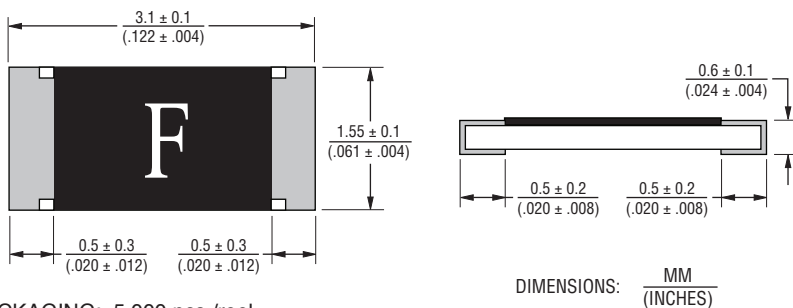

PACKAGING: 5,000 pcs./reel

Recommended Pad Layout

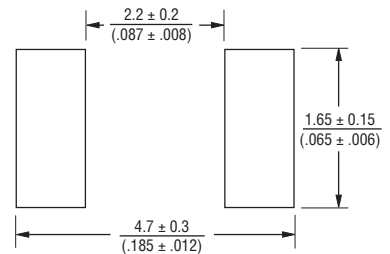

SF-1206S Series - Slow Blow Surface Mount Fuses



Average Time Current Curves

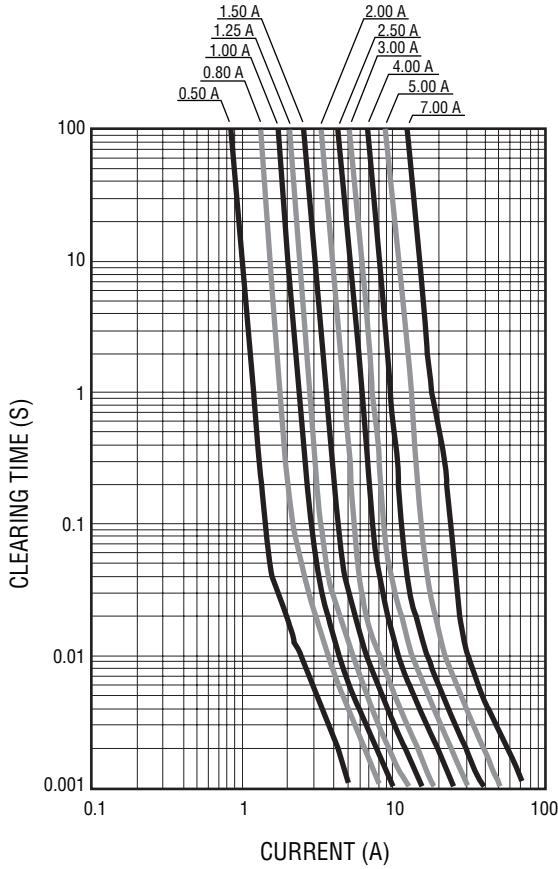

Minimum I²T V Clear Time Curves

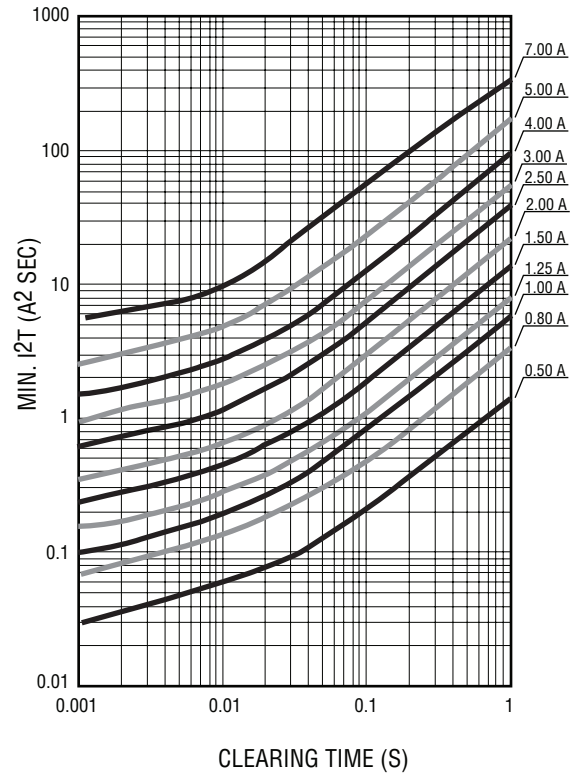

I²T Derating Curve by Repeater Rush Current

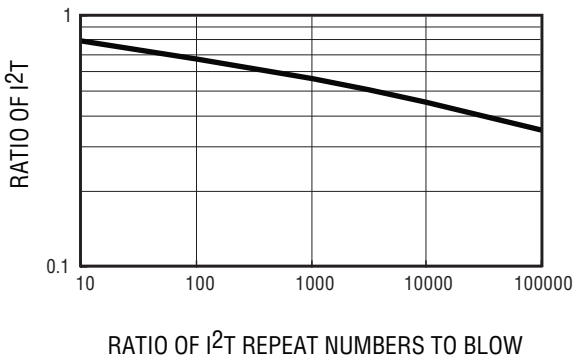

Thermal Derating Curve

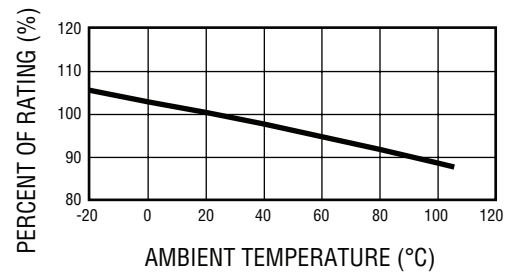

REV. F 07/17

Specifications are subject to change without notice.
 The device characteristics and parameters in this data sheet can and do vary in different applications and actual device performance may vary over time.
 Users should verify actual device performance in their specific applications.

SF-1206S Series Tape and Reel Specifications

BOURNS®

Tape Dimensions	SF-1206S Series per EIA 481-2
W	$\frac{8.0 \pm 0.2}{(.315 \pm .008)}$
P ₀	$\frac{4.0 \pm 0.1}{(.157 \pm .004)}$
P ₁	$\frac{4.0 \pm 0.1}{(.157 \pm .004)}$
P ₂	$\frac{2.0 \pm 0.05}{(.079 \pm .002)}$
A	$\frac{2.0 \pm 0.15}{(.079 \pm .006)}$
B	$\frac{3.6 \pm 0.2}{(.142 \pm .008)}$
F	$\frac{3.5 \pm 0.05}{(.138 \pm .002)}$
E	$\frac{1.75 \pm 0.1}{(.069 \pm .004)}$
D ₀	$\frac{1.5 + 0.1/-0}{(.059 + .004/-0)}$
T	$\frac{0.84 \pm 0.1}{(.033 \pm .004)}$
Reel Dimensions	
A	$\frac{180 +0/-3.0}{(7.087 +0/-1.18)}$
B Min.	$\frac{60.0}{(2.362)}$
C	$\frac{13.0 \pm 1.0}{(.512 \pm .039)}$
W	$\frac{9.0 \pm 1.0}{(.354 \pm .039)}$
T	$\frac{11.4 \pm 2.0}{(.449 \pm .079)}$

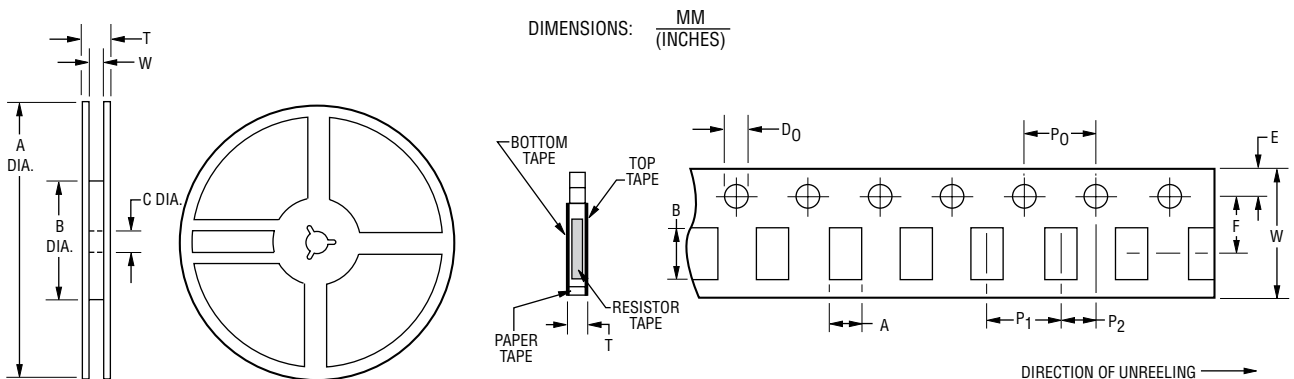

Specifications are subject to change without notice.

The device characteristics and parameters in this data sheet can and do vary in different applications and actual device performance may vary over time. Users should verify actual device performance in their specific applications.