

- 1
- 2
- 3
- 4
- 5
- 6
- 7
- 8
- 9
- 10
- 11
- 12
- 13
- 14
- 15
- 16
- 17
- 18

LEVER BODY

Die-cast zinc alloy, epoxy resin coating, RAL 9005 black colour, matte finish.

SUPPORT WASHER

Hardened and black-oxide steel.

STANDARD EXECUTIONS

Black-oxide steel clamping element and retaining screw. AISI 302 stainless steel return spring.

- **GN 307 (d1)**: threaded hole.
- **GN 307 (d1 - I2)**: threaded screw.

FEATURES AND APPLICATIONS

The adjustable hand levers with captive support washer are released by the rotation of the clamping element, so as not to mark the contact surfaces. One typical application is to use the hand lever for slots.

Adjustable hand levers GN 307 are ideal whenever parts have to be clamped in a confined space or in a particular lever position.

SPECIAL EXECUTIONS ON REQUEST

- Lever in different colours.

INSTRUCTIONS OF USE

To adjust while tightening, lift the lever to disengage the teeth of the clamping element and return it to the starting position. On releasing the handle the serrations re-engage automatically. When a 360° rotation of the lever is not possible, the clamping element can be easily screwed in (after having disengaged the lever), by turning the screw with hexagonal socket head.



Application example

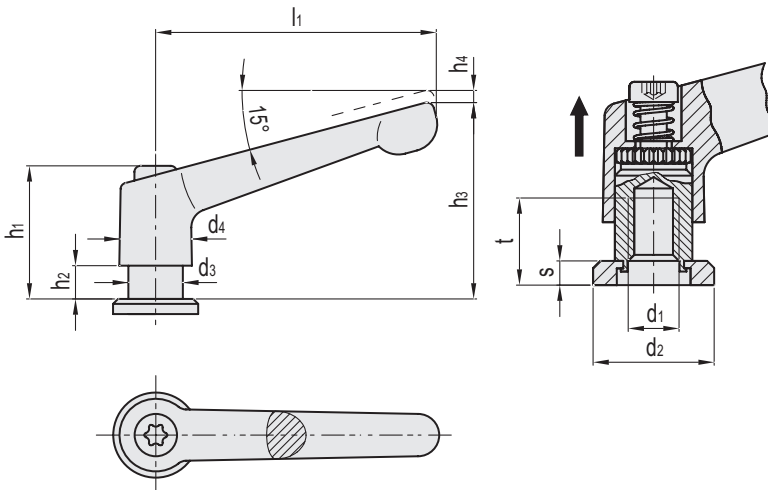
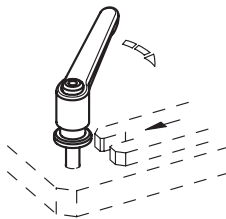

Clamping handles

GN 307 (d1)

Code	Description	l1	d1	d2	d3	d4	h1	h2	h3	h4	s	tmin	△
GN.14221	GN 307-30-M5-SW	30	M5	13	10	13	24.5	4	31	3.5	2.5	10	27
GN.14241	GN 307-45-M6-SW	45	M6	15	10	13	24.5	4	34	3.5	3	10	36
GN.14261	GN 307-63-M8-SW	63	M8	20	13.5	17.5	31	6.5	45	4	3.5	13	80
GN.14281	GN 307-78-M10-SW	78	M10	25	16	21	36	8	54	4	4	16	130

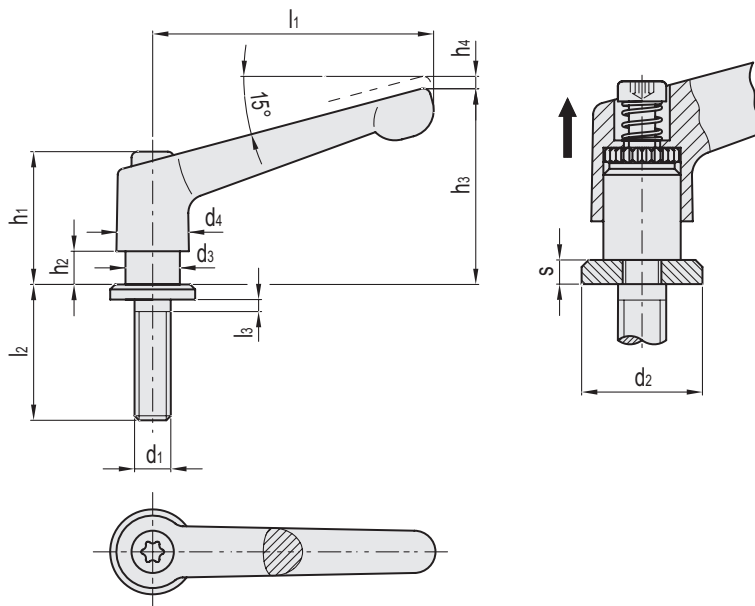

GN 307 (d1 - l2)

Code	Description	l1	d1	d2	d3	d4	h1	h2	h3	h4	l2	l3	s	⚖
GN.14223	GN 307-30-M5-12-SW	30	M5	13	10	13	24.5	4	31	3.5	12	0.4	2.5	30
GN.14225	GN 307-30-M5-16-SW	30	M5	13	10	13	24.5	4	31	3.5	16	0.4	2.5	30
GN.14227	GN 307-30-M5-20-SW	30	M5	13	10	13	24.5	4	31	3.5	20	0.4	2.5	31
GN.14229	GN 307-30-M5-25-SW	30	M5	13	10	13	24.5	4	31	3.5	25	0.4	2.5	31
GN.14231	GN 307-30-M5-32-SW	30	M5	13	10	13	24.5	4	31	3.5	32	0.4	2.5	32
GN.14243	GN 307-45-M6-16-SW	45	M6	15	10	13	24.5	4	34	3.5	16	0.4	3	40
GN.14245	GN 307-45-M6-20-SW	45	M6	15	10	13	24.5	4	34	3.5	20	0.4	3	41
GN.14247	GN 307-45-M6-25-SW	45	M6	15	10	13	24.5	4	34	3.5	25	0.4	3	42
GN.14249	GN 307-45-M6-32-SW	45	M6	15	10	13	24.5	4	34	3.5	32	0.4	3	43
GN.14251	GN 307-45-M6-40-SW	45	M6	15	10	13	24.5	4	34	3.5	40	0.4	3	44
GN.14263	GN 307-63-M8-20-SW	63	M8	20	13.5	17.5	31	6.5	45	4	20	0.4	3.5	93
GN.14265	GN 307-63-M8-25-SW	63	M8	20	13.5	17.5	31	6.5	45	4	25	0.4	3.5	92
GN.14267	GN 307-63-M8-32-SW	63	M8	20	13.5	17.5	31	6.5	45	4	32	0.4	3.5	95
GN.14269	GN 307-63-M8-40-SW	63	M8	20	13.5	17.5	31	6.5	45	4	40	0.4	3.5	97
GN.14271	GN 307-63-M8-50-SW	63	M8	20	13.5	17.5	31	6.5	45	4	50	0.4	3.5	100
GN.14283	GN 307-78-M10-20-SW	78	M10	25	16	21	36	12	54	4	20	0.5	4	149
GN.14285	GN 307-78-M10-25-SW	78	M10	25	16	21	36	12	54	4	25	0.5	4	151
GN.14287	GN 307-78-M10-32-SW	78	M10	25	16	21	36	12	54	4	32	0.5	4	155
GN.14289	GN 307-78-M10-40-SW	78	M10	25	16	21	36	12	54	4	40	0.5	4	159
GN.14291	GN 307-78-M10-50-SW	78	M10	25	16	21	36	12	54	4	50	0.5	4	164

