

# Direct Operated 2 Port Solenoid Valve **New**

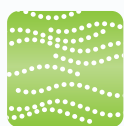

Air



Medium vacuum



Water



Oil

**Large flow rate**

Flow rate

**20% More flow\***

(Size 1)

**Compact**

Height

**10% Smaller\***

(Size 1)

**Lightweight**

Weight

**30% Lighter\***

(Size 1, Aluminium body)

\* Comparison with SMC conventional model

Conventional model **New VX**

**Body material**

**Air**  
Aluminium, Resin  
**Water/Oil/  
Medium vacuum**  
C37 (Brass),  
Stainless steel

**Enclosure**

**IP65\***

\* Electrical entry "Faston" type terminal is IP40.

With one-touch fittings (resin body)



Bracket  
Standard equipment

68 mm  
61 mm

**Power consumption**

**4.5 W** (Size 1)  
**7 W** (Size 2)  
**10.5 W** (Size 3)  
(DC)



**Series VX21/22/23**



CAT.EUS70-44A-UK

# Direct Operated 2 Port Solenoid Valve



**Enclosure**  
IP65

**Flame resistance**  
UL94V-0 conformed

**Low-noise construction**

Metal noise reduced by the rubber damper

**Piping variations**

Thread piping, one-touch fitting

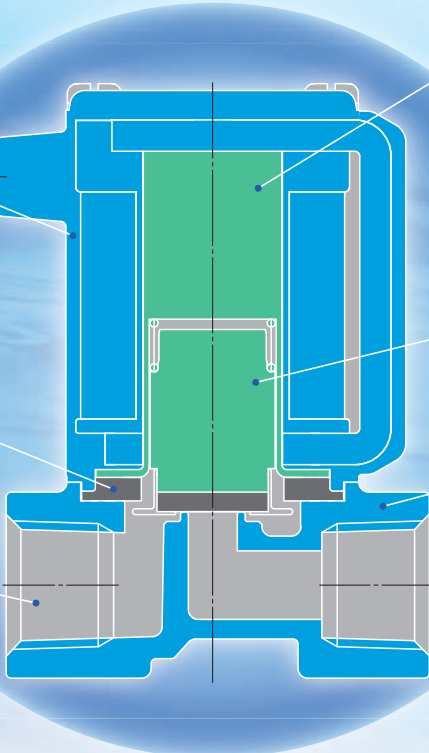

**Power consumption**

**4.5 W** (Size 1)

**7 W** (Size 2)

**10.5 W** (Size 3)

**Improved armature durability**

**Body material**

**Air** Aluminium, Resin

**Water/  
Oil/  
Medium vacuum** C37 (Brass),  
Stainless steel

## Built-in full-wave rectifier type (AC specification)

**Improved durability**

Service life is extended by the special construction. (compared with current shading coil)

**Reduced buzz noise**

Rectified to DC by the full-wave rectifier, resulting in a buzz noise reduction.

**Reduced apparent power**

10 VA → **7 VA** (Size 1)    20 VA → **9.5 VA** (Size 2)

32 VA → **12 VA** (Size 3)

**Improved OFF response**

Specially constructed to improve the OFF response when operated with a higher viscosity fluid such as oil.

**Low-noise construction**

Specially constructed to reduce the metal noise during operation.



### Normally Closed (N.C.)

Size	Orifice diameter							Port size
	2 mmø	3 mmø	4 mmø	5 mmø	7 mmø	8 mmø	10 mmø	
<b>Size 1</b>	●	●	—	●	—	—	—	1/8, 1/4 One-touch fitting: ø6, ø8
<b>Size 2</b>	—	—	●	—	●	—	—	1/4, 3/8 One-touch fitting: ø8, ø10
<b>Size 3</b>	—	—	—	●	—	●	●	1/4, 3/8, 1/2 One-touch fitting: ø10, ø12

# Series VX21/22/23

# Common Specifications/Selection Steps

## Standard Specifications

Valve specifications	Valve construction		Direct operated poppet
	Withstand pressure	MPa	2.0 (resin body type 1.5)
	Body material		Aluminium, Resin, C37 (Brass), Stainless steel
	Seal material		NBR, FKM
	Enclosure		Dusttight, Low jetproof (IP65) <small>Note 1)</small>
	Environment		Location without corrosive or explosive gases
Coil specifications	Rated voltage	AC	100 VAC, 200 VAC, 110 VAC, 230 VAC (220 VAC, 240 VAC, 48 VAC) <small>Note 2)</small>
		DC	24 VDC (12 VDC) <small>Note 2)</small>
	Allowable voltage fluctuation		±10% of rated voltage
	Allowable leakage voltage	AC (Built-in full-wave rectifier type)	10% or less of rated voltage
		DC	2% or less of rated voltage
Coil insulation type		Class B	

Note 1) Electrical entry "Faston" type terminal is IP40.

Note 2) Voltage in ( ) indicates special voltage. (Refer to page 10.)

**⚠ Be sure to read "Specific Product Precautions" before handling.**

## Solenoid Coil Specifications

### Normally Closed (N.C.)

#### DC Specification

Size	Power consumption (W) <small>Note 1)</small>	Temperature rise (C°) <small>Note 2)</small>
Size 1	4.5	50
Size 2	7	55
Size 3	10.5	65

Note 1) Power consumption, Apparent power: The value at ambient temperature of 20°C and when the rated voltage is applied. (Variation: ±10%)

Note 2) The value at ambient temperature of 20°C and when the rated voltage is applied. The value depends on the ambient environment. This is for reference.

#### AC Specification (Built-in Full-wave Rectifier Type)

Size	Apparent power (VA) <small>Note 1) 2)</small>	Temperature rise (C°) <small>Note 3)</small>
Size 1	7	60
Size 2	9.5	70
Size 3	12	70

Note 1) Power consumption, Apparent power: The value at ambient temperature of 20°C and when the rated voltage is applied. (Variation: ±10%)

Note 2) There is no difference in the frequency and the inrush and energised apparent power, since a rectifying circuit is used in the AC (built-in full-wave rectifier type).

Note 3) The value at ambient temperature of 20°C and when the rated voltage is applied. The value depends on the ambient environment. This is for reference.

## Selection Steps

### Step 1 Select the fluid.

Item	Selection item	Page	Symbol
Select the fluid.	Air	P. 2	0
	Water	P. 6	2
	Oil	P. 8	3
	Medium vacuum	P. 4	4

VX2 3 0 A A

### Step 2 Select "Body material", "Port size" and "Orifice diameter" from "Flow rate — Pressure" of each fluid.

Item	Selection item	Symbol
Select from "Flow rate — Pressure." • Body material • Port size • Orifice diameter	Size Size 3	3
	Body material Aluminium	A
	Port size 1/8	A
	Orifice diameter 2	A

VX2 3 0 A A

### Step 3 Select electrical specification.

Item	Selection item	Symbol
Select electrical specification.	Voltage 24 VDC	A
	Electrical entry Grommet	A

VX2 3 0 A A

### Step 4 For other special options, refer to page 10.

Specifications

For Air

For Medium Vacuum

For Water

For Oil

Construction

Dimensions

# Series VX21/22/23



## For Air Single Unit

### Model/Valve Specifications

N.C.

#### Passage symbol

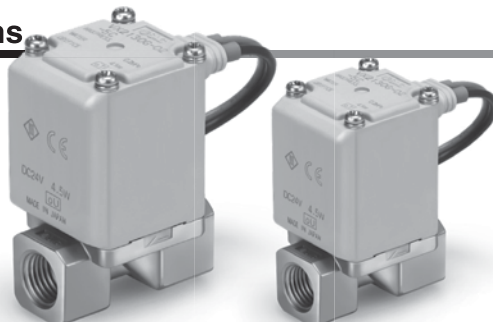
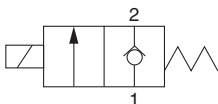

### Normally Closed (N.C.) Aluminum Body Type

Size	Port size	Orifice diameter (mmø)	Model	Flow-rate characteristics			Maximum operating pressure differential (MPa)	Weight <sup>Note)</sup> (g)
				C [dm <sup>3</sup> /(s·bar)]	b	Cv		
1	1/8, 1/4	2	VX210	0.63	0.63	0.23	1.0	220
		3		1.05	0.68	0.41	0.6	220
		5		2.20	0.39	0.62	0.2	220
2	1/4, 3/8	4	VX220	1.90	0.52	0.62	1.0	340
		7		3.99	0.44	1.08	0.15	340
3	1/4, 3/8	5	VX230	1.96	0.55	0.75	1.0	450
		8		5.67	0.33	1.58	0.3	450
		10		5.74	0.64	2.21	0.1	450
	1/2	10		8.42	0.39	2.21	0.1	470

### Resin Body Type (Built-in One-touch Fittings)

Size	Port size	Orifice diameter (mmø)	Model	Flow-rate characteristics			Maximum operating pressure differential (MPa)	Weight <sup>Note)</sup> (g)
				C [dm <sup>3</sup> /(s·bar)]	b	Cv		
1	C6	2	VX210	0.82	0.44	0.23	1.0	220
		3		1.25	0.34	0.35	0.6	220
		5		1.45	0.43	0.40	0.2	220
	C8	2		0.82	0.44	0.23	1.0	220
		3		1.81	0.40	0.41	0.6	220
		5		2.11	0.32	0.56	0.2	220
2	C8	4	VX220	1.69	0.40	0.47	1.0	340
		7		3.14	0.34	0.84	0.15	340
	C10	4		1.68	0.49	0.50	1.0	340
		7		3.54	0.36	0.90	0.15	340
3	C10	5	VX230	2.50	0.44	0.70	1.0	460
		8		2.77	0.82	1.22	0.3	460
		10		5.69	0.46	1.54	0.1	460
	C12	5		2.50	0.44	0.70	1.0	460
		8		2.56	0.88	1.38	0.3	460
		10		5.69	0.64	1.76	0.1	460

Note) Weight of grommet type. Add 10 g for conduit type, 30 g for DIN terminal type, 60 g for conduit terminal type respectively.  
• Refer to "Glossary of Terms" on page 16 for details on the maximum operating pressure differential.

### Fluid and Ambient Temperature

Fluid temperature (°C)	Ambient temperature (°C)
-10 <sup>Note)</sup> to 60	-20 to 60

Note) Dew point temperature: -10°C or less

### Valve Leakage

#### Internal Leakage

Seal material	Leakage rate (Air) <sup>Note)</sup>
NBR	1 cm <sup>3</sup> /min or less (Aluminium body type)
	15 cm <sup>3</sup> /min or less (Resin body type)

#### External Leakage

Seal material	Leakage rate (Air) <sup>Note)</sup>
NBR	1 cm <sup>3</sup> /min or less (Aluminium body type)
	15 cm <sup>3</sup> /min or less (Resin body type)

Note) Leakage is the value at ambient temperature 20°C.



# Direct Operated 2 Port Solenoid Valve *Series VX21/22/23*



**For Air Single Unit**



## How to Order (Single Unit)

**VX2 1 0 A A A**

**Fluid**  
0 For air

**Thread type**

—	Rc
A	G
B	NPT

**Common Specifications**

Valve type	N.C.
Seal material	NBR
Coil insulation type	Class B

**Size/Valve type**

Symbol	Size	Valve type
1	Size 1	Single unit N.C.

**Body material/Port size/Orifice diameter**

Symbol	Body material	Port size	Orifice diameter	
A	Aluminium	1/8	2	
B			3	
C			5	
D			1/4	2
E				3
F	5			
H	Resin	ø6 one-touch fitting	2	
J			3	
K			5	
L			ø8 one-touch fitting	2
M				3
N	5			

Symbol	Size	Valve type
2	Size 2	Single unit N.C.

Symbol	Body material	Port size	Orifice diameter	
A	Aluminium	1/4	4	
B			7	
D			3/8	4
E				7
H	Resin	ø8 one-touch fitting	4	
J			7	
L			ø10 one-touch fitting	4
M				7

Symbol	Size	Valve type
3	Size 3	Single unit N.C.

Symbol	Body material	Port size	Orifice diameter	
A	Aluminium	1/4	5	
B			8	
C			10	
D			3/8	5
E				8
F	10			
H	Resin	1/2	10	
J			ø10 one-touch fitting	5
K				8
L				10
M			ø12 one-touch fitting	5
N	8			
N			10	

**Voltage/Electrical entry**

Symbol	Voltage	Electrical entry
A	24 VDC	Grommet
B	100 VAC	Grommet (With surge voltage suppressor)
C	110 VAC	
D	200 VAC	
E	230 VAC	
F	24 VDC	
G	24 VDC	DIN terminal (With surge voltage suppressor)
H	100 VAC	
J	110 VAC	
K	200 VAC	
L	230 VAC	
M	24 VDC	Conduit terminal (With surge voltage suppressor)
N	100 VAC	
P	110 VAC	
Q	200 VAC	
R	230 VAC	
S	24 VDC	Conduit (With surge voltage suppressor)
T	100 VAC	
U	110 VAC	
V	200 VAC	
W	230 VAC	
Y	24 VDC	Faston terminal
Z	Other voltages and electrical options	

For other special options, refer to page 10.

Special voltage	48 VAC
	220 VAC
	240 VAC
	12 VDC
DIN terminal with light	
Conduit terminal with light	
Low concentration ozone resistant (Seal material: FKM)	
Oil-free	

Dimensions → Page 11 (Single unit)

Specifications  
 For Air  
 For Medium Vacuum  
 For Water  
 For Oil  
 Construction  
 Dimensions

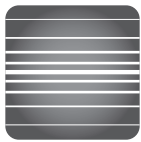

## For Medium Vacuum Single Unit

### Model/Valve Specifications

N.C.

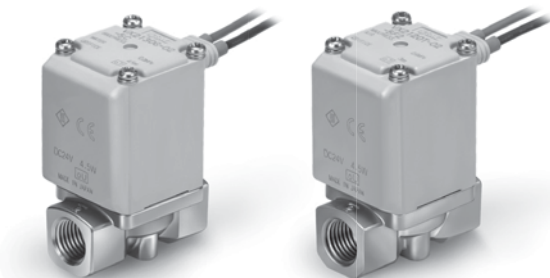

#### Passage symbol (Application example)

- ① Used with vacuum    ② Used with pressure

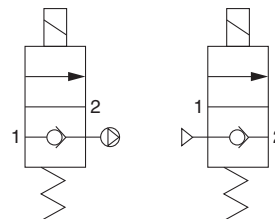

### Normally Closed (N.C.)

Size	Port size	Orifice diameter (mmø)	Model	Flow-rate characteristics			Operating pressure range		Weight (g) <sup>Note)</sup>
				C [dm <sup>3</sup> /(s·bar)]	b	Cv	① Used with vacuum (Pa-abs)	② Used with pressure (MPa)	
1	1/8, 1/4	2	VX214	0.63	0.63	0.23	0.1 to atmospheric pressure	0 to 1.0	220
		3		1.05	0.68	0.41		0 to 0.6	220
		5		2.20	0.39	0.62		0 to 0.2	220
2	1/4, 3/8	4	VX224	1.90	0.52	0.62		0 to 1.0	340
		7		3.99	0.44	1.08		0 to 0.15	340
3	1/4, 3/8	5	VX234	1.96	0.55	0.75		0 to 1.0	450
		8		5.67	0.33	1.58		0 to 0.3	450
		10		5.74	0.64	2.21		0 to 0.1	450
		1/2		8.42	0.39	2.21		0 to 0.1	470

Note) Weight of grommet type. Add 10 g for conduit type, 30 g for DIN terminal type, 60 g for conduit terminal type respectively.

### Fluid and Ambient Temperature

Fluid temperature (°C)	Ambient temperature (°C)
1 to 60	-20 to 60

Note) With no freezing

### Valve Leakage

#### Internal Leakage

Seal material	Leakage rate <sup>Note)</sup>
FKM	10 <sup>-6</sup> Pa·m <sup>3</sup> /sec or less

#### External Leakage

Seal material	Leakage rate <sup>Note)</sup>
FKM	10 <sup>-6</sup> Pa·m <sup>3</sup> /sec or less

Note) Leakage (10<sup>-6</sup>Pa·m<sup>3</sup>/sec) is the value at differential pressure 0.1 MPa and ambient temperature 20°C.

# Direct Operated 2 Port Solenoid Valve *Series VX21/22/23*

**For Medium Vacuum Single Unit**



## How to Order (Single Unit)

**VX2 1 4 A A A**

### Common Specifications

Valve type	N.C.
Seal material	FKM
Coil insulation type	Class B

### Thread type

—	Rc
A	G
B	NPT

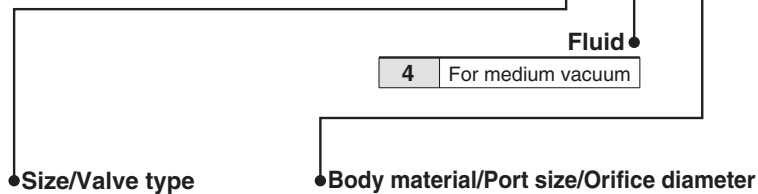

### Size/Valve type

Symbol	Size	Valve type
1	Size 1	Single unit N.C.

### Body material/Port size/Orifice diameter

Symbol	Body material	Port size	Orifice diameter
A	C37 (Brass)	1/8	2
B			3
C			5
D		1/4	2
E			3
F			5
H	Stainless steel	1/8	2
J			3
K			5
L		1/4	2
M			3
N			5

### Voltage/Electrical entry

Symbol	Voltage	Electrical entry
A	24 VDC	Grommet
B	100 VAC	Grommet (With surge voltage suppressor)
C	110 VAC	
D	200 VAC	
E	230 VAC	
F	24 VDC	DIN terminal (With surge voltage suppressor)
G	24 VDC	
H	100 VAC	
J	110 VAC	
K	200 VAC	
L	230 VAC	
M	24 VDC	Conduit terminal (With surge voltage suppressor)
N	100 VAC	
P	110 VAC	
Q	200 VAC	
R	230 VAC	Conduit (With surge voltage suppressor)
S	24 VDC	
T	100 VAC	
U	110 VAC	
V	200 VAC	
W	230 VAC	
Y	24 VDC	Faston terminal
Z	Other voltages and electrical options	

Symbol	Size	Valve type
2	Size 2	Single unit N.C.

Symbol	Body material	Port size	Orifice diameter
A	C37 (Brass)	1/4	4
B			7
D		3/8	4
E			7
H	Stainless steel	1/4	4
J			7
L			4
M		3/8	4
			7
			7

Symbol	Size	Valve type
3	Size 3	Single unit N.C.

Symbol	Body material	Port size	Orifice diameter	
A	C37 (Brass)	1/4	5	
B			8	
C			10	
D		3/8	5	
E			8	
F			10	
G	Stainless steel	1/2	10	
H			1/4	5
J				8
K		10		
L		3/8	5	
M			8	
N	10			
P	1/2	10		

For other special options, refer to page 10.

Special voltage	48 VAC
	220 VAC
	240 VAC
	12 VDC
DIN terminal with light	
Conduit terminal with light	
Bracket interchangeable with old type	

# Series VX21/22/23



## For Water Single Unit

### Model/Valve Specifications

N.C.

#### Passage symbol

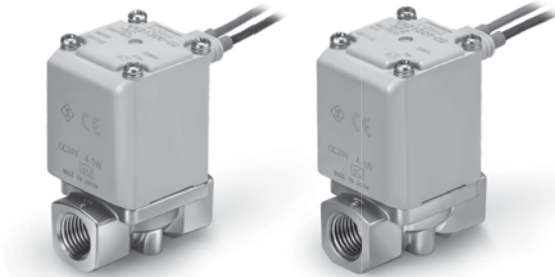
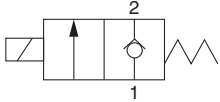

#### Normally Closed (N.C.)

Size	Port size	Orifice diameter (mmø)	Model	Flow-rate characteristics		Maximum operating pressure differential (MPa)	Weight <sup>Note)</sup> (g)
				AV	Conversion Cv		
1	1/8, 1/4	2	VX212	5.5	0.23	1	300
		3		10.0	0.42	0.6	300
		5		15.0	0.63	0.2	300
2	1/4, 3/8	4	VX222	15.0	0.63	1	460
		7		26.0	1.08	0.15	460
3	1/4, 3/8	5	VX232	18.0	0.75	1	580
		8		38.0	1.58	0.3	580
		10		53.0	2.21	0.1	580
	1/2	10		53.0	2.21	0.1	630



Note) Weight of grommet type. Add 10 g for conduit type, 30 g for DIN terminal type, 60 g for conduit terminal type respectively.  
 • Refer to "Glossary of Terms" on page 16 for details on the maximum operating pressure differential.

### Fluid and Ambient Temperature

Fluid temperature (°C)	Ambient temperature (°C)
1 to 60	-20 to 60



Note) With no freezing

### Valve Leakage

#### Internal Leakage

Seal material	Leakage rate (Water) <sup>Note)</sup>
NBR	0.1 cm <sup>3</sup> /min or less

#### External Leakage

Seal material	Leakage rate (Water) <sup>Note)</sup>
NBR	0.1 cm <sup>3</sup> /min or less



Note) Leakage is the value at ambient temperature 20°C.



# Direct Operated 2 Port Solenoid Valve Series VX21/22/23



**For Water Single Unit**



## How to Order (Single Unit)

VX2 1 2 A A A

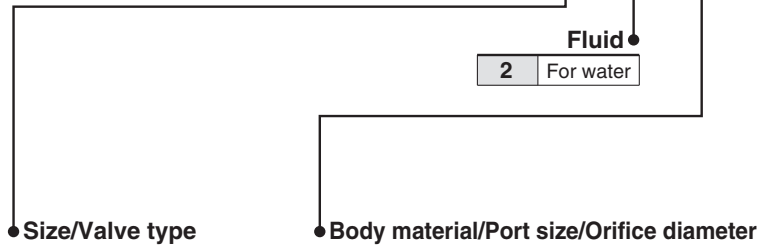

### Common Specifications

Valve type	N.C.
Seal material	NBR
Coil insulation type	Class B

### Thread type

—	Rc
A	G
B	NPT

### Size/Valve type

Symbol	Size	Valve type
1	Size 1	Single unit N.C.

### Body material/Port size/Orifice diameter

Symbol	Body material	Port size	Orifice diameter
A	C37 (Brass)	1/8	2
B			3
C			5
D		1/4	2
E			3
F			5
H	Stainless steel	1/8	2
J			3
K			5
L		1/4	2
M			3
N			5

### Voltage/Electrical entry

Symbol	Voltage	Electrical entry
A	24 VDC	Grommet
B	100 VAC	Grommet (With surge voltage suppressor)
C	110 VAC	
D	200 VAC	
E	230 VAC	DIN terminal (With surge voltage suppressor)
F	24 VDC	
G	24 VDC	
H	100 VAC	
J	110 VAC	Conduit terminal (With surge voltage suppressor)
K	200 VAC	
L	230 VAC	
M	24 VDC	Conduit terminal (With surge voltage suppressor)
N	100 VAC	
P	110 VAC	
Q	200 VAC	Conduit (With surge voltage suppressor)
R	230 VAC	
S	24 VDC	
T	100 VAC	Conduit (With surge voltage suppressor)
U	110 VAC	
V	200 VAC	
W	230 VAC	Faston terminal
Y	24 VDC	
Z	Other voltages and electrical options	

Symbol	Size	Valve type
2	Size 2	Single unit N.C.

Symbol	Body material	Port size	Orifice diameter
A	C37 (Brass)	1/4	4
B			7
D		3/8	4
E			7
H	Stainless steel	1/4	4
J			7
L		3/8	4
M			7

Symbol	Size	Valve type
3	Size 3	Single unit N.C.

Symbol	Body material	Port size	Orifice diameter
A	C37 (Brass)	1/4	5
B			8
C			10
D		3/8	5
E			8
F			10
G	1/2	10	
H		1/4	5
J			8
K	10		
L	Stainless steel	1/4	5
M			8
N		3/8	10
P			10

For other special options, refer to page 10.

Special voltage	48 VAC
	220 VAC
	240 VAC
	12 VDC
DIN terminal with light	
Conduit terminal with light	
Oil-free	
Bracket interchangeable with old type	

Dimensions → Page 11 (Single unit)

# Series VX21/22/23



## For Oil Single Unit

### ⚠ When the fluid is oil.

The kinematic viscosity must not exceed 50 mm<sup>2</sup>/s. The special construction of the armature adopted in the built-in full-wave rectifier type gives an improvement in OFF response by providing clearance on the absorbed surface when it is switched ON.

## Model/Valve Specifications

N.C.

### Passage symbol

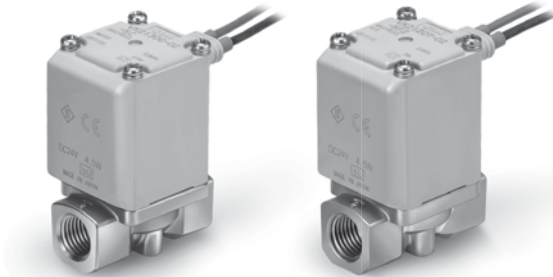
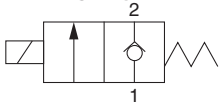

### Normally Closed (N.C.)

Size	Port size	Orifice diameter (mmø)	Model	Flow-rate characteristics		Maximum operating pressure differential (MPa)	Weight <sup>Note)</sup> (g)
				AV	Conversion Cv		
1	1/8, 1/4	2	VX213	5.5	0.23	1	300
		3		10.0	0.42	0.6	300
		5		15.0	0.63	0.2	300
2	1/4, 3/8	4	VX223	15.0	0.63	1	460
		7		26.0	1.08	0.15	460
3	1/4, 3/8	5	VX233	18.0	0.75	1	580
		8		38.0	1.58	0.3	580
		10		53.0	2.21	0.1	580
	1/2	10		53.0	2.21	0.1	630

Note) Weight of grommet type. Add 10 g for conduit type, 30 g for DIN terminal type, 60 g for conduit terminal type respectively.  
 • Refer to "Glossary of Terms" on page 16 for details on the maximum operating pressure differential.

## Fluid and Ambient Temperature

Fluid temperature (°C)	Ambient temperature (°C)
-5 <sup>Note)</sup> to 60	-20 to 60

Note) Kinematic viscosity: 50 mm<sup>2</sup>/s or less

## Valve Leakage

### Internal Leakage

Seal material	Leakage rate (Oil) <sup>Note)</sup>
FKM	0.1 cm <sup>3</sup> /min or less

### External Leakage

Seal material	Leakage rate (Oil) <sup>Note)</sup>
FKM	0.1 cm <sup>3</sup> /min or less

Note) Leakage is the value at ambient temperature 20°C.

# Direct Operated 2 Port Solenoid Valve *Series VX21/22/23*

 **For Oil Single Unit**



## How to Order (Single Unit)

**VX2** **1** **3** **A** **A** **A**

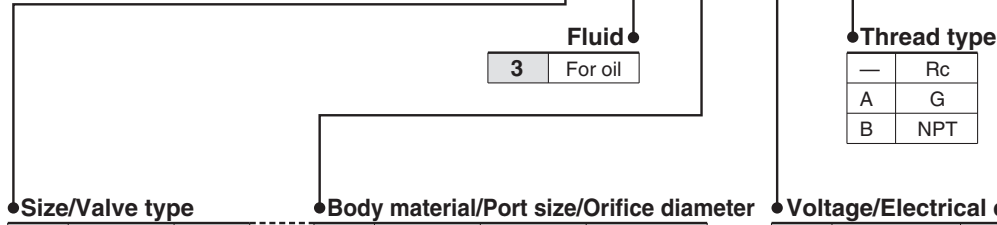

### Common Specifications

Valve type	N.C.
Seal material	FKM
Coil insulation type	Class B

Symbol	Size	Valve type	Symbol	Body material	Port size	Orifice diameter					
1	Size 1	Single unit N.C.	A	C37 (Brass)	1/8	2					
			B			3					
			C			5					
			D			1/4	2				
			E				3				
			F				5				
			H	Stainless steel	1/8	2					
			J			3					
			K			5					
			L			1/4	2				
			M				3				
			N				5				
			N				5				
			2			Size 2	Single unit N.C.	A	C37 (Brass)	1/4	4
B	7										
D	4										
E	7										
H	Stainless steel	1/4		4							
J				7							
L				3/8	4						
M					7						
3				Size 3	Single unit N.C.			A	C37 (Brass)	1/4	5
								B			8
	C	10									
	D	3/8	5								
	E		8								
	F		10								
	G	Stainless steel	1/2			10					
	H					1/4	5				
	J						8				
	K						10				
	L						3/8	5			
	M					8					
	N	1/2	1/2			10					
	P					10					

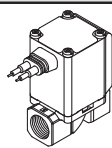
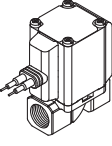
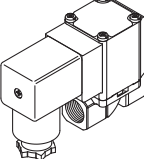
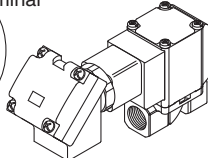
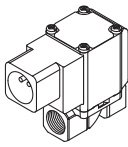
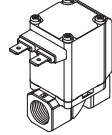
Symbol	Voltage	Electrical entry					
A	24 VDC	Grommet 					
		Grommet (With surge voltage suppressor) 					
			B	100 VAC			
			C	110 VAC			
			D	200 VAC			
			E	230 VAC			
G	24 VDC		DIN terminal (With surge voltage suppressor) 				
		H		100 VAC			
		J		110 VAC			
		K		200 VAC			
		L		230 VAC			
		M		24 VDC	Conduit terminal (With surge voltage suppressor) 		
						N	100 VAC
						P	110 VAC
						Q	200 VAC
						R	230 VAC
S	24 VDC		Conduit (With surge voltage suppressor) 				
		T		100 VAC			
		U		110 VAC			
		V		200 VAC			
		W		230 VAC			
		Y		24 VDC	Faston terminal 		
						Z	Other voltages and electrical options

For other special options, refer to page 10.

Special voltage	48 VAC
	220 VAC
	240 VAC
	12 VDC
DIN terminal with light	
Conduit terminal with light	
Oil-free	
Bracket interchangeable with old type	



# Direct Operated 2 Port Solenoid Valve *Series VX21/22/23*



## Dimensions: Body Material: Aluminium

### Grommet (DC)

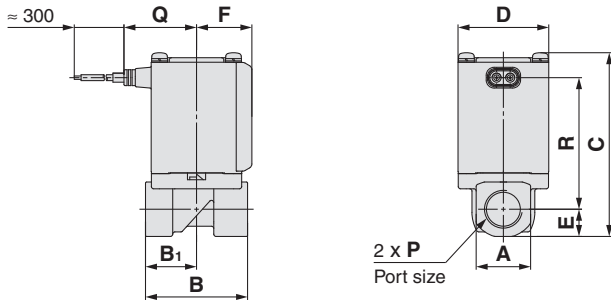

### Grommet (with surge voltage suppressor)

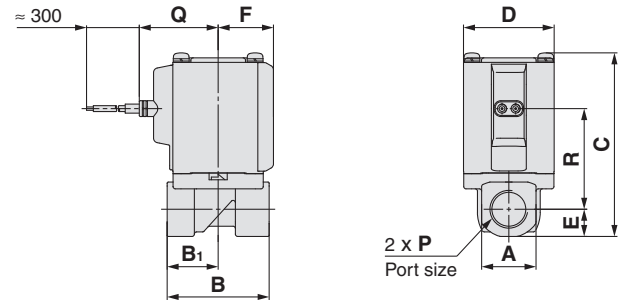

### DIN terminal

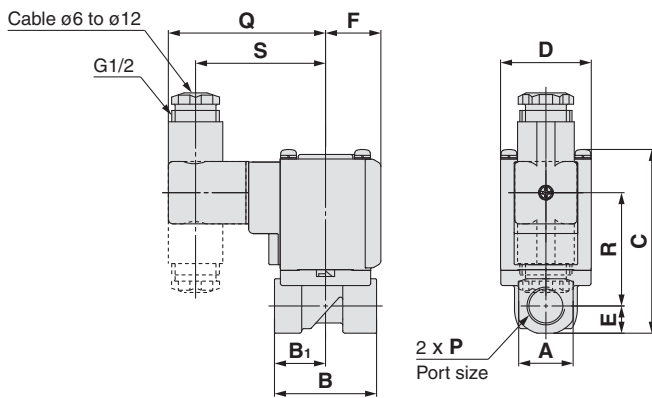

### Conduit terminal

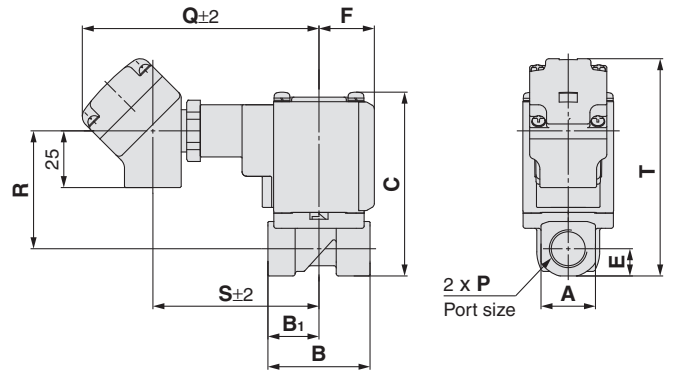

### Conduit

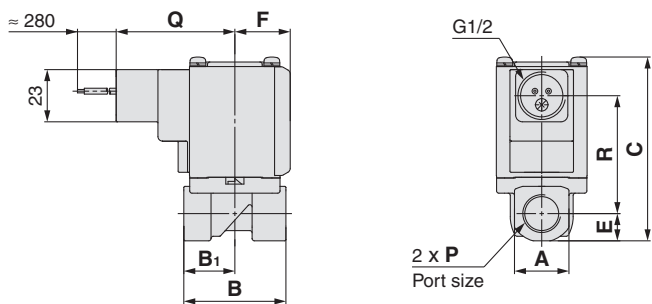

### Faston type

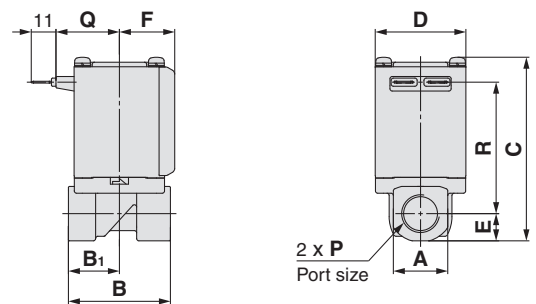

Size	Port size P	A	B	B <sub>1</sub>	C	D	E	F	Electrical entry			
									Grommet		Grommet (with surge voltage suppressor)	
									Q	R	Q	R
1	1/8, 1/4	19	43	21	61	30	9.5	20	27	42	30	28.5
2	1/4, 3/8	24	45	22.5	76	35	12	22	29.5	53.5	32.5	39.5
3	1/4, 3/8	24	45	22.5	81	40	12	24.5	32	58	35	44.5
	1/2	30	50	25	86.5	40	15	24.5	32	61	35	47.5

Size	Port size P	Electrical entry										
		DIN terminal			Conduit terminal				Conduit		Faston type	
		Q	R	S	Q	R	S	T	Q	R	Q	R
1	1/8, 1/4	64.5	34	52.5	99.5	36	68.5	77	47.5	36	23	42
2	1/4, 3/8	67	45	55	102	47	71	91	50	47	25.5	53.5
3	1/4, 3/8	69.5	50	57.5	104.5	52	73.5	96	52.5	52	28	58
	1/2	69.5	53	57.5	104.5	55	73.5	101.5	52.5	55	28	61

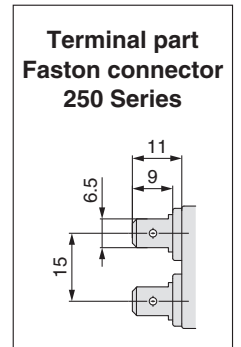

Specifications

For Air

For Medium Vacuum

For Water

For Oil

Construction

Dimensions

# Series VX21/22/23



For Air, Medium Vacuum, Water, Oil

## Dimensions: Body Material: Resin

### Grommet

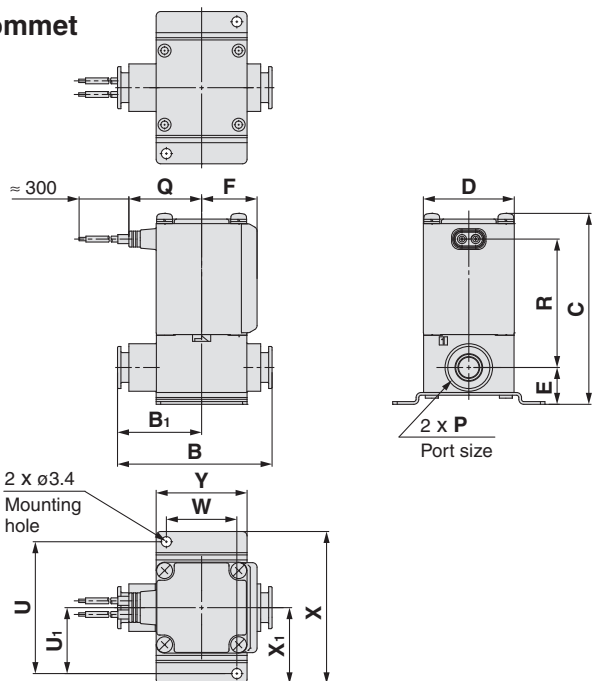

### Grommet (with surge voltage suppressor)

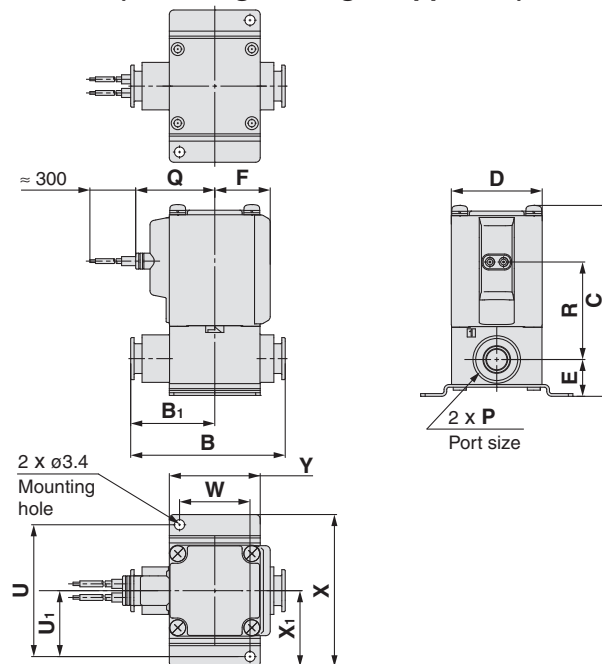

### DIN terminal

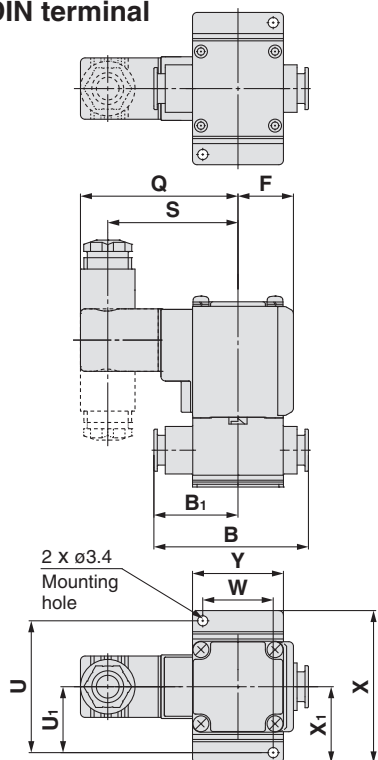

### Conduit terminal

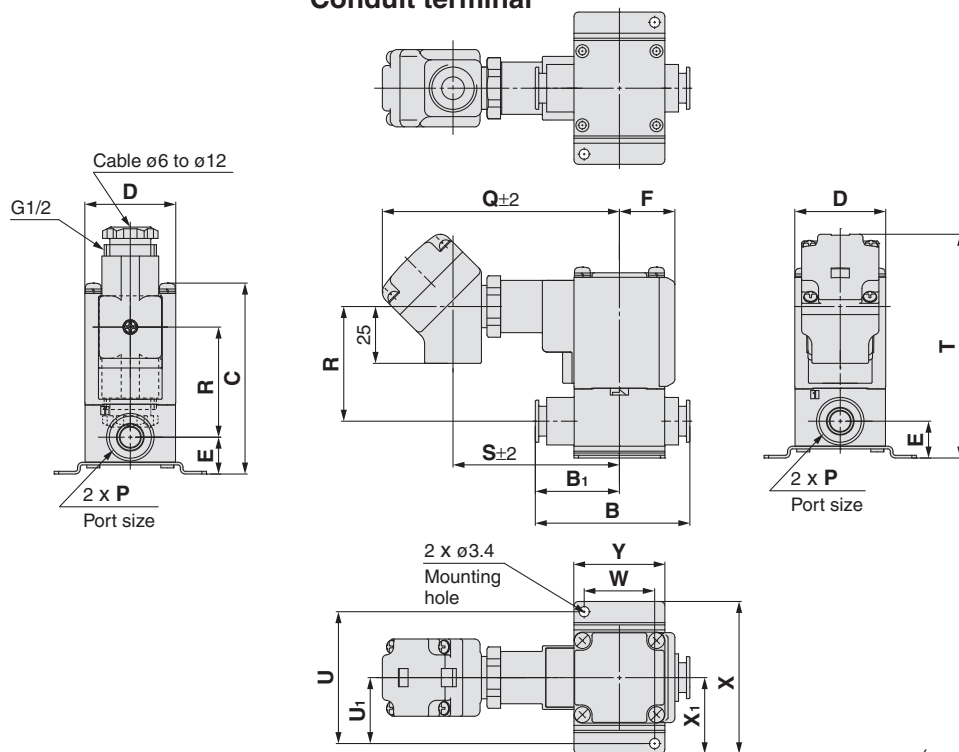

For information on handling one-touch fittings and appropriate tubing, refer to page 25 and KQ2 series. The KQ2 series information can be downloaded from the following SMC website, <http://www.smc.eu>

Size	One-touch fitting P	B	B <sub>1</sub>	C	D	E	F	Mounting bracket dimensions					
								U	U <sub>1</sub>	W	X	X <sub>1</sub>	Y
1	C6, C8	53.5	29	65.5	30	13.5	20	45	22.5	22	52	26	30
2	C8, C10	66	36	76.5	35	15	22	53	26.5	27	62	31	35
3	C10, C12	68	37	84	40	16.5	24.5	58	29	31	67	33.5	40

Size	One-touch fitting P	Electrical entry											
		Grommet		Grommet (with surge voltage suppressor)		DIN terminal			Conduit terminal				
		Q	R	Q	R	Q	R	S	Q	R	S	T	
1	C6, C8	27	42.5	30	29	64.5	34.5	52.5	99.5	36.5	68.5	81.5	
2	C8, C10	29.5	51	32.5	37	67	43	55	102	45	71	91.5	
3	C10, C12	32	56.5	35	43	69.5	48.5	57.5	104.5	50.5	73.5	98.5	





**Dimensions: Body Material: Resin**

**Conduit**

**Faston type**

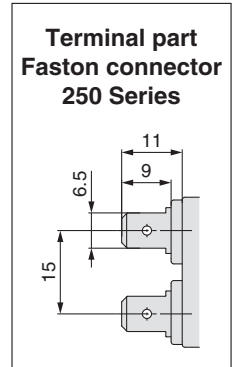
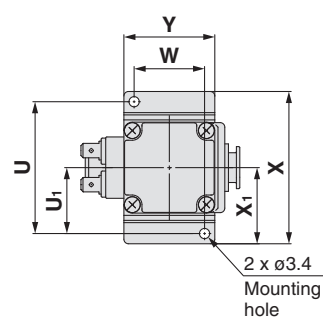
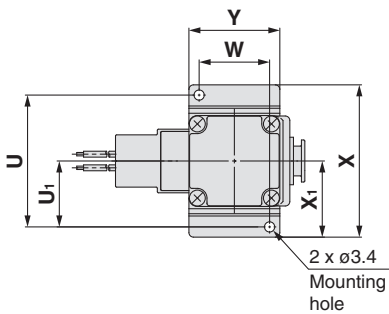
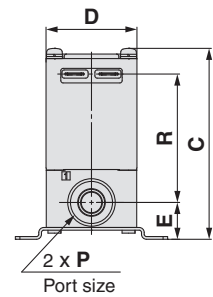
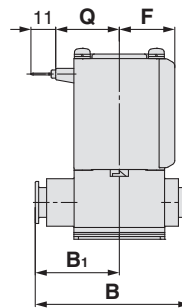
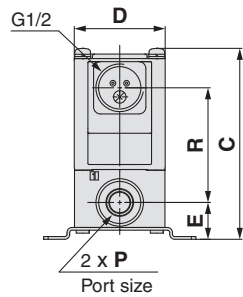
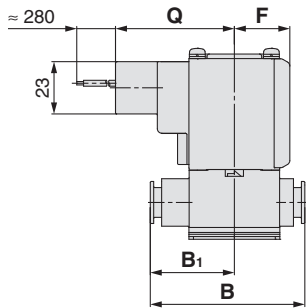
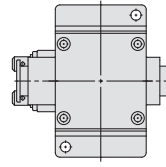
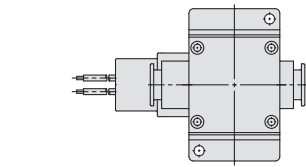

Size	One-touch fitting <b>P</b>	<b>B</b>	<b>B<sub>1</sub></b>	<b>C</b>	<b>D</b>	<b>E</b>	<b>F</b>	Mounting bracket dimensions						Electrical entry			
														Conduit		Faston type	
								<b>U</b>	<b>U<sub>1</sub></b>	<b>W</b>	<b>X</b>	<b>X<sub>1</sub></b>	<b>Y</b>	<b>Q</b>	<b>R</b>	<b>Q</b>	<b>R</b>
<b>1</b>	C6, C8	53.5	29	65.5	30	13.5	20	45	22.5	22	52	26	30	47.5	36.5	23	42.5
<b>2</b>	C8, C10	66	36	76.5	35	15	22	53	26.5	27	62	31	35	50	45	25.5	51
<b>3</b>	C10, C12	68	37	84	40	16.5	24.5	58	29	31	67	33.5	40	52.5	50.5	28	56.5

Specifications

For Air

For Medium Vacuum

For Water

For Oil

Construction

Dimensions

# Series VX21/22/23



For Air, Medium Vacuum, Water, Oil

**Dimensions: Body Material: C37 (Brass), Stainless Steel**

## Grommet

## Grommet (with surge voltage suppressor)

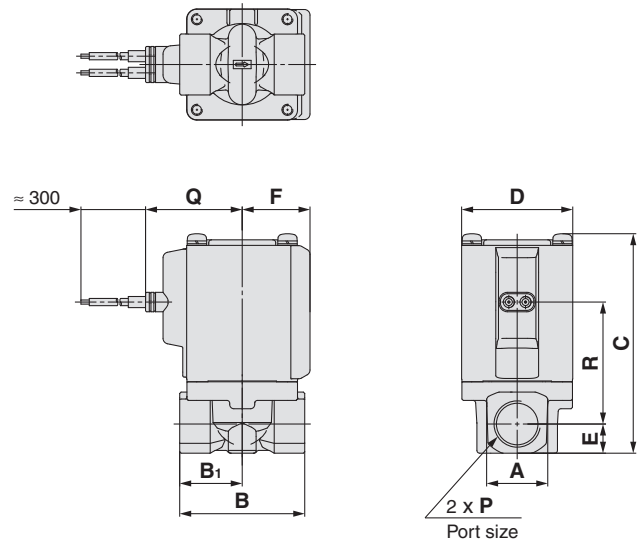
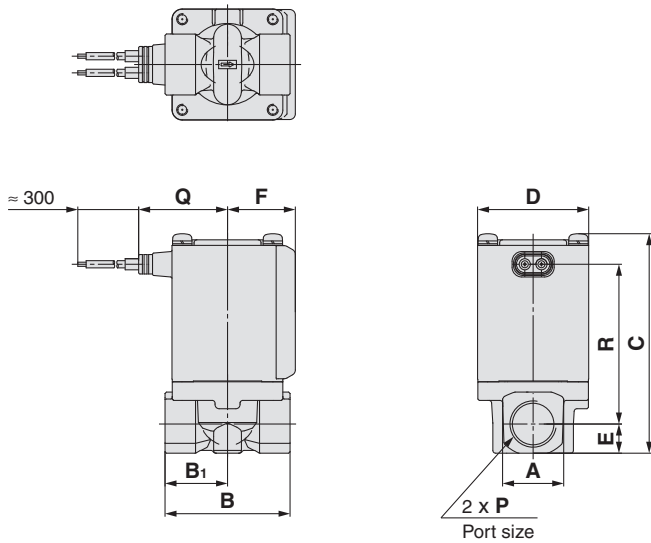

## DIN terminal

## Conduit terminal

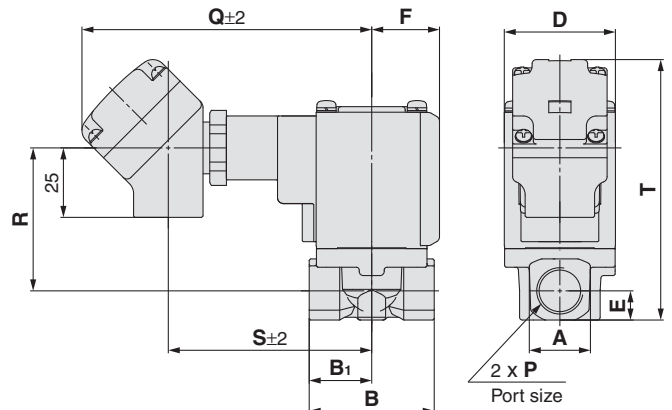
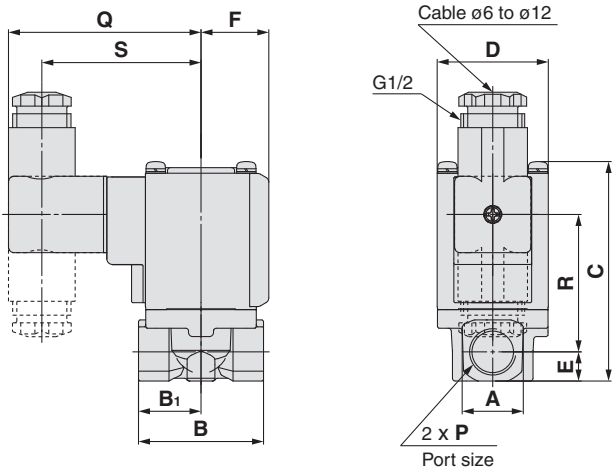
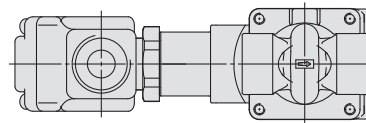
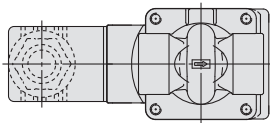

Size	Port size P	A	B	B <sub>1</sub>	C	D	E	F	Electrical entry (mm)										
									Grommet		Grommet (with surge voltage suppressor)		DIN terminal			Conduit terminal			
									Q	R	Q	R	Q	R	S	Q	R	S	T
1	1/8, 1/4	19	43	21	61	30	9.5	20	27	42	30	28.5	64.5	34	52.5	99.5	36	68.5	77
2	1/4, 3/8	22	45	22.5	74.5	35	10.5	22	29.5	53.5	32.5	39.5	67	45	55	102	47	71	89.5
3	1/4, 3/8	22	45	22.5	79	40	10.5	24.5	32	57.5	35	44	69.5	49.5	57.5	104.5	51.5	73.5	94
	1/2	29.5	50	25	85.5	40	14	24.5	32	61	35	47.5	69.5	53	57.5	104.5	55	73.5	100.5



**Dimensions: Body Material: C37 (Brass), Stainless Steel**

**Conduit**

**Faston type**

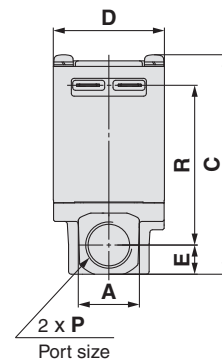
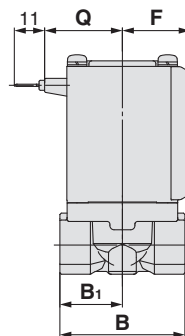
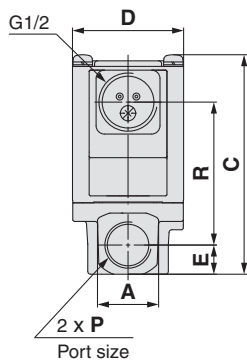
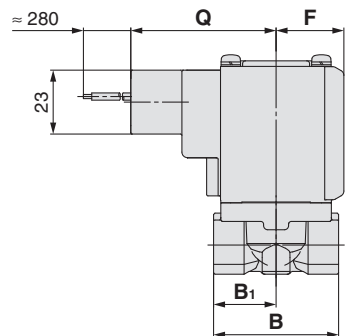
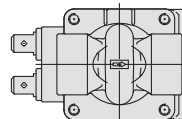
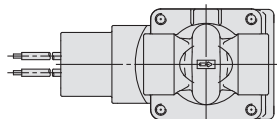

Size	Port size P	A	B	B <sub>1</sub>	C	D	E	F	(mm)			
									Electrical entry			
									Conduit		Faston type	
Q	R	Q	R									
1	1/8, 1/4	19	43	21	61	30	9.5	20	47.5	36	23	42
2	1/4, 3/8	22	45	22.5	74.5	35	10.5	22	50	47	25.5	53.5
3	1/4, 3/8	22	45	22.5	79	40	10.5	24.5	52.5	51.5	28	57.5
	1/2	29.5	50	25	85.5	40	14	24.5	52.5	55	28	61

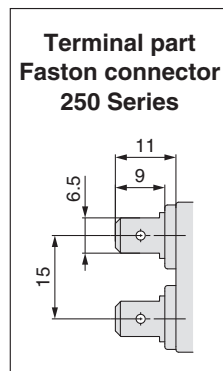

**Replacement Parts**

● **DIN Connector Part No.**

Without electrical option

**C183312G6GCU**

With electrical option (light)

**GDM2A-L**

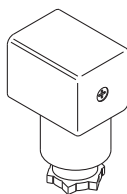

Electrical option  
L With light

Rated voltage

1	100 VAC, 110 VAC
2	200 VAC, 220 VAC 230 VAC, 240 VAC
5	24 VDC
6	12 VDC
15	48 VAC

● **Gasket for DIN Connector**

**VCW20-1-29-1**

● **Lead Wire Assembly for Faston Terminal (Set of 2 pcs.)**

**VX021S-1-16FB**

Specifications

For Air

For Medium Vacuum

For Water

For Oil

Construction

Dimensions

# Series VX21/22/23

## Glossary of Terms

### Pressure Terminology

#### 1. Maximum operating pressure differential

The maximum pressure differential (the difference between the inlet and outlet pressure) which is allowed for operation. When the outlet pressure is 0 MPa, this becomes the maximum operating pressure.

#### 2. Minimum operating pressure differential

The minimum pressure differential (the difference between the inlet pressure and outlet pressure) required to keep the main valve fully opened.

#### 3. Maximum system pressure

The maximum pressure that can be applied inside the pipelines (line pressure).

[The pressure differential in the solenoid valve portion must be less than the maximum operating pressure differential.]

#### 4. Withstand pressure

The pressure in which the valve must be withstood without a drop in performance after holding for one minute under prescribed (static) pressure and returning to the operating pressure range. [value under the prescribed conditions]

### Electrical Terminology

#### 1. Surge voltage

A high voltage which is momentarily generated by shutting off the power in the shut-off area.

#### 2. Enclosure

A degree of protection defined in the "JIS C 0920: Waterproof test of electric machinery/appliance and the degree of protection against the intrusion of solid foreign objects".

Verify the degree of protection for each product.



#### ● First Characteristics: Degrees of protection against solid foreign objects

0	Non-protected
1	Protected against solid foreign objects of 50 mmø and greater
2	Protected against solid foreign objects of 12 mmø and greater
3	Protected against solid foreign objects of 2.5 mmø and greater
4	Protected against solid foreign objects of 1.0 mmø and greater
5	Dust-protected
6	Dusttight

#### ● Second Characteristics: Degrees of protection against water

0	Non-protected	—
1	Protected against vertically falling water drops	Dripproof type 1
2	Protected against vertically falling water drops when enclosure tilted up to 15°	Dripproof type 2
3	Protected against rainfall when enclosure tilted up to 60°	Rainproof type
4	Protected against splashing water	Splashproof type
5	Protected against water jets	Low jetproof type
6	Protected against powerful water jets	Strong jetproof type
7	Protected against the effects of temporary immersion in water	Immersion type
8	Protected against the effects of continuous immersion in water	Submersible type

Example) IP65: Dusttight, Low jetproof type

"Low jetproof type" means that no water intrudes inside an equipment that could hinder from operating normally by means of applying water for 3 minutes in the prescribed manner. Take appropriate protection measures, since a device is not usable in an environment where a droplet of water is splashed constantly.

### Others

#### 1. Material

NBR: Nitrile rubber

FKM: Fluoro rubber – Trade names: Viton®, Dai-el®, etc.

#### 2. Oil-free treatment

The degreasing and washing of wetted parts

#### 3. Passage symbol

In the JIS symbol (≡ $\square$  $\square$  $\square$ ) IN and OUT are in a blocked condition ( $\perp$ ), but actually in the case of reverse pressure (OUT>IN), there is a limit to the blocking.

( $\Delta$ ) is used to indicate that blocking of reverse pressure is not possible.

### Faston Terminal

1. Faston™ is a trademark of Tyco Electronics Corp.

2. For electrical connection of the Faston terminal and molded coil, please use Tyco's "Amp/Faston connector/250 Series" or the equivalent.

# Solenoid Valve Flow-rate Characteristics 1

## (How to indicate flow-rate characteristics)

### 1. Indication of flow-rate characteristics

The flow-rate characteristics in equipment such as a solenoid valve, etc. are indicated in their specifications as shown in Table (1).

Table (1) Indication of Flow-rate Characteristics

Corresponding equipment	Indication by international standard	Other indications	Conformed standard
Pneumatic equipment	<b>C, b</b>	—	ISO 6358: 1989 JIS B 8390: 2000
	—	<b>S</b>	JIS B 8390: 2000 Equipment: JIS B 8373, 8374, 8375, 8379, 8381
	—	<b>Cv</b>	ANSI/(NFPA)T3.21.3: 1990
Process fluid control equipment	<b>Av</b>	—	IEC60534-2-3: 1997 JIS B 2005: 1995
	—	<b>Cv</b>	Equipment: JIS B 8471, 8472, 8473

### 2. Pneumatic equipment

#### 2.1 Indication according to the international standards

(1) Conformed standard

ISO 6358: 1989 : Pneumatic fluid power—Components using compressible fluids—  
Determination of flow-rate characteristics

JIS B 8390: 2000 : Pneumatic fluid power—Components using compressible fluids—  
How to test flow-rate characteristics

(2) Definition of flow-rate characteristics

The flow-rate characteristics are indicated as a result of a comparison between sonic conductance **C** and critical pressure ratio **b**.

Sonic conductance **C** : Value which divides the passing mass flow rate of an equipment in a choked flow condition by the product of the upstream absolute pressure and the density in a standard condition.

Critical pressure ratio **b** : Pressure ratio (downstream pressure/upstream pressure) which will turn to a choked flow when the value is smaller than this ratio.

Choked flow : The flow in which the upstream pressure is higher than the downstream pressure and where sonic speed in a certain part of an equipment is reached.  
Gaseous mass flow rate is in proportion to the upstream pressure and not dependent on the downstream pressure.

Subsonic flow : Flow greater than the critical pressure ratio

Standard condition : Air in a temperature state of 20°C, absolute pressure 0.1 MPa (= 100 kPa = 1 bar), relative humidity 65%.

It is stipulated by adding the "(ANR)" after the unit depicting air volume.  
(standard reference atmosphere)

Conformed standard: ISO 8778: 1990 Pneumatic fluid power—Standard reference atmosphere, JIS B 8393: 2000: Pneumatic fluid power—Standard reference atmosphere

(3) Formula for flow rate

Described by the practical units as following.

When  $\frac{P_2 + 0.1}{P_1 + 0.1} \leq b$ , choked flow

$$Q = 600 \times C (P_1 + 0.1) \sqrt{\frac{293}{273 + t}} \dots\dots\dots(1)$$

When  $\frac{P_2 + 0.1}{P_1 + 0.1} > b$ , subsonic flow

$$Q = 600 \times C (P_1 + 0.1) \sqrt{1 - \left[ \frac{P_2 + 0.1}{P_1 + 0.1} - b \right]^2} \sqrt{\frac{293}{273 + t}} \dots\dots\dots(2)$$

**Q** : Air flow rate [dm<sup>3</sup>/min (ANR)], dm<sup>3</sup> (Cubic decimetre) of SI unit are allowed to be described by ℓ (litre).  
1 dm<sup>3</sup> = 1 ℓ

# Solenoid Valve Flow-rate Characteristics 2

## (How to indicate flow-rate characteristics)

**C** : Sonic conductance [dm<sup>3</sup>/(s·bar)]

**b** : Critical pressure ratio [—]

**P<sub>1</sub>** : Upstream pressure [MPa]

**P<sub>2</sub>** : Downstream pressure [MPa]

**t** : Temperature [°C]

Note) Formula of subsonic flow is the elliptic analogous curve.

Flow-rate characteristics are shown in Graph (1) For details, please make use of SMC's "Energy Saving Program".

Example)

Obtain the air flow rate for **P<sub>1</sub>** = 0.4 [MPa], **P<sub>2</sub>** = 0.3 [MPa], **t** = 20 [°C] when a solenoid valve is performed in **C** = 2 [dm<sup>3</sup>/(s·bar)] and **b** = 0.3.

According to formula (1), the maximum flow rate =  $600 \times 2 \times (0.4 + 0.1) \times \sqrt{\frac{293}{273 + 20}} = 600$  [dm<sup>3</sup>/min (ANR)]

$$\text{Pressure ratio} = \frac{0.3 + 0.1}{0.4 + 0.1} = 0.8$$

Based on Graph (1), the flow rate ratio will be 0.7 when the pressure ratio is 0.8 and **b** = 0.3.  
Therefore, flow rate = Maximum flow rate x flow rate ratio = 600 x 0.7 = 420 [dm<sup>3</sup>/min (ANR)]

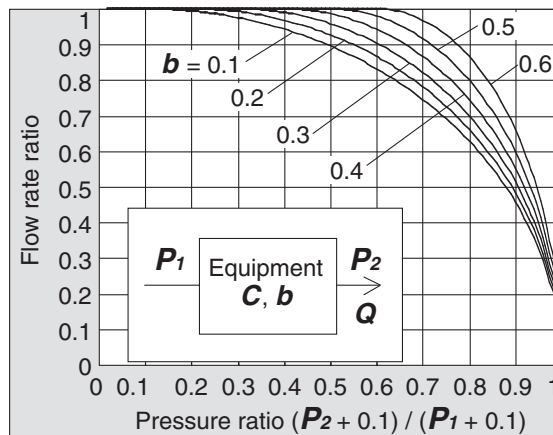

Graph (1) Flow-rate characteristics

#### (4) Test method

Attach a test equipment with the test circuit shown in Fig. (1) while maintaining the upstream pressure to a certain level which does not go below 0.3 MPa. Next, measure the maximum flow to be saturated in the first place, then measure this flow rate at 80%, 60%, 40%, 20% and the upstream and downstream pressure. And then, obtain the sonic conductance **C** from this maximum flow rate. Besides that, substitute each data of others for the subsonic flow formula to find **b**, then obtain the critical pressure ratio **b** from that average.

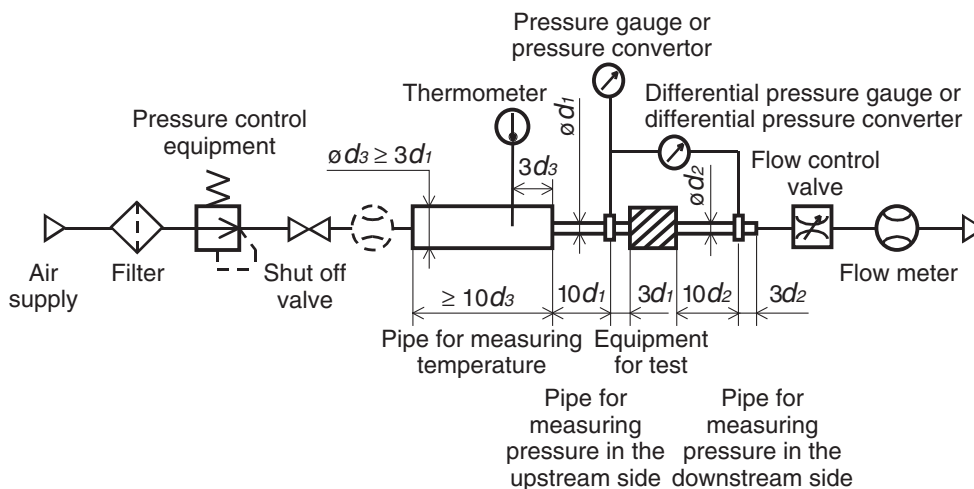

Fig. (1) Test circuit based on ISO 6358, JIS B 8390



**2.2 Effective area S**

(1) Conformed standard

**JIS B 8390: 2000: Pneumatic fluid power—Components using compressible fluids—  
How to test flow-rate characteristics**

**Equipment standards: JIS B 8373: 2 port solenoid valve for pneumatics**

**JIS B 8374: 3 port solenoid valve for pneumatics**

**JIS B 8375: 4 port, 5 port solenoid valve for pneumatics**

**JIS B 8379: Silencer for pneumatics**

**JIS B 8381: Fittings of flexible joint for pneumatics**

(2) Definition of flow-rate characteristics

Effective area **S**: The cross-sectional area having an ideal throttle without friction or without reduced flow. It is deduced from the calculation of the pressure changes inside an air tank when discharging the compressed air in a choked flow, from an equipment attached to the air tank. This is the same concept representing the “easy to run through” as sonic conductance **C**.

(3) Formula for flow rate

When  $\frac{P_2 + 0.1}{P_1 + 0.1} \leq 0.5$ , **choked flow**

$$Q = 120 \times S (P_1 + 0.1) \sqrt{\frac{293}{273 + t}} \dots\dots\dots(3)$$

When  $\frac{P_2 + 0.1}{P_1 + 0.1} > 0.5$ , **subsonic flow**

$$Q = 240 \times S \sqrt{(P_2 + 0.1) (P_1 - P_2)} \sqrt{\frac{293}{273 + t}} \dots\dots\dots(4)$$

Conversion with sonic conductance **C**:

$$S = 5.0 \times C \dots\dots\dots(5)$$

**Q** : Air flow rate [dm<sup>3</sup>/min(ANR)], dm<sup>3</sup> (cubic decimetre) of SI unit are allowed to be described by **ℓ** (litre).  
1 dm<sup>3</sup> = 1 ℓ

**S** : Effective area [mm<sup>2</sup>]

**P<sub>1</sub>** : Upstream pressure [MPa]

**P<sub>2</sub>** : Downstream pressure [MPa]

**t** : Temperature [°C]

Note) Formula for subsonic flow (4) is only applicable when the critical pressure ratio **b** is unknown for equipment. In the formula (2) by the sonic conductance **C**, it is the same formula as when **b** = 0.5.

(4) Test method

Attach a test equipment with the test circuit shown in Fig. (2) in order to discharge air into the atmosphere until the pressure inside the air tank goes down to 0.25 MPa (0.2 MPa) from an air tank filled with the compressed air at a certain pressure level (0.5 MPa) which does not go below 0.6 MPa. At this time, measure the discharging time and the residual pressure inside the air tank which had been left until it turned to be the normal values to determine the effective area **S**, using the following formula. The volume of an air tank should be selected within the specified range by corresponding to the effective area of an equipment for test. In the case of JIS B 8373, 8374, 8375, 8379, 8381, the pressure values are in parentheses and the coefficient of the formula is 12.9.

$$S = 12.1 \frac{V}{t} \log_{10} \left( \frac{P_s + 0.1}{P + 0.1} \right) \sqrt{\frac{293}{T}} \dots\dots\dots(6)$$

**S** : Effective area [mm<sup>2</sup>]

**V** : Air tank capacity [dm<sup>3</sup>]

**t** : Discharging time [s]

**P<sub>s</sub>**: Pressure inside air tank before discharging [MPa]

**P** : Residual pressure inside air tank after discharging [MPa]

**T** : Temperature inside air tank before discharging [K]

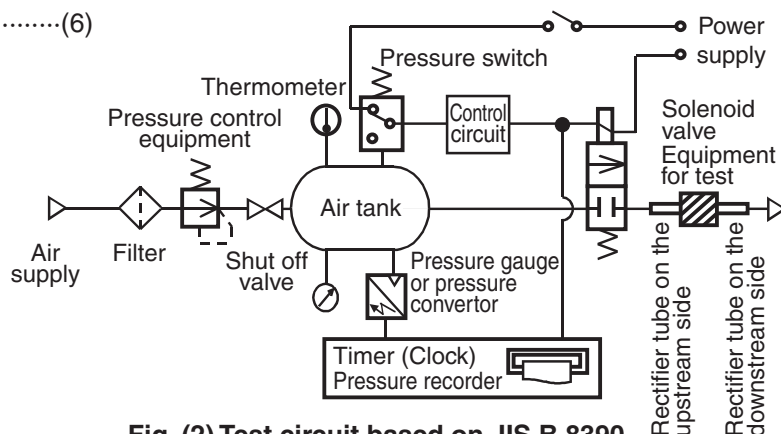

**Fig. (2) Test circuit based on JIS B 8390**

# Solenoid Valve Flow-rate Characteristics 3

## (How to indicate flow-rate characteristics)

### 2.3 Flow coefficient *Cv* factor

The United States Standard ANSI/(NFPA)T3.21.3: 1990: Pneumatic fluid power—Flow rating test procedure and reporting method for fixed orifice components

Defines the flow coefficient, *Cv* factor by the following formula which is based on the test conducted by the test circuit analogous to ISO 6358.

$$Cv = \frac{Q}{114.5 \sqrt{\frac{\Delta P (P_2 + Pa)}{T_1}}} \dots\dots\dots(7)$$

$\Delta P$  : Pressure drop between the static pressure tapping ports [bar]

$P_1$  : Pressure of the upstream tapping port [bar gauge]

$P_2$  : Pressure of the downstream tapping port [bar gauge]:  $P_2 = P_1 - \Delta P$

$Q$  : Flow rate [dm<sup>3</sup>/s standard condition]

$Pa$  : Atmospheric pressure [bar absolute]

$T_1$  : Upstream absolute temperature [K]

Test conditions are  $P_1 + Pa = 6.5 \pm 0.2$  bar absolute,  $T_1 = 297 \pm 5$  K,  $0.07 \text{ bar} \leq \Delta P \leq 0.14$  bar.

This is the same concept as effective area *A* which ISO 6358 stipulates as being applicable only when the pressure drop is smaller than the upstream pressure and the compression of air does not become a problem.

### 3. Process fluid control equipment

(1) Conformed standard

IEC60534-2-3: 1997: Industrial process control valves. Part 2: Flow capacity, Section Three-Test procedures

JIS B 2005: 1995: How to test flow coefficient of a valve

Equipment standards: JIS B 8471: Solenoid valve for water

JIS B 8472: Solenoid valve for steam

JIS B 8473: Solenoid valve for fuel oil

(2) Definition of flow-rate characteristics

*Av* factor: Value of the clean water flow rate represented by m<sup>3</sup>/s which runs through a valve (equipment for test) when the pressure differential is 1 Pa. It is calculated using the following formula.

$$Av = Q \sqrt{\frac{\rho}{\Delta P}} \dots\dots\dots(8)$$

*Av* : Flow coefficient [m<sup>2</sup>]

$Q$  : Flow rate [m<sup>3</sup>/s]

$\Delta P$  : Pressure differential [Pa]

$\rho$  : Fluid density [kg/m<sup>3</sup>]

(3) Formula for flow rate

Described by the practical units. Also, the flow-rate characteristics are shown in Graph (2).

In the case of liquid:

$$Q = 1.9 \times 10^6 Av \sqrt{\frac{\Delta P}{G}} \dots\dots\dots(9)$$

$Q$  : Flow rate [ℓ/min]

*Av* : Flow coefficient [m<sup>2</sup>]

$\Delta P$  : Pressure differential [MPa]

$G$  : Specific gravity [water = 1]

In the case of saturated steam:

$$Q = 8.3 \times 10^6 Av \sqrt{\Delta P (P_2 + 0.1)} \dots\dots\dots(10)$$

$Q$  : Flow rate [kg/h]

*Av* : Flow coefficient [m<sup>2</sup>]

$\Delta P$  : Pressure differential [MPa]

$P_1$  : Upstream pressure [MPa]:  $\Delta P = P_1 - P_2$

$P_2$  : Downstream pressure [MPa]

Conversion of flow coefficient:

$$Av = 28 \times 10^{-6} Kv = 24 \times 10^{-6} Cv \dots\dots\dots(11)$$

Here,

**Kv** factor : Value of the clean water flow rate represented by m<sup>3</sup>/h which runs through a valve at 5 to 40°C, when the pressure differential is 1 bar.

**Cv** factor (Reference values): Value of the clean water flow rate represented by US gal/min which runs through a valve at 60°F, when the pressure differential is 1 lbf/in<sup>2</sup> (psi).

Value is different from **Kv** and **Cv** factors for pneumatic purpose due to different test method.

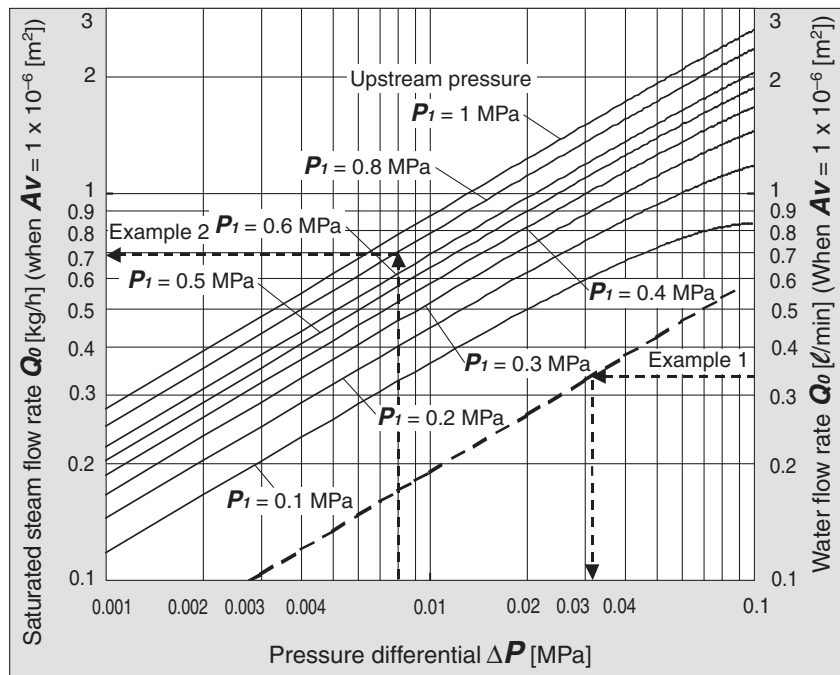

**Graph (2) Flow-rate characteristics**

Example 1)

Obtain the pressure differential when water 15 [l/min] runs through a solenoid valve with an **Av** = 45 x 10<sup>-6</sup> [m<sup>2</sup>]. Since **Q<sub>0</sub>** = 15/45 = 0.33 [l/min], according to Graph (2), if reading **ΔP** when **Q<sub>0</sub>** is 0.33, it will be 0.031 [MPa].

Example 2)

Obtain the saturated steam flow rate when **P<sub>1</sub>** = 0.8 [MPa], **ΔP** = 0.008 [MPa] with a solenoid valve with an **Av** = 1.5 x 10<sup>-6</sup> [m<sup>2</sup>].

According to Graph (2), if reading **Q<sub>0</sub>** when **P<sub>1</sub>** is 0.8 and **ΔP** is 0.008, it is 0.7 [kg/h]. Therefore, the flow rate **Q** = 0.7 x 1.5 = 1.05 [kg/h].

(4) Test method

Attach a test equipment with the test circuit shown in Fig. (3). Next, pour water at 5 to 40°C, then measure the flow rate with a pressure differential of 0.075 MPa. However, the pressure differential needs to be set with a large enough difference so that the Reynolds number does not go below a range of 4 x 10<sup>4</sup>.

By substituting the measurement results for formula (8) to figure out **Av**.

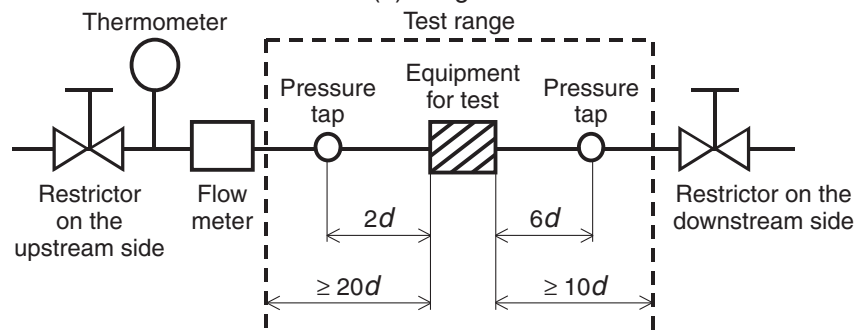

**Fig. (3) Test circuit based on IEC60534-2-3, JIS B 2005**

# Series VX21/22/23

# Flow-rate Characteristics

Note) Use this graph as a guide. In the case of obtaining an accurate flow rate, refer to pages 17 through to 21.

## For Air

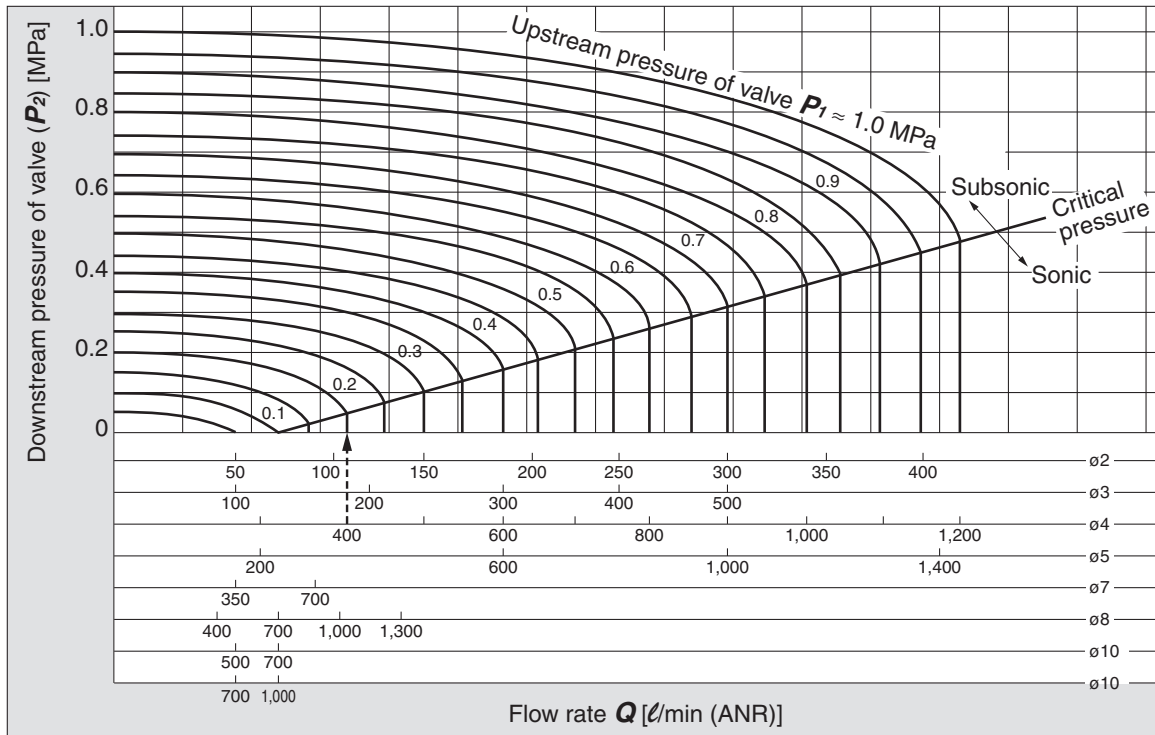

### How to read the graph

The sonic range pressure to generate a flow rate of 400 ℓ/min (ANR) is  $P_1 \approx 0.2$  MPa for a  $\phi 4$  orifice and  $P_1 \approx 0.58$  MPa for a  $\phi 3$  orifice.

## For Water

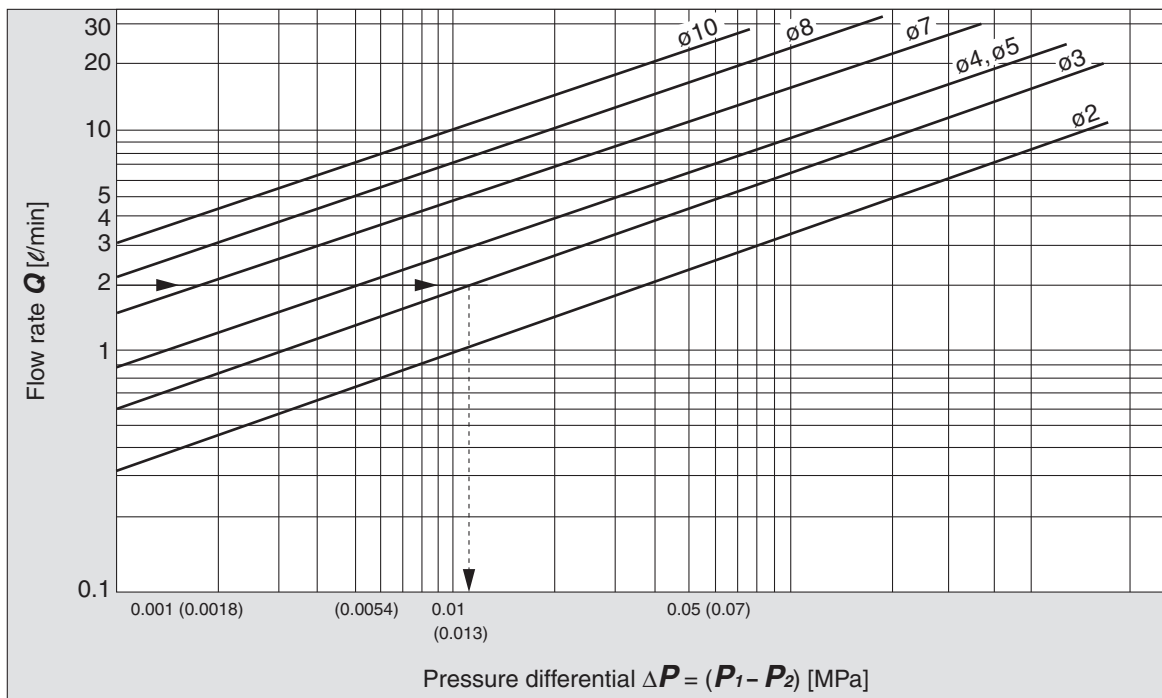

### How to read the graph

When a water flow of 2 ℓ/min is generated,  $\Delta P \approx 0.013$  MPa for a valve with  $\phi 3$  orifice.

## Specific Product Precautions 1



Be sure to read before handling.

Refer to back cover for Safety Instructions, “Handling Precautions for SMC Products” (M-E03-3) and the Operation Manual for 2 Port Solenoid Valves for Fluid Control Precautions. Please download it via our website. <http://www.smc.eu>

## Design

**Warning**

- 1. Cannot be used as an emergency shutoff valve, etc.**  
The valves presented in this catalogue are not designed for safety applications such as an emergency shutoff valve. If the valves are used in this type of system, other reliable safety assurance measures should also be adopted.
- 2. Extended periods of continuous energisation**  
The solenoid coil will generate heat when continuously energised. Avoid using in a tightly shut container. Install it in a well-ventilated area. Furthermore, do not touch it while it is being energised or right after it is energised.
- 3. Liquid rings**  
In cases with a flowing liquid, provide a bypass valve in the system to prevent the liquid from entering the liquid seal circuit.
- 4. Actuator drive**  
When an actuator, such as a cylinder, is to be driven using a valve, take appropriate measures to prevent potential danger caused by actuator operation.
- 5. Pressure (including vacuum) holding**  
It is not usable for an application such as holding the pressure (including vacuum) inside of a pressure vessel because air leakage is entailed in a valve.
- 6. When the conduit type is used as equivalent to an IP65 enclosure, install a wiring conduit, etc.**
- 7. When an impact, such as water hammer, etc., caused by the rapid pressure fluctuation is applied, the solenoid valve may be damaged. Give an attention to it.**

## Selection

**Warning**

- 1. Fluid**
  - 1) Type of fluid**  
Before using a fluid, check whether it is compatible with the materials of each model by referring to the fluids listed in this catalogue. Use a fluid with a kinematic viscosity of 50 mm<sup>2</sup>/s or less. If there is something you do not know, please contact SMC.
  - 2) Flammable oil, Gas**  
Confirm the specification for leakage in the interior and/or exterior area.
  - 3) Corrosive gas**  
Cannot be used since it will lead to cracks by stress corrosion or result in other incidents.
  - 4) Depending on water quality, a brass body can cause corrosion and internal leakage may occur. If such abnormalities occur, exchange the product for a stainless steel body.**
  - 5) Use an oil-free specification when any oily particle must not enter the passage.**
  - 6) Applicable fluid on the list may not be used depending on the operating condition. Give adequate confirmation, and then determine a model, just because the compatibility list shows the general case.**

## Selection

**Warning**

- 2. Fluid quality**  
The use of a fluid that contains foreign objects can cause problems such as malfunction and seal failure by promoting wear of the valve seat and armature, and by sticking to the sliding parts of the armature, etc. Install a suitable filter (strainer) immediately upstream from the valve. As a general rule, use 80 to 100 mesh.  
When using tap water, since substances such as calcium and magnesium which generate hard scale and sludge are included and can cause the valve to malfunction, install water softening equipment and a filter (strainer) right before the valve to remove these substances.
- 3. Air quality**
  - 1) Use clean air.**  
Do not use compressed air that contains chemicals, synthetic oils including organic solvents, salt or corrosive gases, etc., as it can cause damage or malfunction.
  - 2) Install an air filter.**  
Install an air filter close to the valve on the upstream side. A filtration degree of 5 µm or less should be selected.
  - 3) Install an aftercooler or air dryer, etc.**  
Compressed air that contains excessive drainage may cause malfunction of valves and other pneumatic equipment. To prevent this, install an aftercooler or air dryer, etc.
  - 4) If excessive carbon powder is generated, eliminate it by installing a mist separator on the upstream side of valves.**  
If excessive carbon powder is generated by the compressor, it may adhere to the inside of the valves and cause a malfunction.
- 4. Ambient environment**  
Use within the operable ambient temperature range. Check the compatibility between the product's composition materials and the ambient atmosphere. Be certain that the fluid used does not touch the external surface of the product.
- 5. Countermeasures against static electricity**  
Take measures to prevent static electricity since some fluids can cause static electricity.
- 6. Low temperature operation**
  - 1) The valve can be used in an ambient temperature of between -10 to -20°C. However, take measures to prevent freezing or solidification of impurities, etc.**
  - 2) When using valves for water application in cold climates, take appropriate countermeasures to prevent the water from freezing in tubing after cutting the water supply from the pump, by draining the water, etc. When warming by a heater, etc., be careful not to expose the coil portion to a heater. Installation of a dryer, heat retaining of the body is recommended to prevent a freezing condition in which the dew point temperature is high and the ambient temperature is low, and the high flow runs.**



# Series VX21/22/23 Specific Product Precautions 2

Be sure to read before handling.

Refer to back cover for Safety Instructions, "Handling Precautions for SMC Products" (M-E03-3) and the Operation Manual for 2 Port Solenoid Valves for Fluid Control Precautions. Please download it via our website. <http://www.smc.eu>

## Selection

### Warning

#### 7. Fluid quality

##### • Water

The use of a fluid that contains foreign objects can cause problems such as malfunction and seal failure by promoting wear of the valve seat and armature, and by sticking to the sliding parts of the armature, etc. Install a suitable filter (strainer) immediately upstream from the valve. As a general rule, use 50 to 100 mesh.

When using tap water, since substances such as calcium and magnesium which generate hard scale and sludge are included and can cause the valve to malfunction, install water softening equipment and a filter (strainer) right before the valve to remove these substances.

##### • Air

Use ordinary compressed air where a filter of 5 µm or less is provided on the inlet side piping. (Except dry air)

##### • Oil

Generally, FKM is used as seal material, as it is resistant to oil. The resistance of the sealing material may deteriorate depending on the type of oil, manufacturer, or additives. Check the resistance before using.

### Caution

#### 1. Leakage voltage

Particularly when using a resistor in parallel with a switching element and using a C-R element (surge voltage suppressor) to protect the switching element, take note that leakage current will flow through the resistor, C-R element, etc., creating a possible danger that the valve may not turn off.

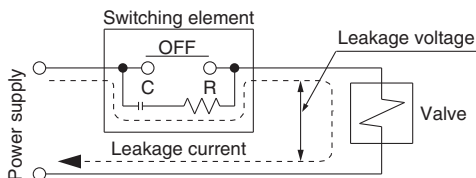

AC/Class B built-in full-wave rectifier coil: 10% or less of rated voltage

DC coil: 2% or less of rated voltage

#### 2. Selecting model

Material depends on fluid. Select optimal models for the fluid.

#### 3. When the fluid is oil.

The kinematic viscosity must not exceed 50 mm<sup>2</sup>/s.

## Mounting

### Warning

#### 1. If air leakage increases or equipment does not operate properly, stop operation.

After mounting is completed, confirm that it has been done correctly by performing a suitable function test.

#### 2. Do not apply external force to the coil section.

When tightening is performed, apply a wrench or other tool to the outside of the piping connection parts.

## Mounting

### Warning

#### 3. Mount a valve with its coil position upwards, not downwards.

When mounting a valve with its coil positioned downwards, foreign objects in the fluid will adhere to the iron core leading to a malfunction. Especially for strict leakage control, such as with vacuum applications and non-leak specifications, the coil must be positioned upwards.

#### 4. Do not warm the coil assembly with a heat insulator, etc.

Use tape, heaters, etc., for freeze prevention on the piping and body only. They can cause the coil to burn out.

#### 5. Secure with brackets, except in the case of steel piping and copper fittings.

#### 6. Avoid sources of vibration, or adjust the arm from the body to the minimum length so that resonance will not occur.

#### 7. Painting and coating

Warnings or specifications printed or labelled on the product should not be erased, removed or covered up.

## Piping

### Warning

#### 1. During use, deterioration of the tube or damage to the fittings could cause tubes to come loose from their fittings and thrash about.

To prevent uncontrolled tube movement, install protective covers or fasten tubes securely in place.

#### 2. For piping the tube, fix the product securely using the mounting holes so that the product is not in the air.

### Caution

#### 1. Preparation before piping

Before piping is connected, it should be thoroughly blown out with air (flushing) or washed to remove chips, cutting oil and other debris from inside the pipe.

Install piping so that it does not apply pulling, pressing, bending or other forces on the valve body.

#### 2. Avoid connecting ground lines to piping, as this may cause electric corrosion of the system.

#### 3. Tighten threads with the proper tightening torque.

When attaching fittings to valves, tighten with the proper tightening torque shown below.

#### Tightening Torque for Piping

Connection thread	Proper tightening torque (N·m)
Rc1/8	7 to 9
Rc1/4	12 to 14
Rc3/8	22 to 24
Rc1/2	28 to 30

#### 4. Connection of piping to products

When connecting piping to a product, refer to its operation manual to avoid mistakes regarding the supply port, etc.

#### 5. In applications such as vacuum and non-leak specifications, use caution specifically against the contamination of foreign objects or airtightness of the fittings.





# Series VX21/22/23 Specific Product Precautions 3

Be sure to read before handling.

Refer to back cover for Safety Instructions, "Handling Precautions for SMC Products" (M-E03-3) and the Operation Manual for 2 Port Solenoid Valves for Fluid Control Precautions. Please download it via our website. <http://www.smc.eu>

## Recommended Piping Conditions

1. When connecting tubes using one-touch fittings, provide some spare tube length shown in Fig. 1, recommended piping configuration.

Also, do not apply external force to the fittings when binding tubes with bands, etc. (see Fig. 2.)

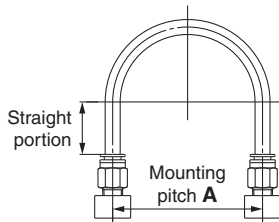

Fig. 1 Recommended piping configuration

Unit: mm

Tube size	Mounting pitch A			Straight portion length
	Nylon tube	Soft nylon tube	Polyurethane tube	
ø1/8"	44 or more	29 or more	25 or more	16 or more
ø6	84 or more	39 or more	39 or more	30 or more
ø1/4"	89 or more	56 or more	57 or more	32 or more
ø8	112 or more	58 or more	52 or more	40 or more
ø10	140 or more	70 or more	69 or more	50 or more
ø12	168 or more	82 or more	88 or more	60 or more

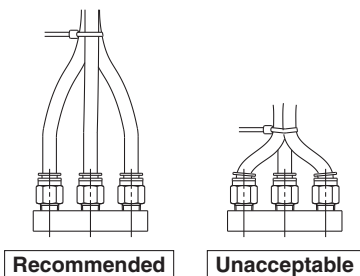

Fig. 2 Binding tubes with bands

## Wiring

### ⚠ Caution

1. As a rule, use electrical wire with a cross sectional area of 0.5 to 1.25 mm<sup>2</sup> for wiring. Furthermore, do not allow excessive force to be applied to the lines.
2. Use electrical circuits which do not generate chattering in their contacts.
3. Use voltage which is within ±10% of the rated voltage. In cases with a DC power supply where importance is placed on responsiveness, stay within ±5% of the rated value. The voltage drop is the value in the lead wire section connecting the coil.
4. When a surge from the solenoid affects the electrical circuitry, install a surge voltage suppressor, etc., in parallel with the solenoid. Or, adopt an option that comes with the surge voltage protection circuit. (However, a surge voltage occurs even if the surge voltage protection circuit is used. For details, please consult with SMC.)

## Operating Environment

### ⚠ Warning

1. Do not use in an atmosphere having corrosive gases, chemicals, sea water, water, water steam, or where there is direct contact with any of these.
2. Do not use in explosive atmospheres.
3. Do not use in locations subject to vibration or impact.
4. Do not use in locations where radiated heat will be received from nearby heat sources.
5. Employ suitable protective measures in locations where there is contact with water droplets, oil or welding spatter, etc.

## Maintenance

### ⚠ Warning

#### 1. Removing the product

The valve will reach a high temperature when used with high temperature fluids. Confirm that the valve temperature has dropped sufficiently before performing work. If touched inadvertently, there is a danger of being burned.

- 1) Shut off the fluid supply and release the fluid pressure in the system.
- 2) Shut off the power supply.
- 3) Remove the product.

#### 2. Low frequency operation

Switch valves at least once every 30 days to prevent malfunction. Also, in order to use it under the optimum state, conduct a regular inspection once a half year.

### ⚠ Caution

#### 1. Filters and strainers

- 1) Be careful regarding clogging of filters and strainers.
- 2) Replace filter elements after one year of use, or earlier if the pressure drop reaches 0.1 MPa.
- 3) Clean strainers when the pressure drop reaches 0.1 MPa.

#### 2. Lubrication

When using after lubricating, never forget to lubricate continuously.

#### 3. Storage

In case of long term storage after use with heated water, thoroughly remove all moisture to prevent rust and deterioration of rubber materials, etc.

#### 4. Exhaust the drainage from an air filter periodically.

## Operating Precautions

### ⚠ Warning

1. If there is a possibility of reverse pressure being applied to the valve, take countermeasures such as mounting a check valve on the downstream side of the valve.
2. When problems are caused by a water hammer, install water hammer relief equipment (accumulator, etc.), or use an SMC water hammer relief valve (Series VXR). For details, please consult with SMC.



# Series VX21/22/23 Specific Product Precautions 4

Be sure to read before handling.

Refer to back cover for Safety Instructions, "Handling Precautions for SMC Products" (M-E03-3) and the Operation Manual for 2 Port Solenoid Valves for Fluid Control Precautions. Please download it via our website. <http://www.smc.eu>

## Electrical Connections

### ⚠ Caution

#### ■ Grommet

Class B coil: AWG20 Outside insulator diameter of 2.5 mm

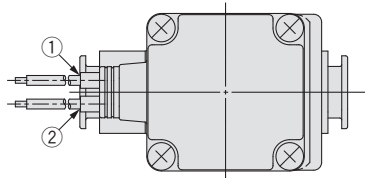

Rated voltage	Lead wire colour	
	①	②
DC	Black	Red
100 VAC	Blue	Blue
200 VAC	Red	Red
Other AC	Grey	Grey

\* There is no polarity.

#### ■ DIN terminal

Since internal connections are shown below for the DIN terminal, make connections to the power supply accordingly.

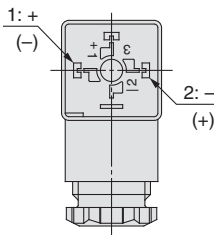

Terminal no.	1	2
DIN terminal	+ (-)	- (+)

\* There is no polarity.

- Use a heavy-duty cord with an outside cable diameter of  $\phi 6$  to 12 mm.
- Use the tightening torques below for each section.

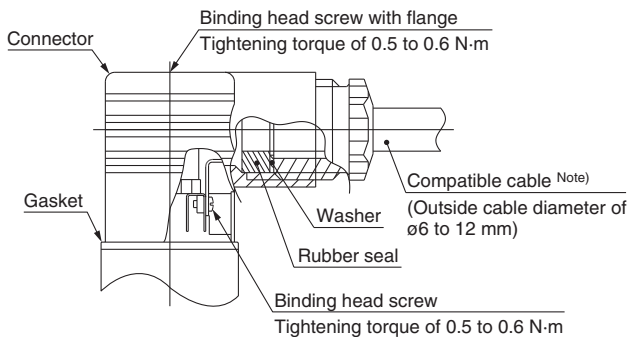

Note) For an outside cable diameter of  $\phi 9$  to 12 mm, remove the internal parts of the rubber seal before using.

#### ■ Conduit terminal

In the case of the conduit terminal, make connections according to the marks shown below.

- Use the tightening torques below for each section.
- Properly seal the terminal connection (G1/2) with the special wiring conduit, etc.

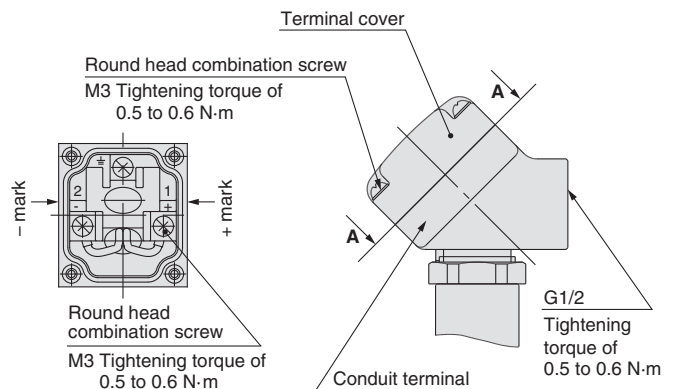

#### View A-A

(Internal connection diagram)

#### ■ Conduit

When used as an IP65 equivalent, use seal to install the wiring conduit. Also, use the tightening torque below for the conduit.

Class B coil: AWG20 Outside insulator diameter of 2.5 mm

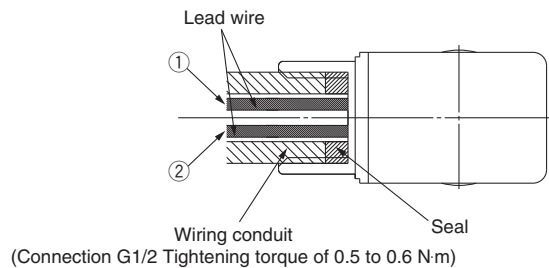

Rated voltage	Lead wire colour	
	①	②
DC	Black	Red
100 VAC	Blue	Blue
200 VAC	Red	Red
Other AC	Grey	Grey

\* There is no polarity.

(There is polarity for power-saving type.)

Description	Part no.
Seal	VCW20-15-6

Note) Please order separately.



# Series VX21/22/23 Specific Product Precautions 5

Be sure to read before handling.

Refer to back cover for Safety Instructions, "Handling Precautions for SMC Products" (M-E03-3) and the Operation Manual for 2 Port Solenoid Valves for Fluid Control Precautions. Please download it via our website. <http://www.smc.eu>

## Electrical Circuits

### ⚠ Caution

#### [DC circuit]

Grommet, Faston terminal

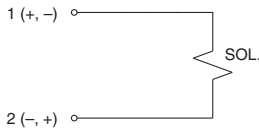

Without electrical option

Grommet, DIN terminal,  
Conduit terminal, Conduit

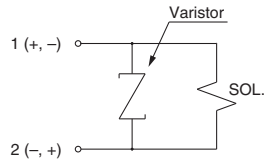

With surge voltage suppressor

DIN terminal, Conduit terminal

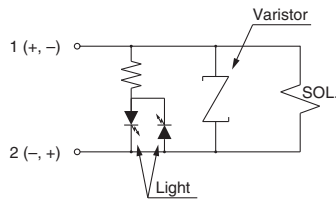

With light/surge voltage suppressor

#### [AC circuit]

\* For AC (Class B), the standard product is equipped with surge voltage suppressor.

Grommet, DIN terminal,  
Conduit terminal, Conduit

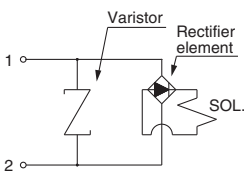

Without electrical option

DIN terminal, Conduit terminal

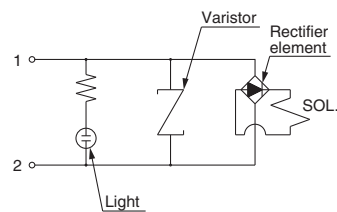

With light

## One-touch Fitting

### ⚠ Caution

For information on handling one-touch fittings and appropriate tubing, refer to page 25 and the KQ2 series one-touch fittings.

The KQ2 series information can be downloaded from the following SMC website, <http://www.smc.eu>





## Safety Instructions

These safety instructions are intended to prevent hazardous situations and/or equipment damage. These instructions indicate the level of potential hazard with the labels of “**Caution**,” “**Warning**” or “**Danger**.” They are all important notes for safety and must be followed in addition to International Standards (ISO/IEC)\*1), and other safety regulations.



### Caution:

**Caution** indicates a hazard with a low level of risk which, if not avoided, could result in minor or moderate injury.



### Warning:

**Warning** indicates a hazard with a medium level of risk which, if not avoided, could result in death or serious injury.



### Danger:

**Danger** indicates a hazard with a high level of risk which, if not avoided, will result in death or serious injury.

- \*1) ISO 4414: Pneumatic fluid power – General rules relating to systems.  
ISO 4413: Hydraulic fluid power – General rules relating to systems.  
IEC 60204-1: Safety of machinery – Electrical equipment of machines.  
(Part 1: General requirements)  
ISO 10218-1: Manipulating industrial robots - Safety.  
etc.

## Warning

### 1. The compatibility of the product is the responsibility of the person who designs the equipment or decides its specifications.

Since the product specified here is used under various operating conditions, its compatibility with specific equipment must be decided by the person who designs the equipment or decides its specifications based on necessary analysis and test results. The expected performance and safety assurance of the equipment will be the responsibility of the person who has determined its compatibility with the product. This person should also continuously review all specifications of the product referring to its latest catalogue information, with a view to giving due consideration to any possibility of equipment failure when configuring the equipment.

### 2. Only personnel with appropriate training should operate machinery and equipment.

The product specified here may become unsafe if handled incorrectly. The assembly, operation and maintenance of machines or equipment including our products must be performed by an operator who is appropriately trained and experienced.

### 3. Do not service or attempt to remove product and machinery/equipment until safety is confirmed.

- The inspection and maintenance of machinery/equipment should only be performed after measures to prevent falling or runaway of the driven objects have been confirmed.
- When the product is to be removed, confirm that the safety measures as mentioned above are implemented and the power from any appropriate source is cut, and read and understand the specific product precautions of all relevant products carefully.
- Before machinery/equipment is restarted, take measures to prevent unexpected operation and malfunction.

### 4. Contact SMC beforehand and take special consideration of safety measures if the product is to be used in any of the following conditions.

- Conditions and environments outside of the given specifications, or use outdoors or in a place exposed to direct sunlight.
- Installation on equipment in conjunction with atomic energy, railways, air navigation, space, shipping, vehicles, military, medical treatment, combustion and recreation, or equipment in contact with food and beverages, emergency stop circuits, clutch and brake circuits in press applications, safety equipment or other applications unsuitable for the standard specifications described in the product catalogue.
- An application which could have negative effects on people, property, or animals requiring special safety analysis.
- Use in an interlock circuit, which requires the provision of double interlock for possible failure by using a mechanical protective function, and periodical checks to confirm proper operation.

## Caution

### 1. The product is provided for use in manufacturing industries.

The product herein described is basically provided for peaceful use in manufacturing industries.

If considering using the product in other industries, consult SMC beforehand and exchange specifications or a contract if necessary.

If anything is unclear, contact your nearest sales branch.

## Limited warranty and Disclaimer/ Compliance Requirements

The product used is subject to the following “Limited warranty and Disclaimer” and “Compliance Requirements”.

Read and accept them before using the product.

### Limited warranty and Disclaimer

#### 1. The warranty period of the product is 1 year in service or 1.5 years after the product is delivered.\*2)

Also, the product may have specified durability, running distance or replacement parts. Please consult your nearest sales branch.

#### 2. For any failure or damage reported within the warranty period which is clearly our responsibility, a replacement product or necessary parts will be provided.

This limited warranty applies only to our product independently, and not to any other damage incurred due to the failure of the product.

#### 3. Prior to using SMC products, please read and understand the warranty terms and disclaimers noted in the specified catalogue for the particular products.

\*2) Vacuum pads are excluded from this 1 year warranty.

A vacuum pad is a consumable part, so it is warranted for a year after it is delivered.

Also, even within the warranty period, the wear of a product due to the use of the vacuum pad or failure due to the deterioration of rubber material are not covered by the limited warranty.

### Compliance Requirements

#### 1. The use of SMC products with production equipment for the manufacture of weapons of mass destruction (WMD) or any other weapon is strictly prohibited.

#### 2. The exports of SMC products or technology from one country to another are governed by the relevant security laws and regulations of the countries involved in the transaction. Prior to the shipment of a SMC product to another country, assure that all local rules governing that export are known and followed.

## Safety Instructions

Be sure to read “Handling Precautions for SMC Products” (M-E03-3) before using.

### SMC Corporation (Europe)

Austria	+43 (0)2262622800	www.smc.at	office@smc.at	Lithuania	+370 5 2308118	www.smclt.lt	info@smclt.lt
Belgium	+32 (0)33551464	www.smc-pneumatics.be	info@smc-pneumatics.be	Netherlands	+31 (0)205318888	www.smc-pneumatics.nl	info@smc-pneumatics.nl
Bulgaria	+359 (0)2807670	www.smc.bg	office@smc.bg	Norway	+47 67129020	www.smc-norge.no	post@smc-norge.no
Croatia	+385 (0)13707288	www.smc.hr	office@smc.hr	Poland	+48 (0)222119616	www.smc.pl	office@smc.pl
Czech Republic	+420 541424611	www.smc.cz	office@smc.cz	Portugal	+351 226166570	www.smc.eu	postpt@smc.smces.es
Denmark	+45 70252900	www.smcdk.com	smc@smcdk.com	Romania	+40 213205111	www.smcromania.ro	smcromania@smcromania.ro
Estonia	+372 6510370	www.smc-pneumatics.ee	smc@smc-pneumatics.ee	Russia	+7 8127185445	www.smc-pneumatik.ru	info@smc-pneumatik.ru
Finland	+358 207513513	www.smc.fi	smcfi@smc.fi	Slovakia	+421 (0)413213212	www.smc.sk	office@smc.sk
France	+33 (0)164761000	www.smc-france.fr	promotion@smc-france.fr	Slovenia	+386 (0)73885412	www.smc.si	office@smc.si
Germany	+49 (0)61034020	www.smc-pneumatik.de	info@smc-pneumatik.de	Spain	+34 945184100	www.smc.eu	post@smc.smces.es
Greece	+30 210 2717265	www.smchellas.gr	sales@smchellas.gr	Sweden	+46 (0)86031200	www.smc.nu	post@smc.nu
Hungary	+36 23511390	www.smc.hu	office@smc.hu	Switzerland	+41 (0)523963131	www.smc.ch	info@smc.ch
Ireland	+353 (0)14039000	www.smc-pneumatics.ie	sales@smc-pneumatics.ie	Turkey	+90 212 489 0 440	www.smc-pnomatik.com.tr	info@smc-pnomatik.com.tr
Italy	+39 0292711	www.smcitalia.it	mailbox@smcitalia.it	UK	+44 (0)845 121 5122	www.smc-pneumatics.co.uk	sales@smc-pneumatics.co.uk
Latvia	+371 67817700	www.smclv.lv	info@smclv.lv				