

PHYSICAL DIMENSIONS:

A	3.20 [.126]	+ 0.20 [.008]
B	1.60 [.063]	+ 0.20 [.008]
C	1.10 [.043]	+ 0.20 [.008]
D	0.51 [.020]	+ 0.25 [.010]

LI1206H151R-10

UNCONTROLLED DOCUMENT

ELECTRICAL CHARACTERISTICS:

Z @ 100MHz (Ω)	DCR (Ω)	Rated Current
Nominal	150	
Minimum	113	
Maximum	188	0.15
		800 mA

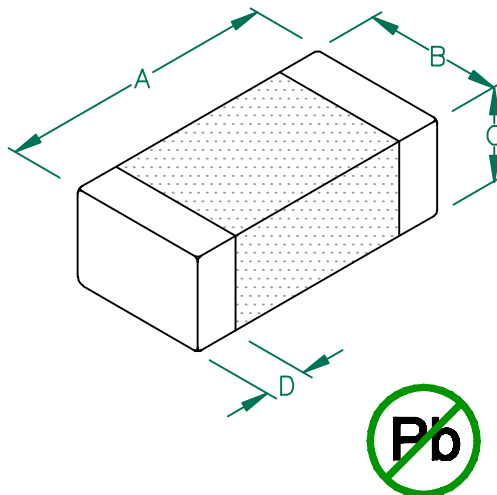

NOTES: UNLESS OTHERWISE SPECIFIED

1. TAPED AND REELED per CURRENT EIA SPECIFICATIONS 7" REELS, 3000 PCS/REEL.
2. TERMINATION FINISH IS 100% TIN.
3. COMPONENTS SHOULD BE ADEQUATELY PREHEATED BEFORE SOLDERING.

Z vs FREQUENCY
IMPEDANCE UNDER DC BIAS

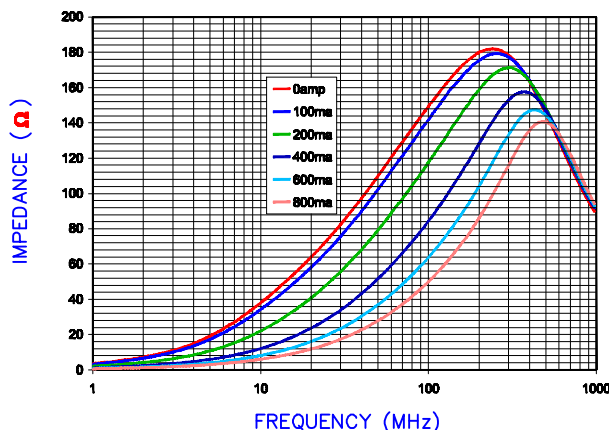

LAND PATTERNS FOR REFLOW SOLDERING

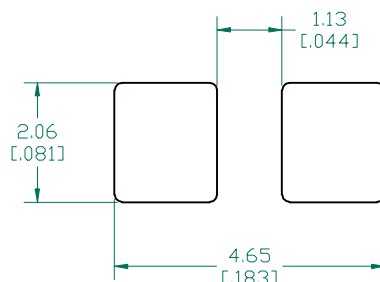

(For wave soldering, add 0.762 (.030) to this dimension)

RECOMMENDED SOLDERING CONDITIONS

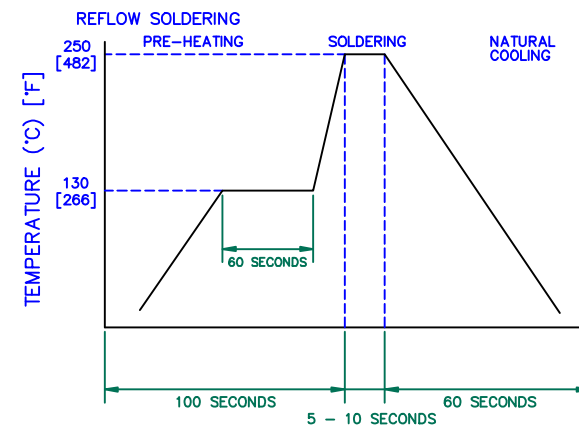

|Z|, R, AND X vs. FREQUENCY

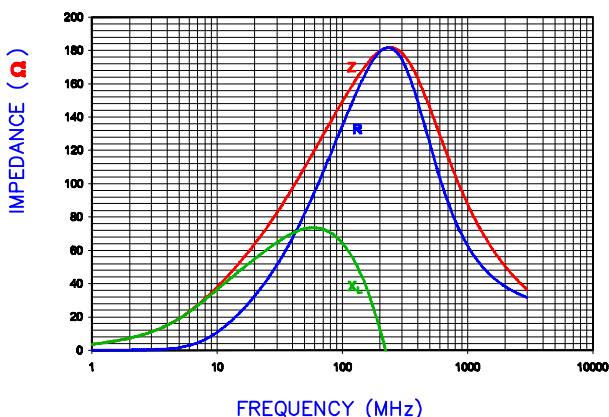

Z **R** **X_L**



AGILENT E4991A RF Impedance/Material Analyzer
HP 16194A Test Fixture. TEST REF. 3298

DIMENSIONS ARE IN mm [INCHES].

This print is the property of Laird Tech. and is loaned in confidence subject to return upon request and with the understanding that no copies shall be made without the written consent of Laird Tech. All rights to design or invention are reserved.



PROJECT/PART NUMBER: LI1206H151R-10		REV C	PART TYPE: CO-FIRE	DRAWN BY: TMB
C	UPDATE COMPANY LOGO	07/22/08	JRK	
B	CORRECT REF # FROM 3289 TO 3298	07/22/05	JRK	DATE: 04/05/04
A	ORIGINAL DRAFT	04/05/04	TMB	SCALE: NTS
REV	DESCRIPTION	DATE	INT	CAD # LI1206H151R-10-C
			TOOL #	-
				SHEET: 2 of 2