

1 11/16-18 UNEF 2A THREAD M38X1.5 6g THREAD

| REVISIONS | | | | | |
|-----------|-----|-------------------------|-----------|-------|-------|
| REV | ECO | DESCRIPTION | DATE | BY | APPR |
| A1 | -- | RELEASE NEW DRAWING | 18/OCT/18 | BROOK | TOMMY |
| A2 | -- | ADD MORE MATERIAL NOTES | 25/OCT/18 | BROOK | TOMMY |

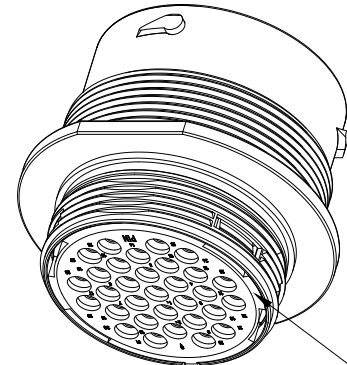
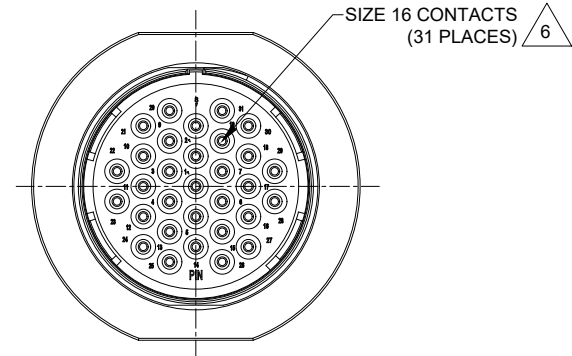

RETAINING RING - BLUE

NOTES: UNLESS OTHERWISE SPECIFIED

- MATERIAL:
SHELL: ZINC ALLOY, NICKEL PLATED
INSERT AND RETAINING RING: THERMOPLASTIC
SEAL: SILICONE RUBBER
- MODIFICATIONS: THREADED HOUSING; REDUCED DIA. WIRE SEAL
- SPECIFICATIONS:
3.1 OPERATING TEMPERATURE: -55°C TO +125°C.
3.2 DIELECTRIC WITHSTANDING VOLTAGE: LESS THAN 2 MILLIAMPS CURRENT LEAKAGE @ 1500 VOLTS AC.
3.3 INSULATION RESISTANCE: 1000 MEGOHM MIN @ 25°C.
3.4 MOISTURE RESISTANCE: IP67&IP69K (MATED CONDITION).
3.5 MATING CYCLE DURABILITY: 100 CYCLES
3.6 RoHS COMPLIANT
- MATING PART: AHDM06-24-31S* (* = SEAL TYPE)
- ALL DIMENSIONS ARE FOR REFERENCE USE ONLY.

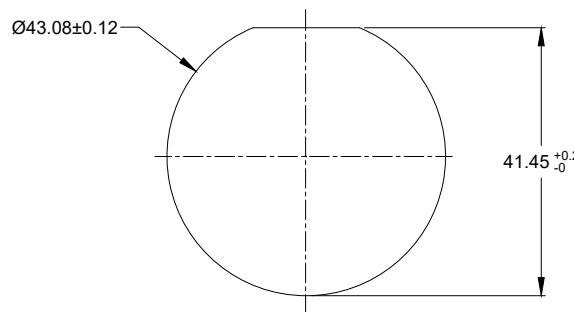

RECOMMENDED PANEL MOUNTING HOLE

RECOMMENDED PANEL THICKNESS: 1.6 TO 4.7MM

6 CONTACT SIZE AND WIRE RANGE:

| CONTACT SIZE | MIN. INSUL O.D. | MAX. INSUL O.D. | TYPICAL WIRE RANGE | CURRENT RATING |
|--------------|-------------------|-------------------|--------------------|----------------|
| 16 | 1.35 mm (.053 in) | 2.62 mm (.103 in) | 14-20 AWG | 13 AMPS |

| AHDM04-24-31PR | | DESCRIPTION | | ITEM | | | | | | | | | | | | | | | | | | | | | | | | | | | | | | | | | | | | | | | | | | | | | | | | | | | | | | | | | | | | | | | | | | | | | | | | | | | | | | | | | | | | | | | | | | |
|--|-----------------|----------------|----------|------|----------|----------------|--|--|--|----------------------------|--|--|--|--|--------------------------------------|--|--|--|--|-------------------------------|--|--|--|--|----------------|-----------------|--|--|--|----------------|------------|--|--|--|----------------|--|--|--|--|---------------------|--|--|--|--|------------|--|------|--|--|--------------|--|-----------|--|--|----------------|--|-----------|--|--|-----------|--|--|--|--|-----------------|--|-----------|--|--|--------------------------|--|--|--|--|-----------|--|--|--|--|--|--|--|--|--|-------------------------|--|--|--|--|------------|--|--|--|--|
| PART NUMBER | | DESCRIPTION | | ITEM | | | | | | | | | | | | | | | | | | | | | | | | | | | | | | | | | | | | | | | | | | | | | | | | | | | | | | | | | | | | | | | | | | | | | | | | | | | | | | | | | | | | | | | | | | |
| <table border="1"> <thead> <tr> <th>QUANTITY</th> <th colspan="4">MATERIALS LIST</th> </tr> </thead> <tbody> <tr> <td colspan="5">UNLESS OTHERWISE SPECIFIED</td> </tr> <tr> <td colspan="5">1) All dimensions are in metric(mm).</td> </tr> <tr> <td colspan="5">2) Tolerances are as follows:</td> </tr> <tr> <td>1 PL DEC ±0.30</td> <td colspan="4">Fractions ±1/64</td> </tr> <tr> <td>2 PL DEC ±0.15</td> <td colspan="4">Angles ±1°</td> </tr> <tr> <td>3 PL DEC ±0.08</td> <td colspan="4"></td> </tr> <tr> <td colspan="5">3) Note reference = </td> </tr> <tr> <td colspan="2">SIGNATURES</td> <td colspan="3">DATE</td> </tr> <tr> <td colspan="2">DRAWN: BROOK</td> <td colspan="3">25/OCT/18</td> </tr> <tr> <td colspan="2">CHECKED: ORION</td> <td colspan="3">25/OCT/18</td> </tr> <tr> <td colspan="2">ENGINEER:</td> <td colspan="3"></td> </tr> <tr> <td colspan="2">APPROVAL: TOMMY</td> <td colspan="3">25/OCT/18</td> </tr> <tr> <td colspan="5">MATERIAL SPECIFICATIONS:</td> </tr> <tr> <td colspan="5">CUSTOMER:</td> </tr> <tr> <td colspan="5">THIS DRAWING IS SUPPLIED FOR INFORMATION ONLY. DESIGN FEATURES, SPECIFICATIONS AND PERFORMANCE DATA SHOWN HEREON ARE THE PROPERTY OF THE AMPHENOL CORPORATION. NO RIGHTS OF REPRODUCTION ARE IMPLIED. ALL DIMENSIONS ARE SUBJECT TO NORMAL MANUFACTURING VARIATIONS.</td> </tr> <tr> <td colspan="5">PROCESS SPECIFICATIONS:</td> </tr> <tr> <td colspan="5">NEXT ASSY:</td> </tr> </tbody> </table> | | | | | QUANTITY | MATERIALS LIST | | | | UNLESS OTHERWISE SPECIFIED | | | | | 1) All dimensions are in metric(mm). | | | | | 2) Tolerances are as follows: | | | | | 1 PL DEC ±0.30 | Fractions ±1/64 | | | | 2 PL DEC ±0.15 | Angles ±1° | | | | 3 PL DEC ±0.08 | | | | | 3) Note reference = | | | | | SIGNATURES | | DATE | | | DRAWN: BROOK | | 25/OCT/18 | | | CHECKED: ORION | | 25/OCT/18 | | | ENGINEER: | | | | | APPROVAL: TOMMY | | 25/OCT/18 | | | MATERIAL SPECIFICATIONS: | | | | | CUSTOMER: | | | | | THIS DRAWING IS SUPPLIED FOR INFORMATION ONLY. DESIGN FEATURES, SPECIFICATIONS AND PERFORMANCE DATA SHOWN HEREON ARE THE PROPERTY OF THE AMPHENOL CORPORATION. NO RIGHTS OF REPRODUCTION ARE IMPLIED. ALL DIMENSIONS ARE SUBJECT TO NORMAL MANUFACTURING VARIATIONS. | | | | | PROCESS SPECIFICATIONS: | | | | | NEXT ASSY: | | | | |
| QUANTITY | MATERIALS LIST | | | | | | | | | | | | | | | | | | | | | | | | | | | | | | | | | | | | | | | | | | | | | | | | | | | | | | | | | | | | | | | | | | | | | | | | | | | | | | | | | | | | | | | | | | | | | |
| UNLESS OTHERWISE SPECIFIED | | | | | | | | | | | | | | | | | | | | | | | | | | | | | | | | | | | | | | | | | | | | | | | | | | | | | | | | | | | | | | | | | | | | | | | | | | | | | | | | | | | | | | | | | | | | | | |
| 1) All dimensions are in metric(mm). | | | | | | | | | | | | | | | | | | | | | | | | | | | | | | | | | | | | | | | | | | | | | | | | | | | | | | | | | | | | | | | | | | | | | | | | | | | | | | | | | | | | | | | | | | | | | | |
| 2) Tolerances are as follows: | | | | | | | | | | | | | | | | | | | | | | | | | | | | | | | | | | | | | | | | | | | | | | | | | | | | | | | | | | | | | | | | | | | | | | | | | | | | | | | | | | | | | | | | | | | | | | |
| 1 PL DEC ±0.30 | Fractions ±1/64 | | | | | | | | | | | | | | | | | | | | | | | | | | | | | | | | | | | | | | | | | | | | | | | | | | | | | | | | | | | | | | | | | | | | | | | | | | | | | | | | | | | | | | | | | | | | | |
| 2 PL DEC ±0.15 | Angles ±1° | | | | | | | | | | | | | | | | | | | | | | | | | | | | | | | | | | | | | | | | | | | | | | | | | | | | | | | | | | | | | | | | | | | | | | | | | | | | | | | | | | | | | | | | | | | | | |
| 3 PL DEC ±0.08 | | | | | | | | | | | | | | | | | | | | | | | | | | | | | | | | | | | | | | | | | | | | | | | | | | | | | | | | | | | | | | | | | | | | | | | | | | | | | | | | | | | | | | | | | | | | | | |
| 3) Note reference = | | | | | | | | | | | | | | | | | | | | | | | | | | | | | | | | | | | | | | | | | | | | | | | | | | | | | | | | | | | | | | | | | | | | | | | | | | | | | | | | | | | | | | | | | | | | | | |
| SIGNATURES | | DATE | | | | | | | | | | | | | | | | | | | | | | | | | | | | | | | | | | | | | | | | | | | | | | | | | | | | | | | | | | | | | | | | | | | | | | | | | | | | | | | | | | | | | | | | | | | | |
| DRAWN: BROOK | | 25/OCT/18 | | | | | | | | | | | | | | | | | | | | | | | | | | | | | | | | | | | | | | | | | | | | | | | | | | | | | | | | | | | | | | | | | | | | | | | | | | | | | | | | | | | | | | | | | | | | |
| CHECKED: ORION | | 25/OCT/18 | | | | | | | | | | | | | | | | | | | | | | | | | | | | | | | | | | | | | | | | | | | | | | | | | | | | | | | | | | | | | | | | | | | | | | | | | | | | | | | | | | | | | | | | | | | | |
| ENGINEER: | | | | | | | | | | | | | | | | | | | | | | | | | | | | | | | | | | | | | | | | | | | | | | | | | | | | | | | | | | | | | | | | | | | | | | | | | | | | | | | | | | | | | | | | | | | | | | |
| APPROVAL: TOMMY | | 25/OCT/18 | | | | | | | | | | | | | | | | | | | | | | | | | | | | | | | | | | | | | | | | | | | | | | | | | | | | | | | | | | | | | | | | | | | | | | | | | | | | | | | | | | | | | | | | | | | | |
| MATERIAL SPECIFICATIONS: | | | | | | | | | | | | | | | | | | | | | | | | | | | | | | | | | | | | | | | | | | | | | | | | | | | | | | | | | | | | | | | | | | | | | | | | | | | | | | | | | | | | | | | | | | | | | | |
| CUSTOMER: | | | | | | | | | | | | | | | | | | | | | | | | | | | | | | | | | | | | | | | | | | | | | | | | | | | | | | | | | | | | | | | | | | | | | | | | | | | | | | | | | | | | | | | | | | | | | | |
| THIS DRAWING IS SUPPLIED FOR INFORMATION ONLY. DESIGN FEATURES, SPECIFICATIONS AND PERFORMANCE DATA SHOWN HEREON ARE THE PROPERTY OF THE AMPHENOL CORPORATION. NO RIGHTS OF REPRODUCTION ARE IMPLIED. ALL DIMENSIONS ARE SUBJECT TO NORMAL MANUFACTURING VARIATIONS. | | | | | | | | | | | | | | | | | | | | | | | | | | | | | | | | | | | | | | | | | | | | | | | | | | | | | | | | | | | | | | | | | | | | | | | | | | | | | | | | | | | | | | | | | | | | | | |
| PROCESS SPECIFICATIONS: | | | | | | | | | | | | | | | | | | | | | | | | | | | | | | | | | | | | | | | | | | | | | | | | | | | | | | | | | | | | | | | | | | | | | | | | | | | | | | | | | | | | | | | | | | | | | | |
| NEXT ASSY: | | | | | | | | | | | | | | | | | | | | | | | | | | | | | | | | | | | | | | | | | | | | | | | | | | | | | | | | | | | | | | | | | | | | | | | | | | | | | | | | | | | | | | | | | | | | | | |
| <p>Sine Systems - www.amphenol-sine.com 44724 Morley Drive Clinton Township, MI 48036</p> | | | | | | | | | | | | | | | | | | | | | | | | | | | | | | | | | | | | | | | | | | | | | | | | | | | | | | | | | | | | | | | | | | | | | | | | | | | | | | | | | | | | | | | | | | | | | | |
| <p>RCPT, 24 SZ 31 PIN, RD, WIDE THD</p> | | | | | | | | | | | | | | | | | | | | | | | | | | | | | | | | | | | | | | | | | | | | | | | | | | | | | | | | | | | | | | | | | | | | | | | | | | | | | | | | | | | | | | | | | | | | | | |
| SIZE | TYPE | DWG NO. | REVISION | | | | | | | | | | | | | | | | | | | | | | | | | | | | | | | | | | | | | | | | | | | | | | | | | | | | | | | | | | | | | | | | | | | | | | | | | | | | | | | | | | | | | | | | | | | |
| B | C- | AHDM04-24-31PR | A2 | | | | | | | | | | | | | | | | | | | | | | | | | | | | | | | | | | | | | | | | | | | | | | | | | | | | | | | | | | | | | | | | | | | | | | | | | | | | | | | | | | | | | | | | | | | |
| SCALE: NONE | | SHEET 1 OF 1 | | | | | | | | | | | | | | | | | | | | | | | | | | | | | | | | | | | | | | | | | | | | | | | | | | | | | | | | | | | | | | | | | | | | | | | | | | | | | | | | | | | | | | | | | | | | |

TITLE: RCPT, 24 SZ 31 PIN, RD, WIDE THD DWG NO.: AHDM04-24-31PR REV: A2 SH: 1 OF: 1

A Series™ - Contact Size 16 Options (Works with: AT, ATV, AHD-9, ARC, DuraMate and PanelMate Series)

| Machined Contacts, Sockets & Pins | | | | |
|-----------------------------------|--|------|-------|----------|
| Part Number | Description | Size | AWG | Type |
| AT60-215-1631 | Male Contact - Pin, Gold-plated | 16 | 14 | Machined |
| AT62-209-1631 | Female Contact - Socket, Gold-plated | 16 | 14 | Machined |
| AT60-215-16141 | Male Contact - Pin, Nickel-plated | 16 | 14 | Machined |
| AT62-209-16141 | Female Contact - Socket, Nickel-plated | 16 | 14 | Machined |
| AT60-202-1631 | Male Contact - Pin, Gold-plated | 16 | 16-20 | Machined |
| AT62-201-1631 | Female Contact - Socket, Gold-plated | 16 | 16-20 | Machined |
| AT60-202-16141 | Male Contact - Pin, Nickel-plated | 16 | 16-20 | Machined |
| AT62-201-16141 | Female Contact - Socket, Nickel-plated | 16 | 16-20 | Machined |
| AT60-202-1631-22 | Male Contact - Pin, Gold-plated | 16 | 22-24 | Machined |
| AT62-201-1631-22 | Female Contact - Socket, Gold-plated | 16 | 22-24 | Machined |
| AT60-202-16141-22 | Male Contact - Pin, Nickel-plated | 16 | 22-24 | Machined |
| AT62-201-16141-22 | Female Contact - Socket, Nickel-plated | 16 | 22-24 | Machined |

| Tooling - Machined Contacts | |
|-----------------------------|---|
| Part Number | Description |
| AUTK-16 | Hand Crimp Tool, Size 16 |
| AUTK-100 | Universal Heavy Duty Contact Crimping Tool Kit, Size 12/16/20 |
| CA-5D12 | Universal Hand Crimp Tool, Size 12/16/20 |
| CA-5E12 | Pneumatic Crimp Tool, Size 12/16/20 |

| Contact Removal Tools (For both Machined or Stamped & Formed Contacts) | |
|--|--|
| Part Number | Description |
| ATRT-100 | Contact and Wedgelock Extraction Tool |
| AT11-310-1605 | Contact Removal Tool, Plastic, Size 16 |

| Sealing Plugs (For both Machined or Stamped & Formed Contacts) | |
|--|---|
| Part Number | Description |
| A114017 | Sealing Plug, Size 16, White |
| A114017-SR | Sealing Plug, Size 16, SR01 Series, Black |
| AT13-217-1605 | Locking Sealing Plug, Size 16, Grey |
| AT13-217-1605-SR | Locking Sealing Plug, Size 16, SR01 Series, Red |

| Stamped & Formed Contacts, Sockets & Pins | | | | |
|---|--|------|-------|------------------|
| Part Number | Description | Size | AWG | Type |
| AT60-14-0122 | Male Contact - Pin, Nickel-plated | 16 | 14-18 | Stamped & Formed |
| AT62-14-0122 | Female Contact - Socket, Nickel-plated | 16 | 14-18 | Stamped & Formed |
| AT60-14-0144 | Male Contact - Pin, Gold-plated | 16 | 14-18 | Stamped & Formed |
| AT62-14-0144 | Female Contact - Socket, Gold-plated | 16 | 14-18 | Stamped & Formed |
| AT60-16-0122 | Male Contact - Pin, Nickel-plated | 16 | 16-18 | Stamped & Formed |
| AT62-16-0122 | Female Contact - Socket, Nickel-plated | 16 | 16-18 | Stamped & Formed |
| AT60-16-0144 | Male Contact - Pin, Gold-plated | 16 | 16-18 | Stamped & Formed |
| AT62-16-0144 | Female Contact - Socket, Gold-plated | 16 | 16-18 | Stamped & Formed |
| AT60-16-0622 | Male Contact - Pin, Nickel-plated | 16 | 16-20 | Stamped & Formed |
| AT62-16-0622 | Female Contact - Socket, Nickel-plated | 16 | 16-20 | Stamped & Formed |
| AT60-16-0644 | Male Contact - Pin, Gold-plated | 16 | 16-20 | Stamped & Formed |
| AT62-16-0644 | Female Contact - Socket, Gold-plated | 16 | 16-20 | Stamped & Formed |
| AT60-16-0677 | Male Contact - Pin, Tin-plated | 16 | 16-20 | Stamped & Formed |
| AT62-16-0677 | Female Contact - Socket, Tin-plated | 16 | 16-20 | Stamped & Formed |
| AT60-16-0822 | Male Contact - Pin, Nickel-plated | 16 | 20-22 | Stamped & Formed |
| AT62-16-0822 | Female Contact - Socket, Nickel-plated | 16 | 20-22 | Stamped & Formed |
| AT60-16-0844 | Male Contact - Pin, Gold-plated | 16 | 20-22 | Stamped & Formed |
| AT62-16-0844 | Female Contact - Socket, Gold-plated | 16 | 20-22 | Stamped & Formed |

| Tooling - Stamped & Formed Contacts | |
|-------------------------------------|-------------------------------------|
| MFX-3950 | Crimp Die - Size 16, 18-20AWG |
| MFX-3953 | Crimp Die - Size 16, 16-18AWG |
| MFX-3975 | Crimp Die - Size 16, 14-16AWG |
| MFX-3990 | Crimp Die - Size 16, 20-22AWG |
| ATT-16-00 | Hand Crimp Tool - Size 16, 14-16AWG |
| ATT-16-01 | Hand Crimp Tool - Size 16, 18-20AWG |
| ATT-1612-03 | Hand Crimp Tool - Size 16, 20-22AWG |