

## LM833-N Dual Audio Operational Amplifier

Check for Samples: [LM833-N](#)

### FEATURES

- **Wide Dynamic Range:** >140dB
- **Low Input Noise Voltage:**  $4.5\text{nV}/\sqrt{\text{Hz}}$
- **High Slew Rate:**  $7\text{ V}/\mu\text{s}$  (typ);  $5\text{ V}/\mu\text{s}$  (Min)
- **High Gain Bandwidth:**  $15\text{MHz}$  (typ);  $10\text{MHz}$  (Min)
- **Wide Power Bandwidth:**  $120\text{KHz}$
- **Low Distortion:**  $0.002\%$
- **Low Offset Voltage:**  $0.3\text{mV}$
- **Large Phase Margin:**  $60^\circ$
- **Available in 8 Pin VSSOP Package**

### DESCRIPTION

The LM833-N is a dual general purpose operational amplifier designed with particular emphasis on performance in audio systems.

This dual amplifier IC utilizes new circuit and processing techniques to deliver low noise, high speed and wide bandwidth without increasing external components or decreasing stability. The LM833-N is internally compensated for all closed loop gains and is therefore optimized for all preamp and high level stages in PCM and HiFi systems.

The LM833-N is pin-for-pin compatible with industry standard dual operational amplifiers.

### Schematic Diagram

(1/2 LM833-N)

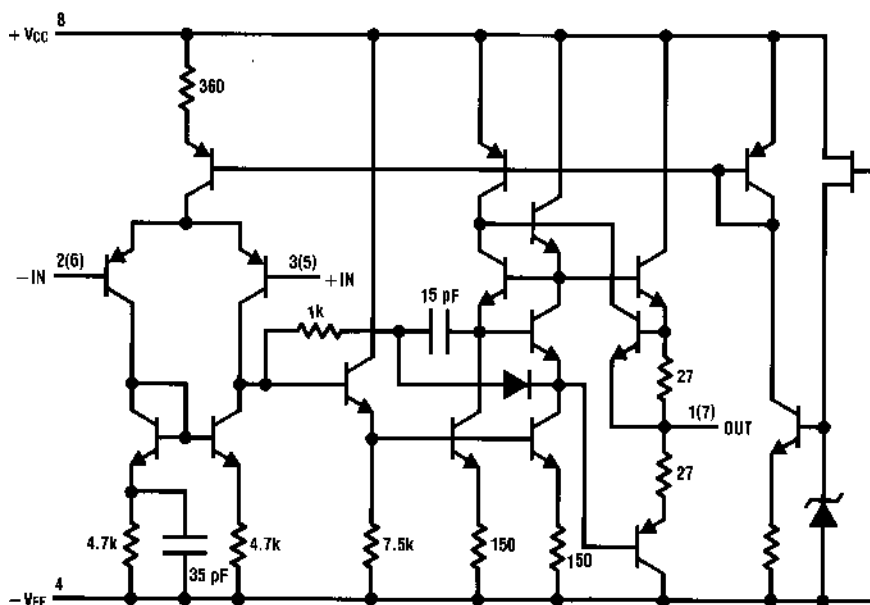

Please be aware that an important notice concerning availability, standard warranty, and use in critical applications of Texas Instruments semiconductor products and disclaimers thereto appears at the end of this data sheet.

All trademarks are the property of their respective owners.

## Connection Diagram

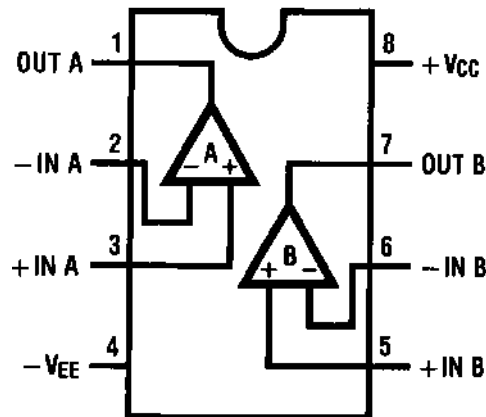

Figure 1. See Package Number D0008A, P0008E or DGK0008A



These devices have limited built-in ESD protection. The leads should be shorted together or the device placed in conductive foam during storage or handling to prevent electrostatic damage to the MOS gates.

### ABSOLUTE MAXIMUM RATINGS<sup>(1)(2)</sup>

Supply Voltage $V_{CC}-V_{EE}$		36V	
Differential Input Voltage <sup>(3)</sup> $V_I$		$\pm 30V$	
Input Voltage Range <sup>(3)</sup> $V_{IC}$		$\pm 15V$	
Power Dissipation <sup>(4)</sup> $P_D$		500 mW	
Operating Temperature Range $T_{OPR}$		$-40 \sim 85^\circ C$	
Storage Temperature Range $T_{STG}$		$-60 \sim 150^\circ C$	
Soldering Information	PDIP Package	Soldering (10 seconds)	260°C
	Small Outline Package (SOIC and VSSOP)	Vapor Phase (60 seconds)	215°C
		Infrared (15 seconds)	220°C
ESD tolerance <sup>(5)</sup>		1600V	

- (1) *Absolute Maximum Ratings* indicate limits beyond which damage to the device may occur. *Operating Ratings* indicate conditions for which the device is functional, but do not ensure specific performance limits. *Electrical Characteristics* state DC and AC electrical specifications under particular test conditions which ensure specific performance limits. This assumes that the device is within the Operating Ratings. Specifications are not ensured for parameters where no limit is given, however, the typical value is a good indication of device performance.
- (2) If Military/Aerospace specified devices are required, please contact the Texas Instruments Sales Office/ Distributors for availability and specifications.
- (3) If supply voltage is less than  $\pm 15V$ , it is equal to supply voltage.
- (4) This is the permissible value at  $T_A \leq 85^\circ C$ .
- (5) Human body model, 1.5 k $\Omega$  in series with 100 pF.

## DC ELECTRICAL CHARACTERISTICS<sup>(1)(2)</sup>

 $(T_A = 25^\circ\text{C}, V_S = \pm 15\text{V})$ 

Symbol	Parameter	Conditions	Min	Typ	Max	Units
$V_{OS}$	Input Offset Voltage	$R_S = 10\Omega$		0.3	5	mV
$I_{OS}$	Input Offset Current			10	200	nA
$I_B$	Input Bias Current			500	1000	nA
$A_V$	Voltage Gain	$R_L = 2\text{ k}\Omega, V_O = \pm 10\text{V}$	90	110		dB
$V_{OM}$	Output Voltage Swing	$R_L = 10\text{ k}\Omega$	$\pm 12$	$\pm 13.5$		V
		$R_L = 2\text{ k}\Omega$	$\pm 12$	$\pm 13.4$		V
$V_{CM}$	Input Common-Mode Range		$\pm 12$	$\pm 14.0$		V
CMRR	Common-Mode Rejection Ratio	$V_{IN} = \pm 12\text{V}$	80	100		dB
PSRR	Power Supply Rejection Ratio	$V_S = 15 \sim 5\text{V}, -15 \sim -5\text{V}$	80	100		dB
$I_Q$	Supply Current	$V_O = 0\text{V}, \text{Both Amps}$		5	8	mA

- (1) *Absolute Maximum Ratings* indicate limits beyond which damage to the device may occur. *Operating Ratings* indicate conditions for which the device is functional, but do not ensure specific performance limits. *Electrical Characteristics* state DC and AC electrical specifications under particular test conditions which ensure specific performance limits. This assumes that the device is within the Operating Ratings. Specifications are not ensured for parameters where no limit is given, however, the typical value is a good indication of device performance.
- (2) All voltages are measured with respect to the ground pin, unless otherwise specified.

## AC ELECTRICAL CHARACTERISTICS

 $(T_A = 25^\circ\text{C}, V_S = \pm 15\text{V}, R_L = 2\text{ k}\Omega)$ 

Symbol	Parameter	Conditions	Min	Typ	Max	Units
SR	Slew Rate	$R_L = 2\text{ k}\Omega$	5	7		V/ $\mu\text{s}$
GBW	Gain Bandwidth Product	$f = 100\text{ kHz}$	10	15		MHz
$V_{NI}$	Equivalent Input Noise Voltage (LM833AM, LM833AMX)	RIAA, $R_S = 2.2\text{ k}\Omega$ <sup>(1)</sup>			1.4	$\mu\text{V}$

- (1) RIAA Noise Voltage Measurement Circuit

## DESIGN ELECTRICAL CHARACTERISTICS

 $(T_A = 25^\circ\text{C}, V_S = \pm 15\text{V})$ 

The following parameters are not tested or ensured.

Symbol	Parameter	Conditions	Typ	Units
$\Delta V_{OS}/\Delta T$	Average Temperature Coefficient of Input Offset Voltage		2	$\mu\text{V}/^\circ\text{C}$
THD	Distortion	$R_L = 2\text{ k}\Omega, f = 20\sim 20\text{ kHz}$ $V_{OUT} = 3\text{ V}_{rms}, A_V = 1$	0.002	%
$e_n$	Input Referred Noise Voltage	$R_S = 100\Omega, f = 1\text{ kHz}$	4.5	$\text{nV} / \sqrt{\text{Hz}}$
$i_n$	Input Referred Noise Current	$f = 1\text{ kHz}$	0.7	$\text{pA} / \sqrt{\text{Hz}}$
PBW	Power Bandwidth	$V_O = 27\text{ V}_{pp}, R_L = 2\text{ k}\Omega, \text{THD} \leq 1\%$	120	kHz
$f_U$	Unity Gain Frequency	Open Loop	9	MHz
$\phi_M$	Phase Margin	Open Loop	60	deg
	Input Referred Cross Talk	$f = 20\sim 20\text{ kHz}$	-120	dB

TYPICAL PERFORMANCE CHARACTERISTICS

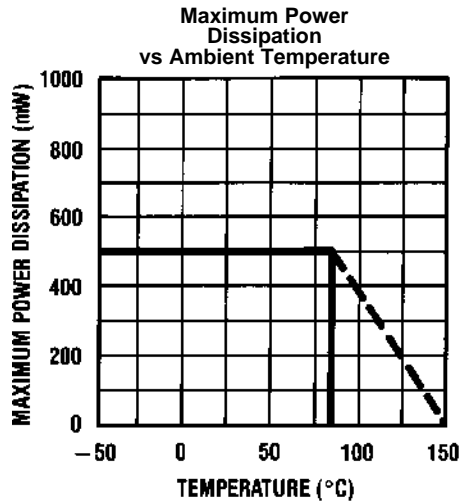

Figure 2.

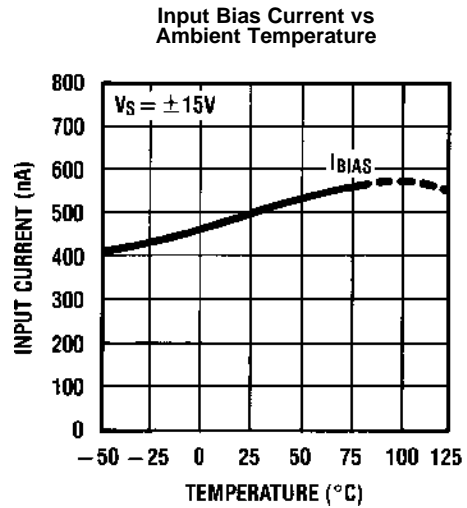

Figure 3.

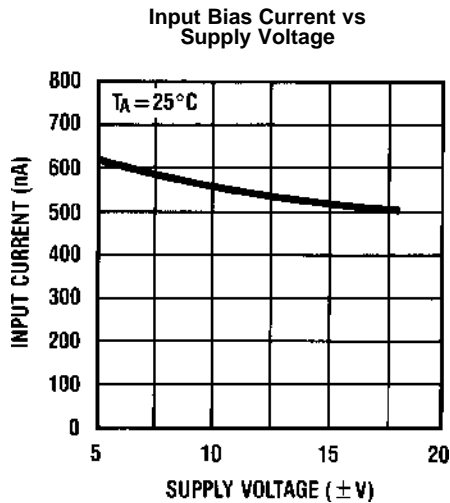

Figure 4.

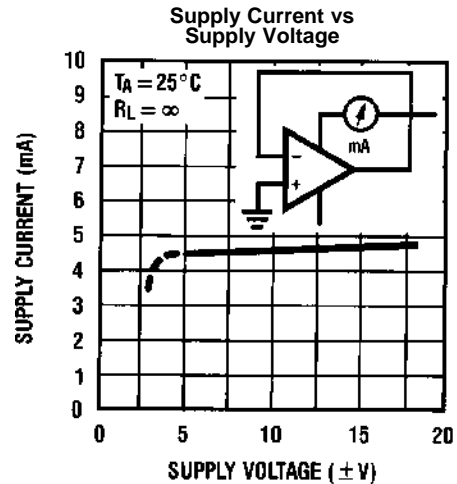

Figure 5.

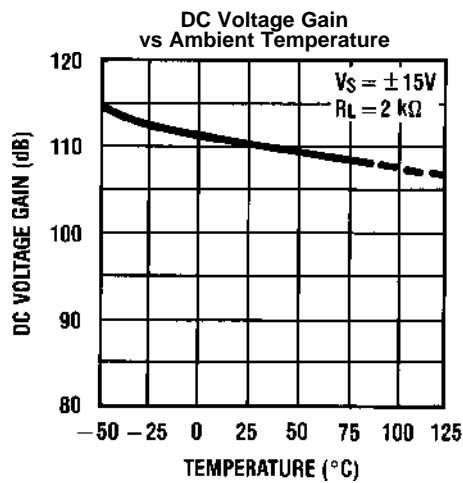

Figure 6.

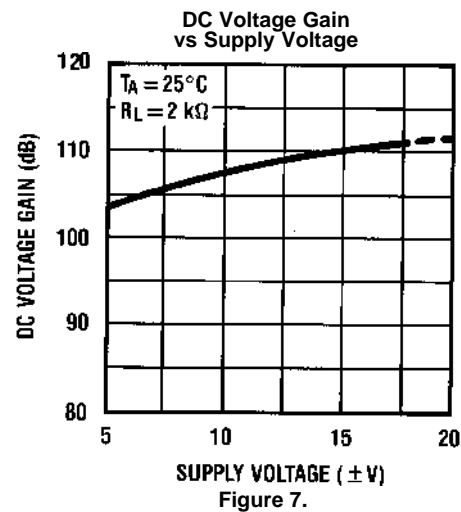
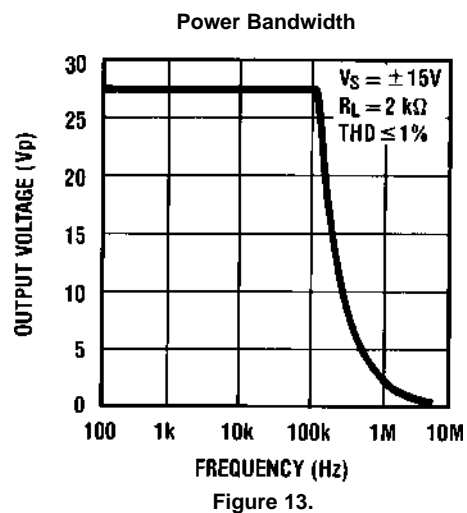
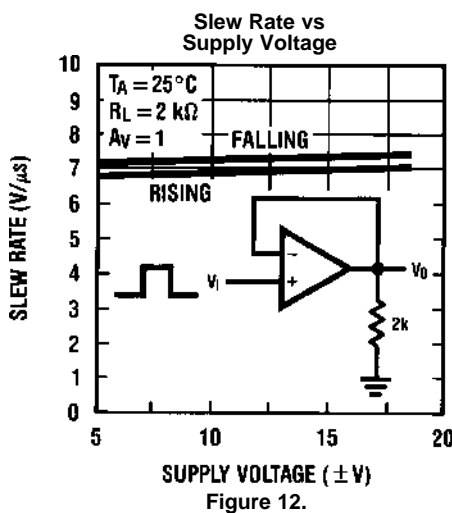
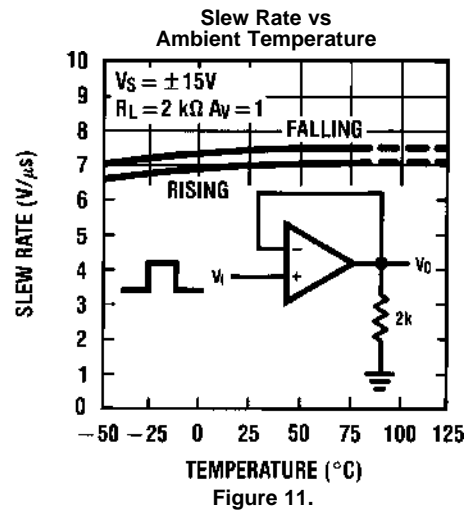
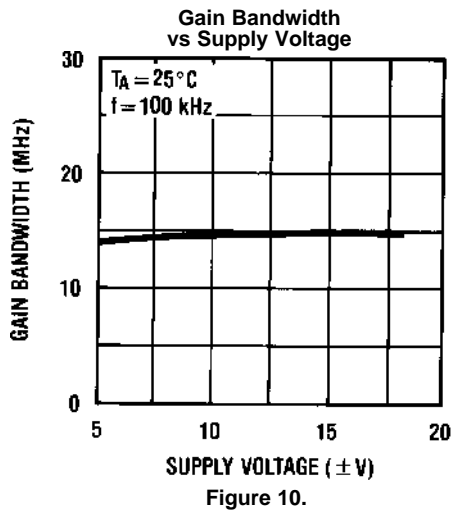
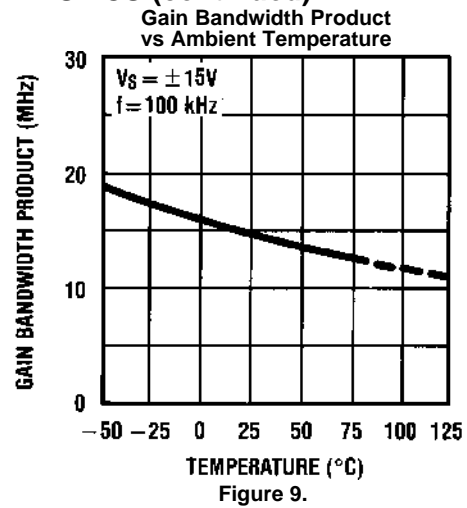
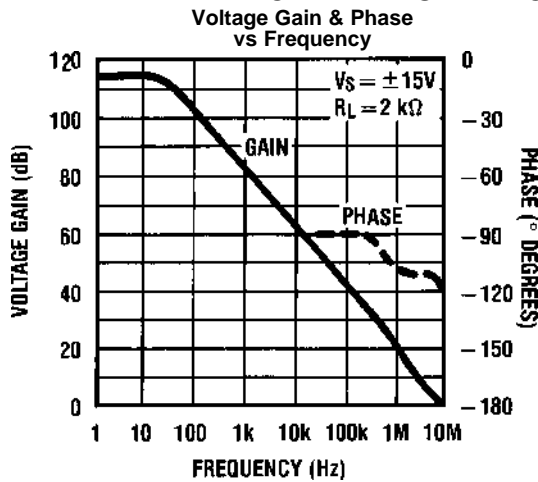
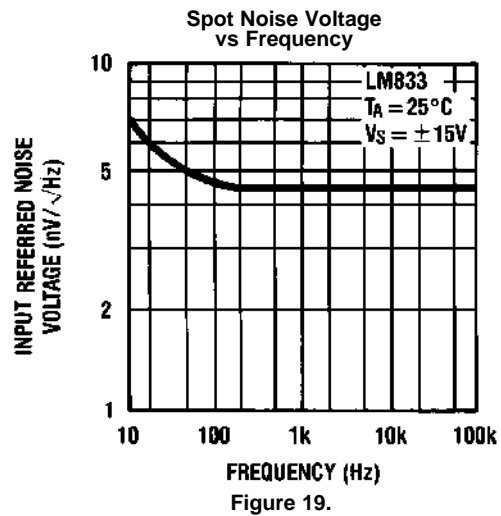
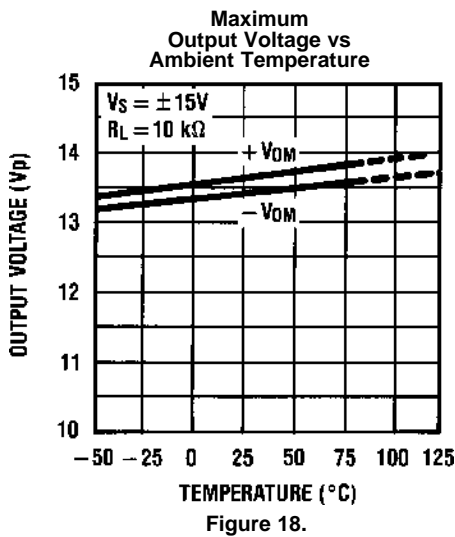
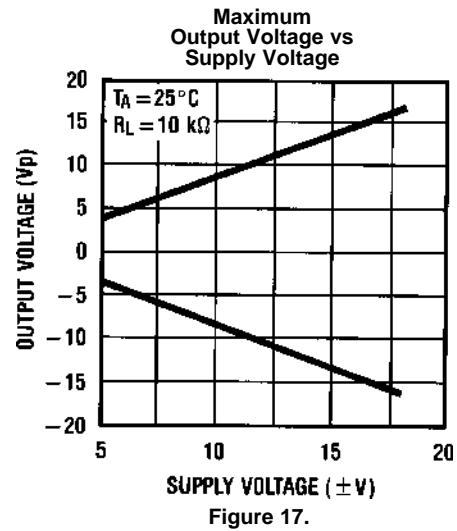
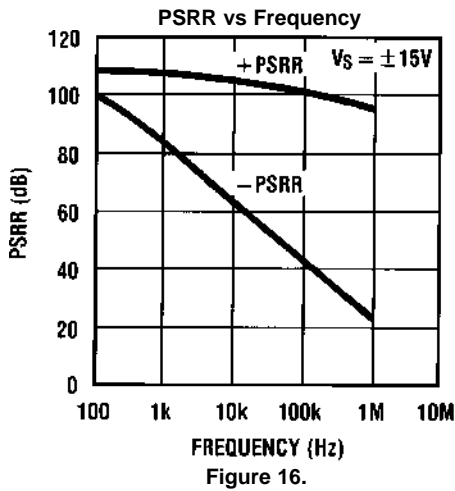
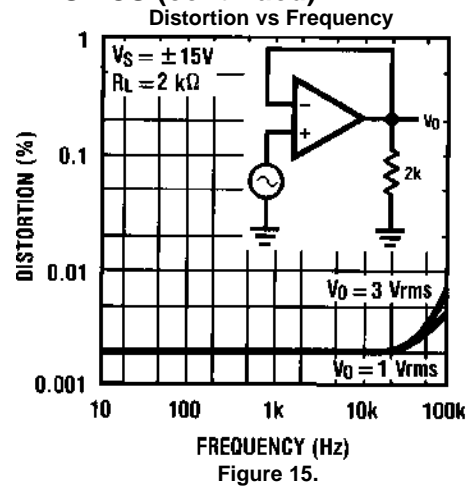
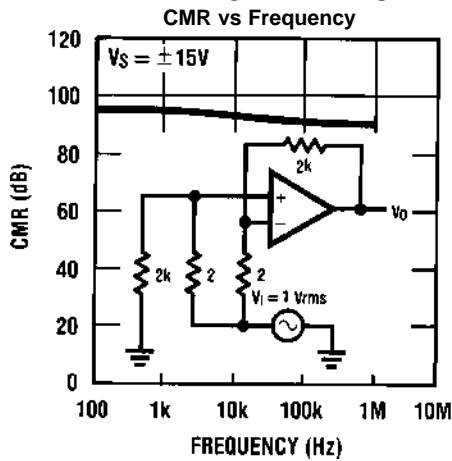

Figure 7.

**TYPICAL PERFORMANCE CHARACTERISTICS (continued)**



**TYPICAL PERFORMANCE CHARACTERISTICS (continued)**



TYPICAL PERFORMANCE CHARACTERISTICS (continued)

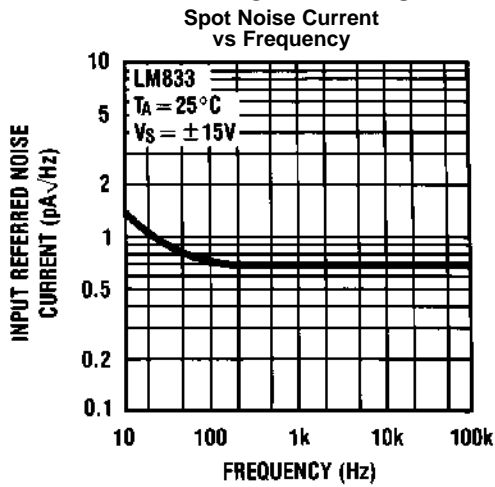

Figure 20.

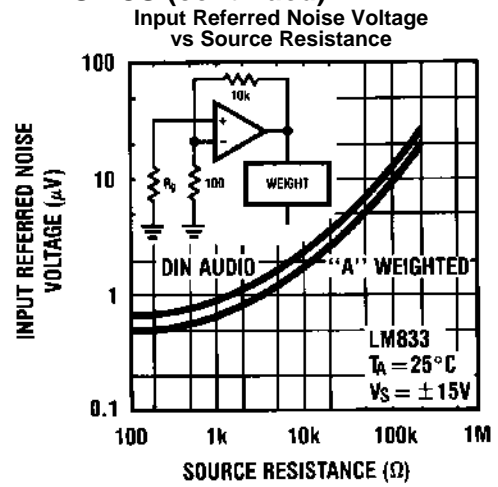

Figure 21.

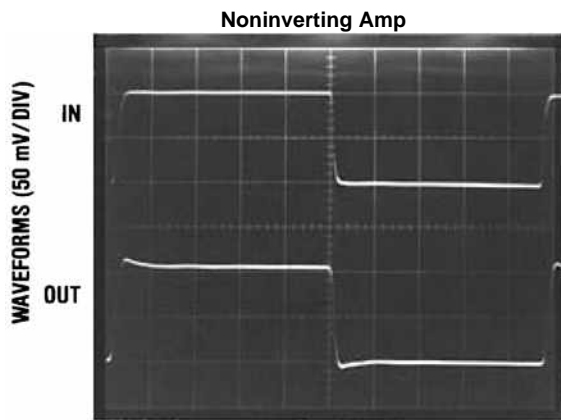

Figure 22.

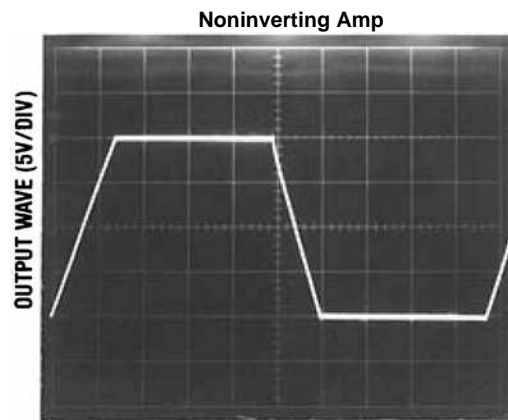

Figure 23.

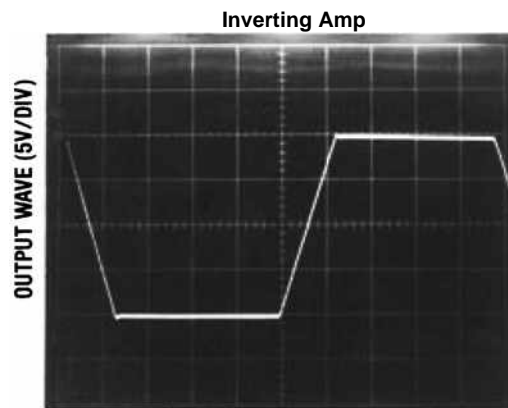

Figure 24.

### APPLICATION HINTS

The LM833-N is a high speed op amp with excellent phase margin and stability. Capacitive loads up to 50 pF will cause little change in the phase characteristics of the amplifiers and are therefore allowable.

Capacitive loads greater than 50 pF must be isolated from the output. The most straightforward way to do this is to put a resistor in series with the output. This resistor will also prevent excess power dissipation if the output is accidentally shorted.

### Noise Measurement Circuit

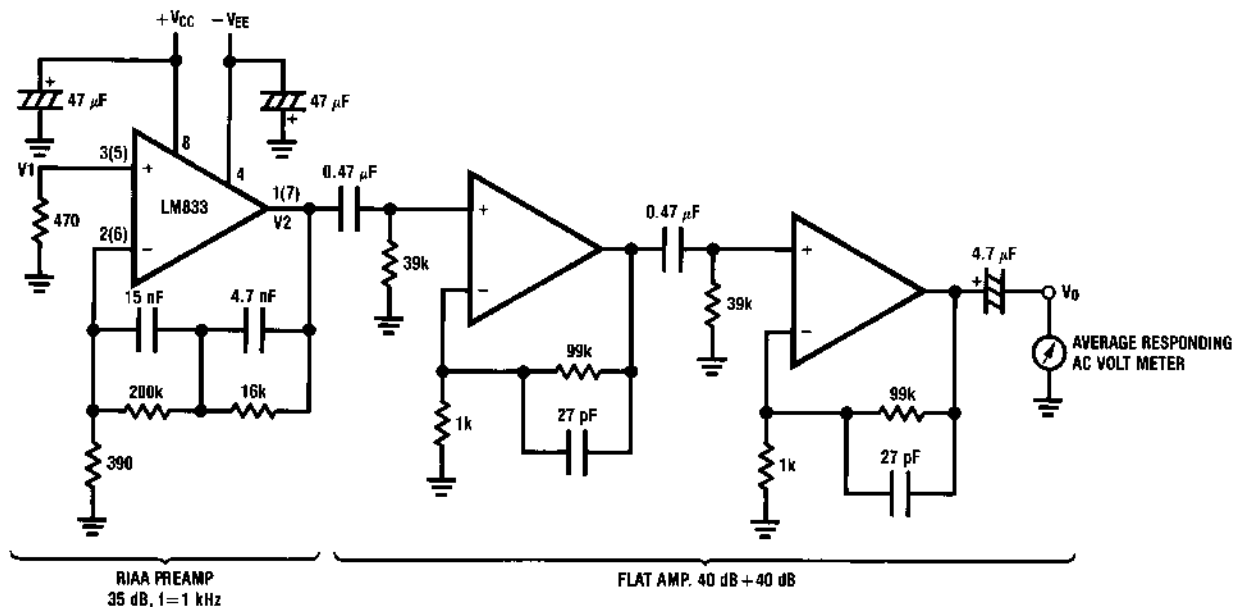

Complete shielding is required to prevent induced pick up from external sources. Always check with oscilloscope for power line noise.

**Figure 25. Total Gain: 115 dB @f = 1 kHz  
Input Referred Noise Voltage:  $e_n = V_0/560,000$  (V)**



RIAA Noise Voltage Measurement Circuit

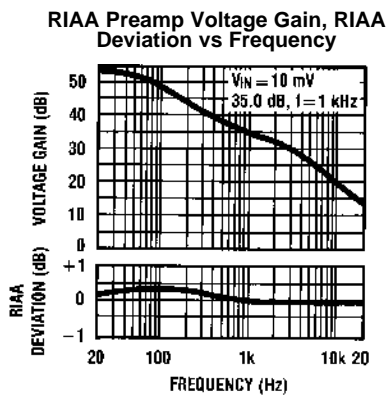
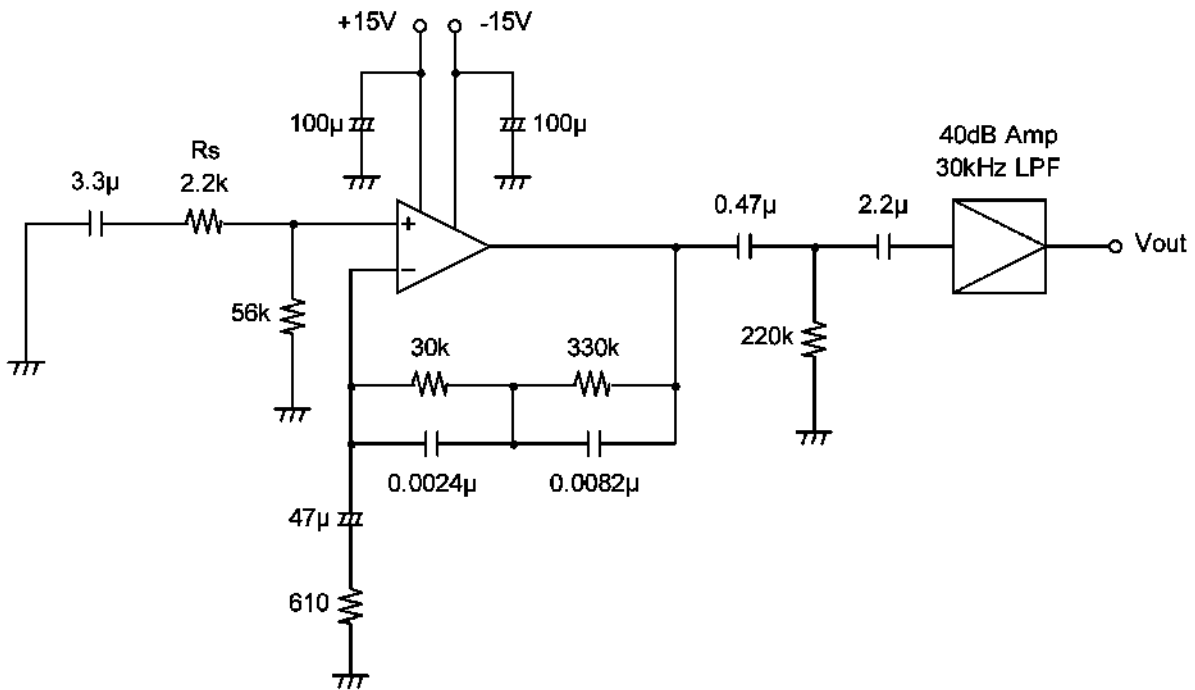

Figure 26.

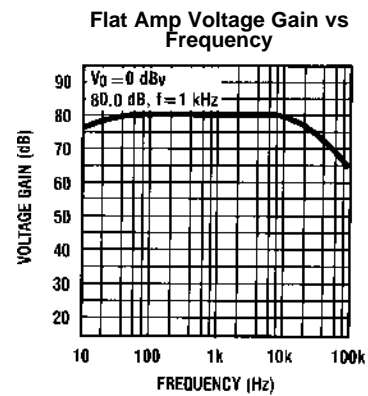
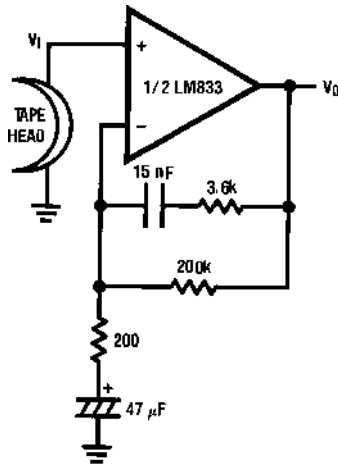

Figure 27.

Typical Applications



$A_V = 34.5$   
 $F = 1 \text{ kHz}$   
 $E_n = 0.38 \mu\text{V}$   
 A Weighted

Figure 28. NAB Preamp

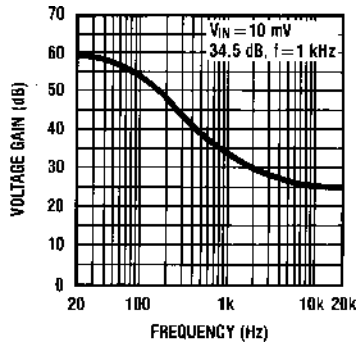
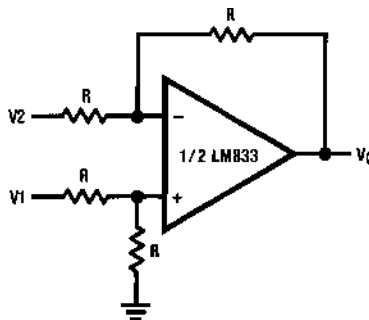
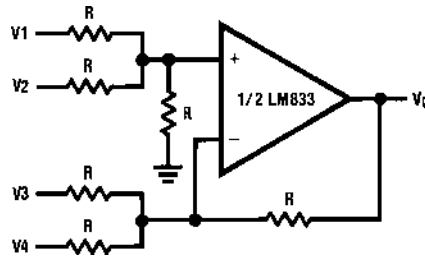

Figure 29. NAB Preamp Voltage Gain vs Frequency



$V_0 = V1 - V2$

Figure 30. Balanced to Single Ended Converter



$$V_O = V_1 + V_2 - V_3 - V_4$$

Figure 31. Adder/Subtracter

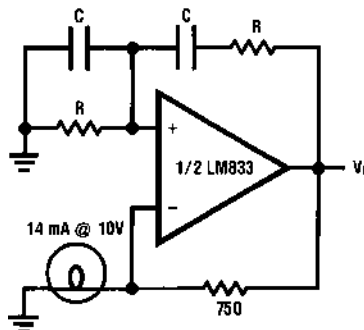

$$f_0 = \frac{1}{2\pi RC}$$

Figure 32. Sine Wave Oscillator

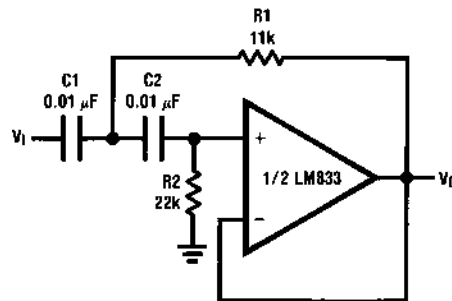

if  $C_1 = C_2 = C$

$$R_1 = \frac{\sqrt{2}}{2\omega_c C}$$

$$R_2 = 2 \cdot R_1$$

Illustration is  $f_0 = 1 \text{ kHz}$

Figure 33. Second Order High Pass Filter (Butterworth)

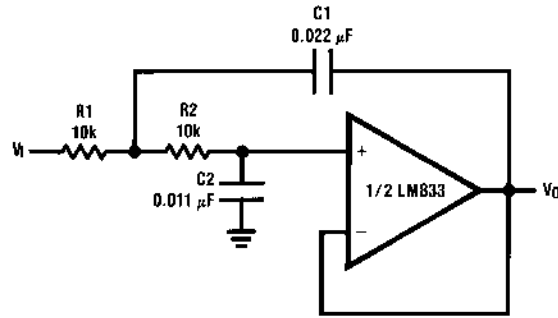

if  $R1 = R2 = R$

$$C1 = \frac{\sqrt{2}}{\omega_c R}$$

$$C2 = \frac{C1}{2}$$

Illustration is  $f_0 = 1 \text{ kHz}$

Figure 34. Second Order Low Pass Filter (Butterworth)

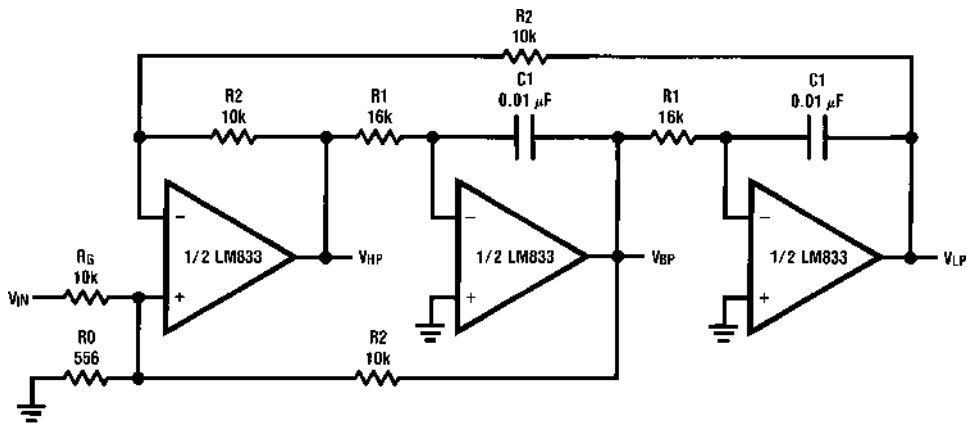

$$f_0 = \frac{1}{2\pi C1 R1}, Q = \frac{1}{2} \left( 1 + \frac{R2}{R0} + \frac{R2}{R1} \right), A_{BP} = Q A_{LP} = Q A_{LH} = \frac{R2}{R0}$$

Illustration is  $f_0 = 1 \text{ kHz}, Q = 10, A_{BP} = 1$

Figure 35. State Variable Filter

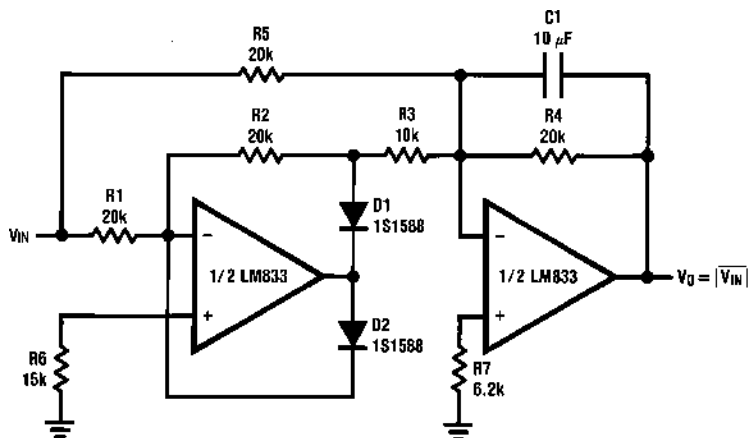

Figure 36. AC/DC Converter

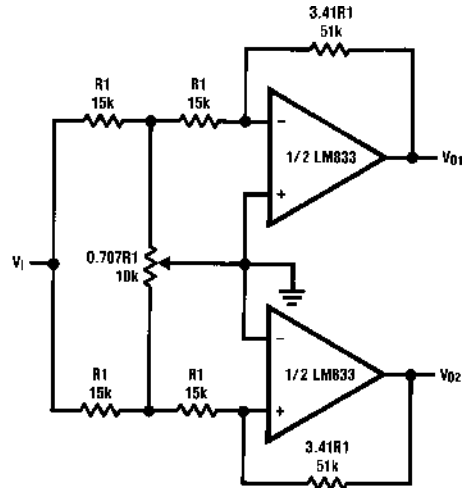

Figure 37. 2 Channel Panning Circuit (Pan Pot)

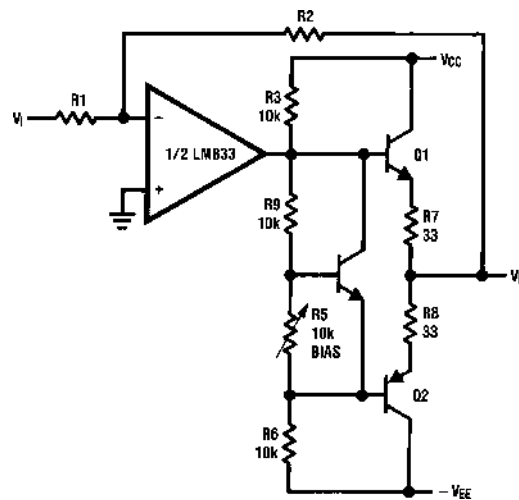
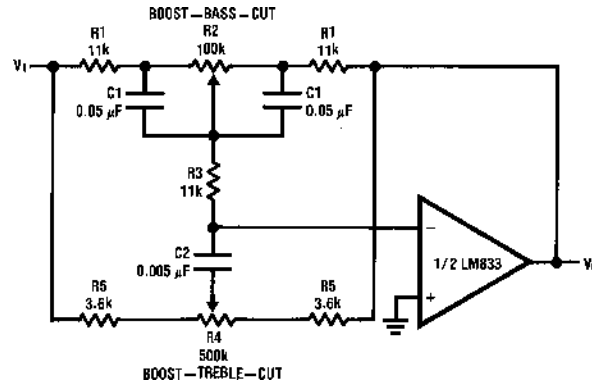

Figure 38. Line Driver



$$f_L = \frac{1}{2\pi R_2 C_1}, f_{LB} = \frac{1}{2\pi R_1 C_1}$$

$$f_H = \frac{1}{2\pi R_5 C_2}, f_{HB} = \frac{1}{2\pi (R_1 + R_5 + 2R_3) C_2}$$

Illustration is:

$f_L = 32 \text{ Hz}$ ,  $f_{LB} = 320 \text{ Hz}$   
 $f_H = 11 \text{ kHz}$ ,  $f_{HB} = 1.1 \text{ kHz}$

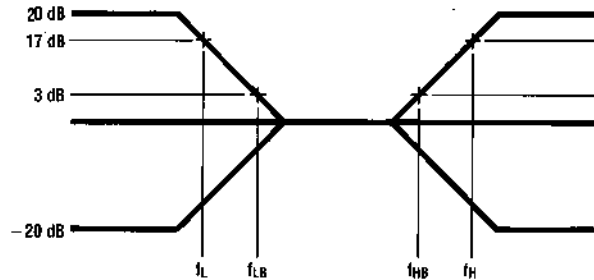
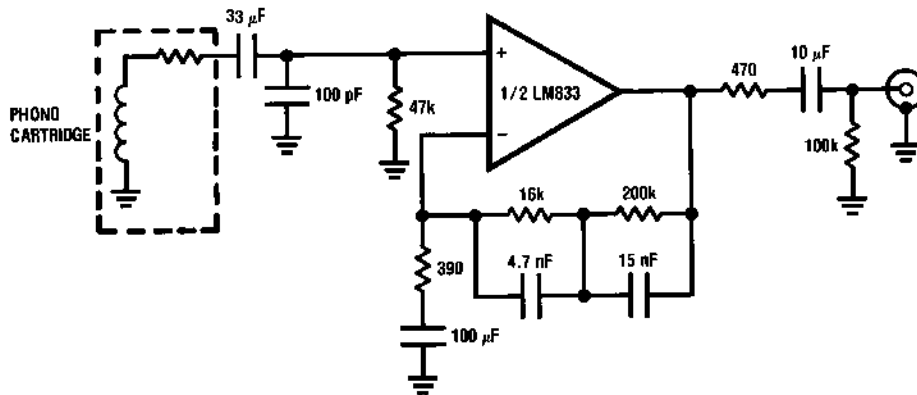
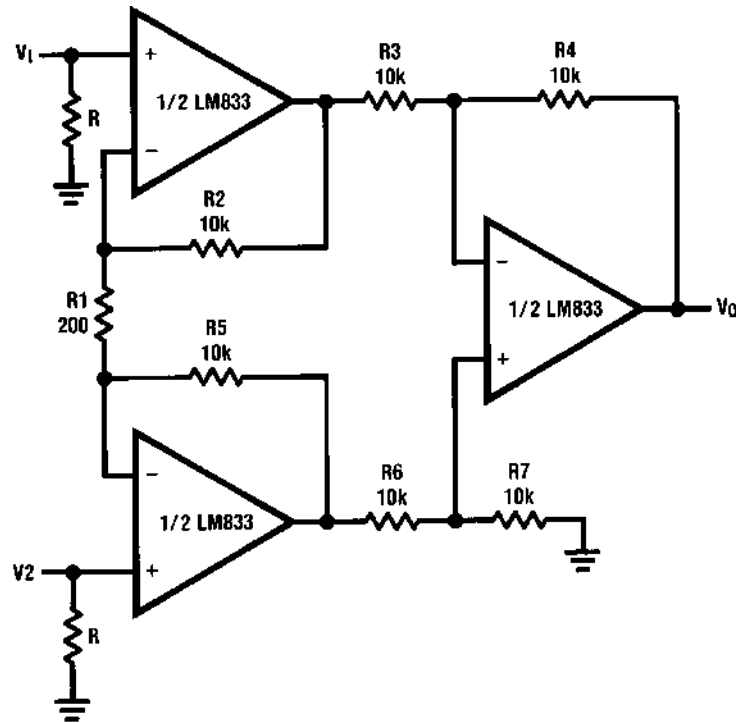

Figure 39. Tone Control



$A_v = 35 \text{ dB}$   
 $E_n = 0.33 \mu\text{V}$   
 $S/N = 90 \text{ dB}$   
 $f = 1 \text{ kHz}$   
 A Weighted  
 A Weighted,  $V_{IN} = 10 \text{ mV}$   
 @  $f = 1 \text{ kHz}$

Figure 40. RIAA Preamp



$$\# R2 = R5, R3 = R6, R4 = R7$$

$$V_0 = \left( 1 + \frac{2R2}{R1} \right) \frac{R4}{R3} (V2 - V1)$$

Illustration is:  
 $V_0 = 101(V2 - V1)$

Figure 41. Balanced Input Mic Amp

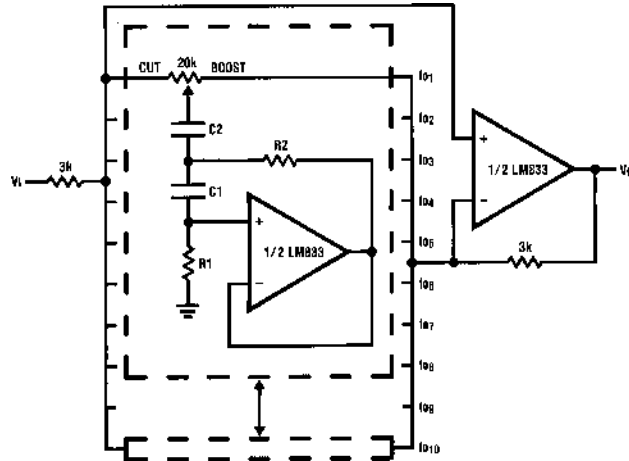

Figure 42. 10 Band Graphic Equalizer

fo (Hz)	C <sub>1</sub>	C <sub>2</sub>	R <sub>1</sub>	R <sub>2</sub>
32	0.12μF	4.7μF	75kΩ	500Ω
64	0.056μF	3.3μF	68kΩ	510Ω
125	0.033μF	1.5μF	62kΩ	510Ω
250	0.015μF	0.82μF	68kΩ	470Ω
500	8200pF	0.39μF	62kΩ	470Ω
1k	3900pF	0.22μF	68kΩ	470Ω
2k	2000pF	0.1μF	68kΩ	470Ω
4k	1100pF	0.056μF	62kΩ	470Ω
8k	510pF	0.022μF	68kΩ	510Ω
16k	330pF	0.012μF	51kΩ	510Ω

**Note:** At volume of change = ±12 dB Q = 1.

LM833-N MDC MWC DUAL AUDIO OPERATIONAL AMPLIFIER

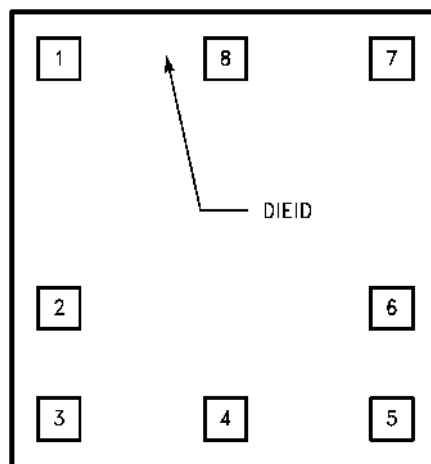

Figure 43. Die Layout (A - Step)



**PACKAGING INFORMATION**

Orderable Device	Status (1)	Package Type	Package Drawing	Pins	Package Qty	Eco Plan (2)	Lead/Ball Finish (6)	MSL Peak Temp (3)	Op Temp (°C)	Device Marking (4/5)	Samples
LM833M	ACTIVE	SOIC	D	8	95	TBD	Call TI	Call TI	-40 to 85	LM833 M	<a href="#">Samples</a>
LM833M/NOPB	ACTIVE	SOIC	D	8	95	Green (RoHS & no Sb/Br)	CU SN	Level-1-260C-UNLIM	-40 to 85	LM833 M	<a href="#">Samples</a>
LM833MM/NOPB	ACTIVE	VSSOP	DGK	8	1000	Green (RoHS & no Sb/Br)	CU SN	Level-1-260C-UNLIM	-40 to 85	Z83	<a href="#">Samples</a>
LM833MMX/NOPB	ACTIVE	VSSOP	DGK	8	3500	Green (RoHS & no Sb/Br)	CU SN	Level-1-260C-UNLIM	-40 to 85	Z83	<a href="#">Samples</a>
LM833MX/NOPB	ACTIVE	SOIC	D	8	2500	Green (RoHS & no Sb/Br)	CU SN	Level-1-260C-UNLIM	-40 to 85	LM833 M	<a href="#">Samples</a>
LM833N/NOPB	ACTIVE	PDIP	P	8	40	Green (RoHS & no Sb/Br)	CU SN   Call TI	Level-1-NA-UNLIM	-40 to 85	LM 833N	<a href="#">Samples</a>

(1) The marketing status values are defined as follows:

**ACTIVE:** Product device recommended for new designs.

**LIFEBUY:** TI has announced that the device will be discontinued, and a lifetime-buy period is in effect.

**NRND:** Not recommended for new designs. Device is in production to support existing customers, but TI does not recommend using this part in a new design.

**PREVIEW:** Device has been announced but is not in production. Samples may or may not be available.

**OBSELETE:** TI has discontinued the production of the device.

(2) Eco Plan - The planned eco-friendly classification: Pb-Free (RoHS), Pb-Free (RoHS Exempt), or Green (RoHS & no Sb/Br) - please check <http://www.ti.com/productcontent> for the latest availability information and additional product content details.

**TBD:** The Pb-Free/Green conversion plan has not been defined.

**Pb-Free (RoHS):** TI's terms "Lead-Free" or "Pb-Free" mean semiconductor products that are compatible with the current RoHS requirements for all 6 substances, including the requirement that lead not exceed 0.1% by weight in homogeneous materials. Where designed to be soldered at high temperatures, TI Pb-Free products are suitable for use in specified lead-free processes.

**Pb-Free (RoHS Exempt):** This component has a RoHS exemption for either 1) lead-based flip-chip solder bumps used between the die and package, or 2) lead-based die adhesive used between the die and leadframe. The component is otherwise considered Pb-Free (RoHS compatible) as defined above.

**Green (RoHS & no Sb/Br):** TI defines "Green" to mean Pb-Free (RoHS compatible), and free of Bromine (Br) and Antimony (Sb) based flame retardants (Br or Sb do not exceed 0.1% by weight in homogeneous material)

(3) MSL, Peak Temp. - The Moisture Sensitivity Level rating according to the JEDEC industry standard classifications, and peak solder temperature.

(4) There may be additional marking, which relates to the logo, the lot trace code information, or the environmental category on the device.

(5) Multiple Device Markings will be inside parentheses. Only one Device Marking contained in parentheses and separated by a "~" will appear on a device. If a line is indented then it is a continuation of the previous line and the two combined represent the entire Device Marking for that device.

<sup>(6)</sup> Lead/Ball Finish - Orderable Devices may have multiple material finish options. Finish options are separated by a vertical ruled line. Lead/Ball Finish values may wrap to two lines if the finish value exceeds the maximum column width.

**Important Information and Disclaimer:** The information provided on this page represents TI's knowledge and belief as of the date that it is provided. TI bases its knowledge and belief on information provided by third parties, and makes no representation or warranty as to the accuracy of such information. Efforts are underway to better integrate information from third parties. TI has taken and continues to take reasonable steps to provide representative and accurate information but may not have conducted destructive testing or chemical analysis on incoming materials and chemicals. TI and TI suppliers consider certain information to be proprietary, and thus CAS numbers and other limited information may not be available for release.

In no event shall TI's liability arising out of such information exceed the total purchase price of the TI part(s) at issue in this document sold by TI to Customer on an annual basis.

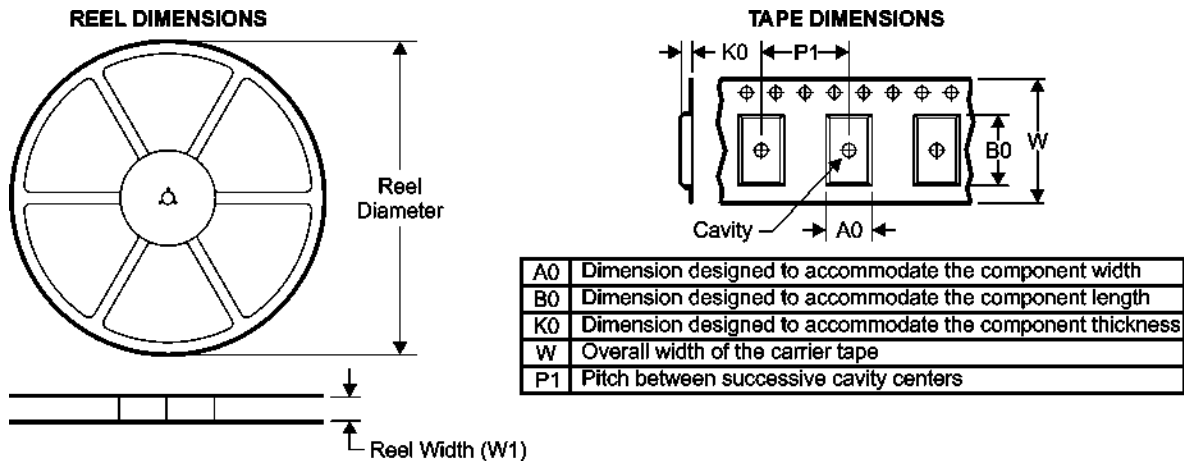
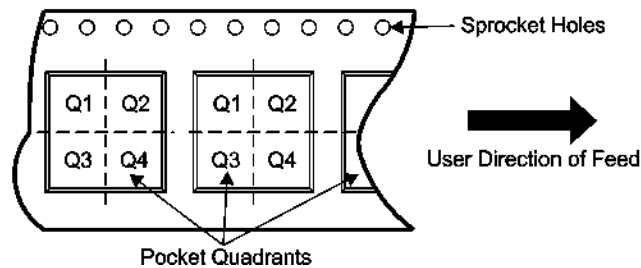
**TAPE AND REEL INFORMATION**

**QUADRANT ASSIGNMENTS FOR PIN 1 ORIENTATION IN TAPE**

\*All dimensions are nominal

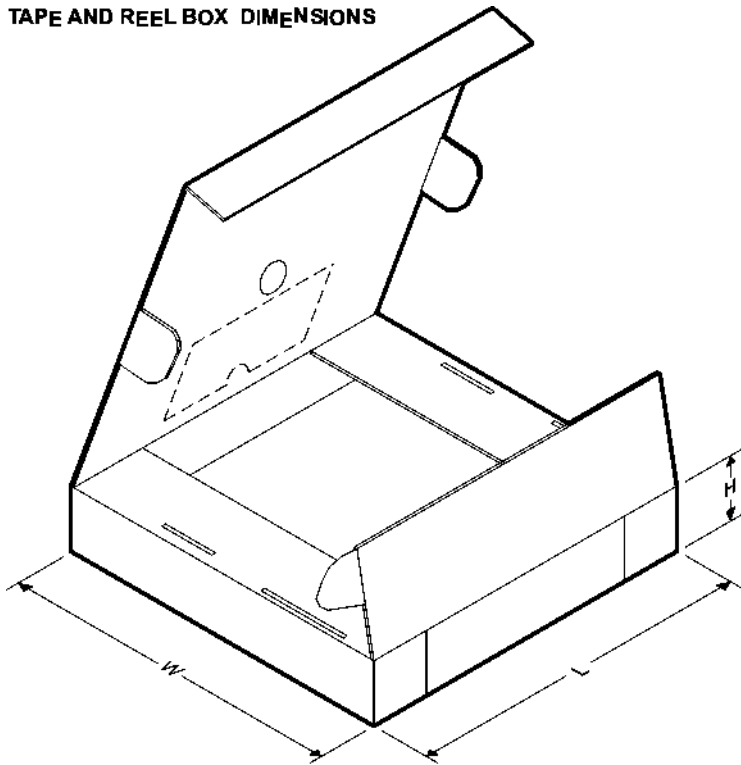
Device	Package Type	Package Drawing	Pins	SPQ	Reel Diameter (mm)	Reel Width W1 (mm)	A0 (mm)	B0 (mm)	K0 (mm)	P1 (mm)	W (mm)	Pin1 Quadrant
LM833MM/NOPB	VSSOP	DGK	8	1000	178.0	12.4	5.3	3.4	1.4	8.0	12.0	Q1
LM833MMX/NOPB	VSSOP	DGK	8	3500	330.0	12.4	5.3	3.4	1.4	8.0	12.0	Q1
LM833MX/NOPB	SOIC	D	8	2500	330.0	12.4	6.5	5.4	2.0	8.0	12.0	Q1

**TAPE AND REEL BOX DIMENSIONS**

\*All dimensions are nominal

Device	Package Type	Package Drawing	Pins	SPQ	Length (mm)	Width (mm)	Height (mm)
LM833MM/NOPB	VSSOP	DGK	8	1000	210.0	185.0	35.0
LM833MMX/NOPB	VSSOP	DGK	8	3500	367.0	367.0	35.0
LM833MX/NOPB	SOIC	D	8	2500	367.0	367.0	35.0

D (R-PDSO-G8)

PLASTIC SMALL OUTLINE



- NOTES:
- A. All linear dimensions are in inches (millimeters).
  - B. This drawing is subject to change without notice.
  - C. Body length does not include mold flash, protrusions, or gate burrs. Mold flash, protrusions, or gate burrs shall not exceed 0.006 (0,15) each side.
  - D. Body width does not include interlead flash. Interlead flash shall not exceed 0.017 (0,43) each side.
  - E. Reference JEDEC MS-012 variation AA.

P (R-PDIP-T8)

PLASTIC DUAL-IN-LINE PACKAGE



- NOTES:
- A. All linear dimensions are in inches (millimeters).
  - B. This drawing is subject to change without notice.
  - C. Falls within JEDEC MS-001 variation BA.

DGK (S-PDSO-G8)

PLASTIC SMALL-OUTLINE PACKAGE



- NOTES:
- A. All linear dimensions are in millimeters.
  - B. This drawing is subject to change without notice.
  - C. Body length does not include mold flash, protrusions, or gate burrs. Mold flash, protrusions, or gate burrs shall not exceed 0.15 per end.
  - D. Body width does not include interlead flash. Interlead flash shall not exceed 0.50 per side.
  - E. Falls within JEDEC MO-187 variation AA, except interlead flash.



- NOTES:
- A. All linear dimensions are in millimeters.
  - B. This drawing is subject to change without notice.
  - C. Publication IPC-7351 is recommended for alternate designs.
  - D. Laser cutting apertures with trapezoidal walls and also rounding corners will offer better paste release. Customers should contact their board assembly site for stencil design recommendations. Refer to IPC-7525 for other stencil recommendations.
  - E. Customers should contact their board fabrication site for solder mask tolerances between and around signal pads.



## IMPORTANT NOTICE FOR TI DESIGN INFORMATION AND RESOURCES

Texas Instruments Incorporated ("TI") technical, application or other design advice, services or information, including, but not limited to, reference designs and materials relating to evaluation modules, (collectively, "TI Resources") are intended to assist designers who are developing applications that incorporate TI products; by downloading, accessing or using any particular TI Resource in any way, you (individually or, if you are acting on behalf of a company, your company) agree to use it solely for this purpose and subject to the terms of this Notice.

TI's provision of TI Resources does not expand or otherwise alter TI's applicable published warranties or warranty disclaimers for TI products, and no additional obligations or liabilities arise from TI providing such TI Resources. TI reserves the right to make corrections, enhancements, improvements and other changes to its TI Resources.

You understand and agree that you remain responsible for using your independent analysis, evaluation and judgment in designing your applications and that you have full and exclusive responsibility to assure the safety of your applications and compliance of your applications (and of all TI products used in or for your applications) with all applicable regulations, laws and other applicable requirements. You represent that, with respect to your applications, you have all the necessary expertise to create and implement safeguards that (1) anticipate dangerous consequences of failures, (2) monitor failures and their consequences, and (3) lessen the likelihood of failures that might cause harm and take appropriate actions. You agree that prior to using or distributing any applications that include TI products, you will thoroughly test such applications and the functionality of such TI products as used in such applications. TI has not conducted any testing other than that specifically described in the published documentation for a particular TI Resource.

You are authorized to use, copy and modify any individual TI Resource only in connection with the development of applications that include the TI product(s) identified in such TI Resource. NO OTHER LICENSE, EXPRESS OR IMPLIED, BY ESTOPPEL OR OTHERWISE TO ANY OTHER TI INTELLECTUAL PROPERTY RIGHT, AND NO LICENSE TO ANY TECHNOLOGY OR INTELLECTUAL PROPERTY RIGHT OF TI OR ANY THIRD PARTY IS GRANTED HEREIN, including but not limited to any patent right, copyright, mask work right, or other intellectual property right relating to any combination, machine, or process in which TI products or services are used. Information regarding or referencing third-party products or services does not constitute a license to use such products or services, or a warranty or endorsement thereof. Use of TI Resources may require a license from a third party under the patents or other intellectual property of the third party, or a license from TI under the patents or other intellectual property of TI.

TI RESOURCES ARE PROVIDED "AS IS" AND WITH ALL FAULTS. TI DISCLAIMS ALL OTHER WARRANTIES OR REPRESENTATIONS, EXPRESS OR IMPLIED, REGARDING TI RESOURCES OR USE THEREOF, INCLUDING BUT NOT LIMITED TO ACCURACY OR COMPLETENESS, TITLE, ANY EPIDEMIC FAILURE WARRANTY AND ANY IMPLIED WARRANTIES OF MERCHANTABILITY, FITNESS FOR A PARTICULAR PURPOSE, AND NON-INFRINGEMENT OF ANY THIRD PARTY INTELLECTUAL PROPERTY RIGHTS.

TI SHALL NOT BE LIABLE FOR AND SHALL NOT DEFEND OR INDEMNIFY YOU AGAINST ANY CLAIM, INCLUDING BUT NOT LIMITED TO ANY INFRINGEMENT CLAIM THAT RELATES TO OR IS BASED ON ANY COMBINATION OF PRODUCTS EVEN IF DESCRIBED IN TI RESOURCES OR OTHERWISE. IN NO EVENT SHALL TI BE LIABLE FOR ANY ACTUAL, DIRECT, SPECIAL, COLLATERAL, INDIRECT, PUNITIVE, INCIDENTAL, CONSEQUENTIAL OR EXEMPLARY DAMAGES IN CONNECTION WITH OR ARISING OUT OF TI RESOURCES OR USE THEREOF, AND REGARDLESS OF WHETHER TI HAS BEEN ADVISED OF THE POSSIBILITY OF SUCH DAMAGES.

You agree to fully indemnify TI and its representatives against any damages, costs, losses, and/or liabilities arising out of your non-compliance with the terms and provisions of this Notice.

This Notice applies to TI Resources. Additional terms apply to the use and purchase of certain types of materials, TI products and services. These include; without limitation, TI's standard terms for semiconductor products (<http://www.ti.com/sc/docs/stdterms.htm>), [evaluation modules](#), and [samples](http://www.ti.com/sc/docs/sampterm.htm) (<http://www.ti.com/sc/docs/sampterm.htm>).

Mailing Address: Texas Instruments, Post Office Box 655303, Dallas, Texas 75265  
Copyright © 2017, Texas Instruments Incorporated