

# O5H501

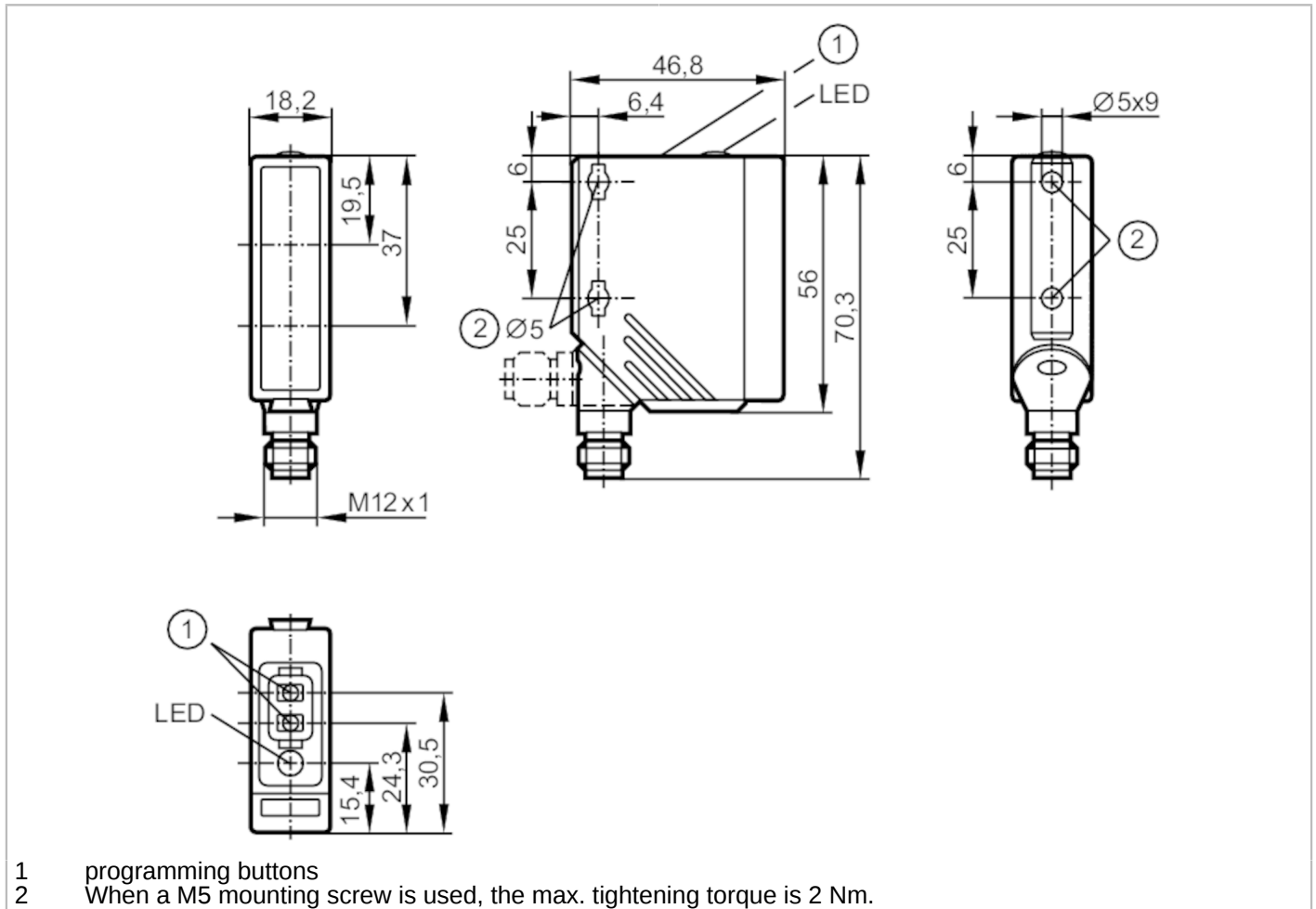

## Diffuse reflection sensor with background suppression

O5H-FPKG/US100



Product characteristics	
Type of light	red light
Housing	rectangular
Dimensions [mm]	56 x 18.2 x 46.8
Application	
Special feature	Background suppression
Function principle	Diffuse reflection sensor
Electrical data	
Operating voltage [V]	10...36 DC; ("supply class 2" to cULus)
Current consumption [mA]	30
Protection class	II
Reverse polarity protection	yes
Type of light	red light
Wave length [nm]	624

# O5H501



## Diffuse reflection sensor with background suppression

O5H-FPKG/US100

Outputs		
Electrical design		PNP
Output function		light-on/dark-on mode; (programmable)
Max. voltage drop switching output DC	[V]	2.5
Permanent current rating of switching output DC	[mA]	200
Switching frequency DC	[Hz]	1000
Short-circuit protection		yes
Type of short-circuit protection		pulsed
Overload protection		yes
Detection zone		
Range	[mm]	60...700; (white paper 200 x 200 mm 90% remission)
Range on white object (90 % remission)	[mm]	60...700
Range on grey object (18 % remission)	[mm]	60...370
Range on black object (6 % remission)	[mm]	60...210
Range adjustable		yes
Max. light spot diameter	[mm]	35
Light spot dimensions refer to		at maximum range
Background suppression available		yes
Operating conditions		
Ambient temperature	[°C]	-25...60
Protection		IP 67
Tests / approvals		
EMC		EN 60947-5-2
MTTF	[years]	360
Mechanical data		
Weight	[g]	67.5
Housing		rectangular
Dimensions	[mm]	56 x 18.2 x 46.8
Materials		housing: PA; bezel: stainless steel; operator interface: TPU
Lens material		PMMA
Lens alignment		side lens
Displays / operating elements		
Display	switching status	1 x LED, yellow
Teach function		yes
Electronic lock		yes
Remarks		
Pack quantity		1 pcs.
Electrical connection		
Connector: 1 x M12		

# O5H501



## Diffuse reflection sensor with background suppression

O5H-FPKG/US100



### Connection

