

U.I. Lapp GmbH	<h1>DATASHEET</h1>	
	EPIC® H-B 10 TSB	79057700 14.11.2013

Housing design H-B. The industry standard.
The smallest housing with single and double lever. The right housing is available for every application



Automation



Industrial machinery and plant engineering



Mechanical resistance



Robust



Waterproof

Info

Universal, robust metal housings size H-B 10

Application range

Plant engineering
Light & sound technology
Plastics industry

Product features

Hood, low version
Dual levers
Side cable entry
Versions with neck

Remark

Photographs are not to scale and do not represent detailed images of the respective products.

Technical Data

Article:	H-B 10 TSB M25
M:	25
Neck:	yes
Pieces / PU:	10
Material:	Housing: powder-coated aluminium alloy, grey Lever: zinc-plated steel Sealing: NBR
Protection rating:	IP 65 (latched)
Temperature range:	-40 °C to +100 °C, short-term up to +125 °C

Product Management	Document: EPIC® H-B 10 TSB	1 / 2
--------------------	----------------------------	-------

U.I. Lapp GmbH	<h1>DATASHEET</h1>	
	EPIC® H-B 10 TSB	79057700 14.11.2013

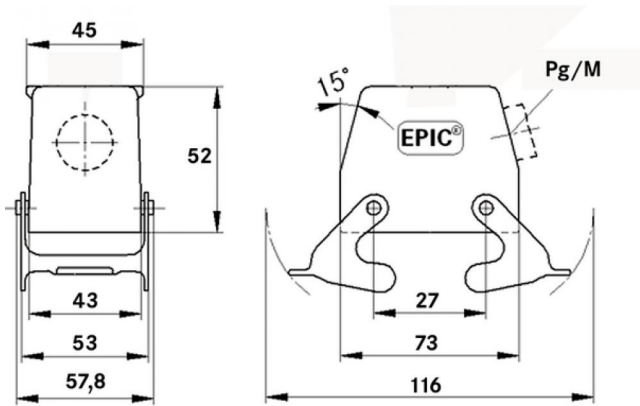

Product Management	Document: EPIC® H-B 10 TSB	2 / 2
--------------------	----------------------------	-------