

I15005

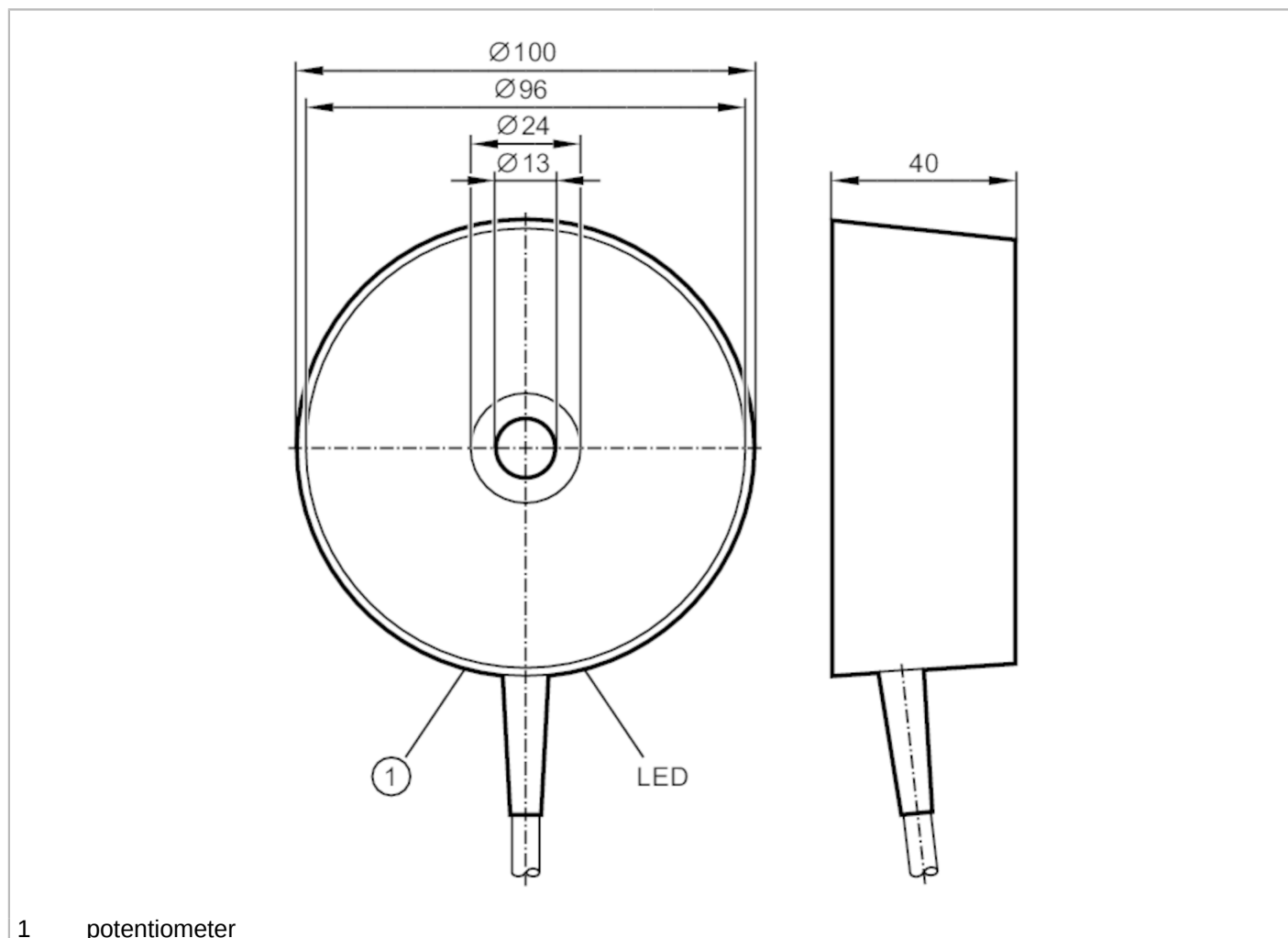

Inductive area sensor

SIT-4070-CPKG/2M



1 potentiometer



Product characteristics

Electrical design		PNP
Output function		complementary
Sensing range	[mm]	20...70
Housing		cylindrical
Dimensions	[mm]	Ø 100

Electrical data

Operating voltage	[V]	10...36 DC
Current consumption	[mA]	20; (24 V)
Protection class		II
Reverse polarity protection		yes

I15005



Inductive area sensor

SIT-4070-CPKG/2M

Outputs		
Electrical design		PNP
Output function		complementary
Max. voltage drop switching output DC	[V]	3.5
Permanent current rating of switching output DC	[mA]	250
Switching frequency DC	[Hz]	5
Short-circuit protection		yes
Type of short-circuit protection		pulsed
Overload protection		yes
Detection zone		
Sensing range	[mm]	20...70
Sensing range adjustable		yes
Factory setting sensing range	[mm]	70
Real sensing range Sr	[mm]	70 ± 10 %
Accuracy / deviations		
Correction factor		steel: 1 / stainless steel: 0.7 / brass: 0.4 / aluminium: 0.4 / copper: 0.3
Hysteresis	[% of Sr]	< 15
Switch point drift	[% of Sr]	-15...15
Operating conditions		
Ambient temperature	[°C]	-20...70
Protection		IP 65
Tests / approvals		
EMC	EN 60947-5-2	
	EN 55011	class B
Mechanical data		
Weight	[g]	508.5
Housing		cylindrical
Mounting		non-flush mountable
Dimensions	[mm]	Ø 100
Materials		PBT
Displays / operating elements		
Display	switching status	1 x LED, yellow
Accessories		
Accessories (supplied)		screws: 1 x M10 x 50
		covers: 1
Remarks		
Pack quantity		1 pcs.

I15005



Inductive area sensor

SIT-4070-CPKG/2M

Electrical connection

Cable: 2 m, PVC; 4 x 0.34 mm²

Connection

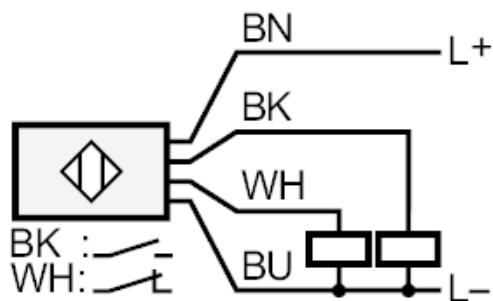

Core colours :

BK =	black
BN =	brown
BU =	blue
WH =	white