



**Part no.: 424421**  
**BT-SB10**  
**Mounting bracket**

Figure can vary

## Contents

- Technical data
- Dimensioned drawings

Part no.: 424421 – BT-SB10 – Mounting bracket

## Technical data

### Basic data

Suitable for	CML700i light curtains CSL 710 light curtains MLC 500, MLC 300 safety light curtains MLD 500, MLD 300 multiple light beam safety devices Single light beam safety devices MLD500
--------------	--

### Mechanical data

Design of mounting device	Mounting clamp
Type of fastening, at system	Through-hole mounting
Type of fastening, at device	Clampable
Type of mounting device	Swiveling
Swivel range	-8 ... 8 °
Mounting device material	Metal

### Classification

Customs tariff number	73182900
eCl@ss 8.0	27279202
eCl@ss 9.0	27273701
ETIM 5.0	EC003015
ETIM 6.0	EC003015

## Dimensioned drawings

All dimensions in millimeters

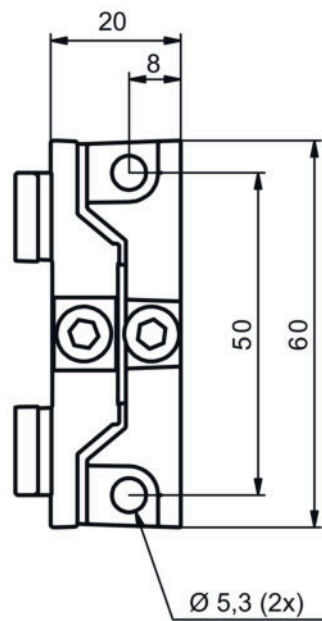
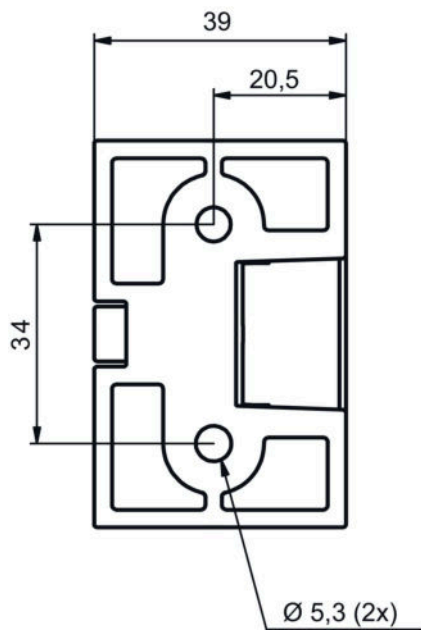
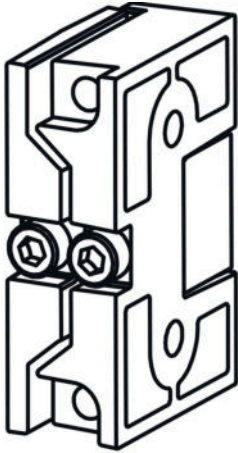

Mounting variants

