

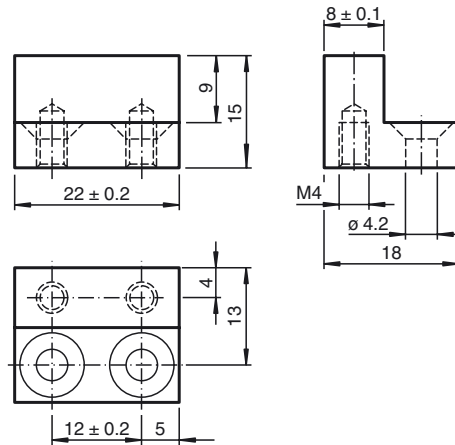

Dimensions



Technical data

Mechanical specifications

| | |
|----------|---------------------|
| Material | Steel ST37 / 1.0037 |
| Mass | 20 g |

Model Number

BT-F90-G

Damping element for F90 sensors; front screw holes

Release date: 2012-03-21 10:34 Date of issue: 2012-03-21 184702_eng.xml