

 **GOYEN**

# PILOT VALVE ENCLOSURES FOR HAZARDOUS LOCATIONS

# PILOT VALVE ENCLOSURES FOR HAZARDOUS LOCATIONS

## 3-6VFD COMBINATION FLAME AND DUST IGNITION PROOF ENCLOSURES

Goyen pilot valve enclosures for hazardous locations are available in a combination of flame proof and dust ignition proof assemblies, where 4, 5 and 6 pilot valves are available. The 3-6VFD can be supplied with combined international approvals: Canadian CSA/Underwriters Laboratory UL or European ATEX/International IECEx.

In addition, in Canada and Europe, Goyen offers enclosures that are certified for use in flame proof and dust ignition proof applications. This has the advantage of simplifying assembly designs when using the Goyen enclosures.

### Construction

**Body:** Diecast Aluminium AS313, LM24, A380

The ATEX/IECEx enclosure is available with optional electroless nickel plating, or optional E-coat when there is no heater fitted.

**Ferrule:** AISI 302 SS

**Armature:** 430FR SS

**Seals:** Nitrile

**Screws:** AISI 302 SS

### Operation

**Recommended on time:** 50–150 ms

**On time range:** 50–500 ms

**Recommended time between pulses:** 1 minute or more, if maximum on time is used.

### Pilot Performance

**Flow:** 0.27 Kv/0.32 Cv

**Maximum Working Pressure:**

800 kPa/116 psi

**Minimum Working Pressure:** 0 kPa/0 psi

## Solenoid Performance

VOLTAGE	INRUSH CURRENT MA	HOLD CURRENT MA	POWER
220/240 50/60 Hz	148/143	105/94	23.1 V A
100/120 50/60 Hz	234/255	180/152	19.8 V A
24 V DC	873	873	20 W
24 V AC	1338	963	13 W
110V DC	212	212	24 W

### Ambient Temperature Range:

ATEX/IECEx: –20°C to +40°C  
(–4°F to +104°F)

CSA/UL: –25°C to +40°C  
(–13°F to +104°F)

**Fluid Media:** Air or inert gas at 25°C

### Certification

**CSA/UL:** NEC500 Div 1, NEC505 Zone 1 and NEC506 Zone 21

**ATEX/IECEx:** II Category 2G, II Category 2D

**IP Rating:** IP66

### RESTRICTIONS

This product's hazardous areas certifications are valid only for product that has not been modified since leaving the factory. Modifications made to the enclosure such as the fitment of additional seals, the addition or removal of pilot valves and coils, changes in markings, or physical modifications made to the enclosure itself will invalidate the product certifications. Only activities described in 'Installation' and 'Maintenance' may be conducted without affecting the certification of the product.

### MAINTENANCE

Annual maintenance of serviceable parts is recommended. Serviceable

items are the pilot armature, armature spring, pilot valve body o-ring. The same model Goyen coil may also replace damaged coils. All other items are non-serviceable. Goyen recommend that appropriately qualified personnel conduct all maintenance activities. Certification of maintenance staff and facilities may be required under some certification schemes. Inappropriate service invalidates the product certifications.

## PRODUCT WARNING LABELS

### 3-6VFD Series

#### CSA/UL

CAUTION: open circuit and allow 5 minutes after heater is de-energised before removing cover. Keep tightly closed when in operation  
WARNING: more than one live circuit. See diagram.

#### ATEX/IECEx

Warning do not open whilst energised, do not open when explosive atmosphere is present. Use cables rated at 135°C when anti-condensation heater is installed.

Where optional E-coat is applied to the enclosure: warning – Electrostatic hazard, clean only with damp cloth.

# PILOT VALVE ENCLOSURES FOR HAZARDOUS LOCATIONS

## GUIDE TO HAZARDOUS AREAS APPLICATION WITHIN DUST COLLECTORS

### Example zones around a dust collector

The following examples assume that the particulate being collected is a combustible dust.

Note that the responsibility for correctly assessing the hazardous zones around the dust collection equipment remains with the plant operator.

In the event of a filter breakage, dust will enter the clean side of the dust collector. The migration of dust may be in sufficient concentration to present a dust explosion risk.

Where there are no dust monitors in place on the clean side of the dust

collector, a broken bag condition may exist for more than 10 hours before rectification. Therefore the clean side is classed as Zone 1 (NEC505) or Zone 21 (Atex).

Goyen supplies AtexII 3G/D dust monitors to raise an alarm in the case of a filter break. In this case the clean air plenum is classified as Zone 2 if the system will be rectified within 10 hours.

The area surrounding the dust collector housing may be classified as Zone 2. If there is adequate ventilation around the dust collector the Zone 2 classification may be eliminated. The area around the dust collection point is usually classified as Zone 1.

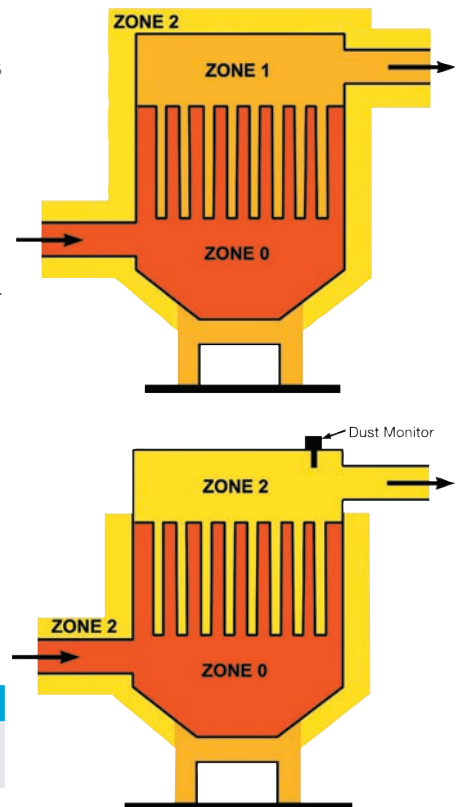

## COMPARING AREA CLASSIFICATION SCHEMES

NORTH AMERICA		EUROPE (ATEX SCHEME)			
NEC500 Divisions	NEC505 & 506 CEC Zones	Gas Zones	Dust Zones	Equipment Category*	Group**
1	0	0	20	1	II
	1	1	21	2	II
2	2	2	22	3	II

\* Under the ATEX scheme equipment categories for use in gas environments are denoted by a 'G' suffix, and equipment categories for dust environments are denoted by a 'D' suffix. Examples: Equipment category 2G is suitable for use in ATEX zone 1 areas. Equipment category 2D is suitable for use in ATEX zone 21 areas.

\*\* Only Group II zones are shown. Group I zones are relevant to mining applications only.

### Hazardous zone definitions

DIVISION	ZONE	HAZARDOUS AREA CHARACTERISTIC
1	0 or 20	Hazardous condition is present continuously, for long periods, or frequently (more than 1000 hours per year)
	1 or 21	Hazardous condition is likely to occur in normal operation occasionally (between 10 and 1000 hours per year)
2	2 or 22	Hazardous condition is unlikely to occur in normal operation, or infrequently and for short periods (less than 10 hours per year)

# PILOT VALVE ENCLOSURES FOR HAZARDOUS LOCATIONS



## 3-6VFD SERIES COMBINATION FLAME AND EXPLOSION PROOF PILOT VALVE ENCLOSURE

Diecast aluminium enclosure with explosion proof and flame proof (Ex-d) protection suitable for use in hazardous areas, available optionally with anti-condensation heater.

### SUITABLE FOR

NEC500 Division 1, NEC505 Zone 1, NEC506 Zone 21 and ATEX/IECEX Zone 21 (II Cat 2G and 2D equipment) hazardous environments, for piloting Goyen diaphragm valves.

### SPARE PARTS

K0383 Single armature kit. Includes, spring, armature, and o-ring.

G604718 DP Seal

## 3-6VFD PRODUCT CERTIFICATIONS

WITH HEATER KIT FITTED	WITHOUT HEATER KIT FITTED
<b>CSA</b>	
LR26709	LR26709
Class I, Group D	Class I, Group D
Class II Groups E, F, G	Class II Groups E, F, G
Temp Code T2C	Temp Code T4
<b>UL</b>	
Listed 823N	Listed 823N
Class I, Group D	Class I, Group D
Nema 7	Nema 7
Class II Groups E, F, G	Class II Groups E, F, G
Nema 9	Nema 9
Temp Code T3C	Temp Code T3C
<b>IECEX</b>	
Ex d IIB T3 Gb	Ex d IIB T6 Gb
Ex tb IIIC T192°C Db IP6X	Ex tb IIIC T85°C Db IP6X
IECEX SIR 08.0045X	IECEX SIR 08.0045X
<b>ATEX</b>	
II 2 G D	II 2 G D
Ex d IIB T3 Gb	Ex d IIB T6 Gb
Ex tb IIIC T192°C Db IP6X	Ex tb IIIC T85°C Db IP6X
SIRA 02ATEX1408X	SIRA 02ATEX1408X

## HOW TO ORDER

**3-6VFD - 4 - 0 - 1 - 0 - C - B - 0**

### Number of pilots fitted

4  
5  
6

### Thread type

(Pilot Thread/Enclosure Conduit Thread)  
0=NPT/NPT  
1=RP/M  
3=NPT/M  
4=RP/G

### Name plate

1=Goyen  
0=none

### Solenoid type

QT2 solenoid order code, drop the 'K-'  
*Refer to Q Series Solenoid product specification.*

### Surface protection type

Blank=Natural  
N=ENP (Electroless Nickel Plated), for ATEX/IECEX enclosures  
E=E-coat, for ATEX/IECEX enclosures without heaters

### Approval type

C=CSA/UL  
A=ATEX/IEC Ex

### Heater type

0=none  
5=24V DC  
6=100/120V AC  
7=240V AC

## CSA/UL RATED ENCLOSURES

PART NO.	NO. OF VALVES	THREAD SIZES	GOYEN NAMEPLATE	HEATER TYPE	COIL VOLTAGE
3-6VFD4000C-330	4	1/8-3/4 NPT	No	No	220/240 V AC
3-6VFD4000C-331	4	1/8-3/4 NPT	No	No	100/120 V AC
3-6VFD4000C-336	4	1/8-3/4 NPT	No	No	24 V DC
3-6VFD5000C-330	5	1/8-3/4 NPT	No	No	220/240 V AC
3-6VFD5000C-331	5	1/8-3/4 NPT	No	No	100/120 V AC
3-6VFD5000C-336	5	1/8-3/4 NPT	No	No	24 V DC
3-6VFD6000C-330	6	1/8-3/4 NPT	No	No	220/240 V AC
3-6VFD6000C-331	6	1/8-3/4 NPT	No	No	100/120 V AC
3-6VFD6000C-336	6	1/8-3/4 NPT	No	No	24 V DC
3-6VFD4007C-330	4	1/8-3/4 NPT	No	220/240 V AC	220/240 V AC
3-6VFD4006C-331	4	1/8-3/4 NPT	No	100/120 V AC	100/120 V AC
3-6VFD4005C-336	4	1/8-3/4 NPT	No	24 V DC	24 V DC
3-6VFD5007C-330	5	1/8-3/4 NPT	No	220/240 V AC	220/240 V AC
3-6VFD5006C-331	5	1/8-3/4 NPT	No	100/120 V AC	100/120 V AC
3-6VFD5005C-336	5	1/8-3/4 NPT	No	24 V DC	24 V DC
3-6VFD6007C-330	6	1/8-3/4 NPT	No	220/240 V AC	220/240 V AC
3-6VFD6006C-331	6	1/8-3/4 NPT	No	100/120 V AC	100/120 V AC
3-6VFD6005C-336	6	1/8-3/4 NPT	No	24 V DC	24 V DC

## ATEX/IECEx RATED ENCLOSURES

PART NO.	NO. OF VALVES	THREAD SIZES	GOYEN NAMEPLATE	HEATER TYPE	COIL VOLTAGE
3-6VFD4110A-331	4	1/8RP-M25	Yes	No	100/120 V AC
3-6VFD4110A-330	4	1/8RP-M25	Yes	No	220/240 V AC
3-6VFD4110A-332	4	1/8RP-M25	Yes	No	24 V AC
3-6VFD4110A-334	4	1/8RP-M25	Yes	No	110 V DC
3-6VFD4110A-336	4	1/8RP-M25	Yes	No	24 V DC
3-6VFD5110A-331	5	1/8RP-M25	Yes	No	100/120 V AC
3-6VFD5110A-334	5	1/8RP-M25	Yes	No	110 V DC
3-6VFD5110A-336	5	1/8RP-M25	Yes	No	24 V DC
3-6VFD6110A-331	6	1/8RP-M25	Yes	No	100/120 V AC
3-6VFD6110A-330	6	1/8RP-M25	Yes	No	220/240 V AC
3-6VFD6110A-336	6	1/8RP-M25	Yes	No	24 V DC
3-6VFD5115A-336	5	1/8RP-M25	Yes	24 V DC	24 V DC
3-6VFD5117A-330	5	1/8RP-M25	Yes	220/240 V AC	220/240 V AC
3-6VFD5110A-332	5	1/8RP-M25	Yes	No	24 V AC
3-6VFD4100A-331	4	1/8RP-M25	No	No	100/120 V AC
3-6VFD4100A-336	4	1/8RP-M25	No	No	24 V DC
3-6VFD6117A-330	6	1/8RP-M25	Yes	220/240 V AC	220/240 V AC
3-6VFD6110A-332	6	1/8RP-M25	Yes	No	24 VAC
3-6VFD6100A-330	6	1/8RP-M25	No	No	220/240 VAC
3-6VFD4100A-330	4	1/8RP-M25	No	No	220/240 VAC
3-6VFD5100A-331	5	1/8RP-M25	No	No	100/120 VAC
3-6VFD5100A-336	5	1/8RP-M25	No	No	24 VDC
3-6VFD5100A-330	5	1/8RP-M25	No	No	220/240 VAC
3-6VFD6100A-331	6	1/8RP-M25	No	No	100/120 VAC
3-6VFD6100A-336	6	1/8RP-M25	No	No	24 V DC
3-6VFD6116A-331	6	1/8RP-M25	Yes	100/120 V AC	100/120 V AC
3-6VFD6115A-336	6	1/8RP-M25	Yes	24 V DC	24 V DC
3-6VFD5017A-330	5	1/8-3/4 NPT	Yes	220/240 V AC	220/240 V AC

# PILOT VALVE ENCLOSURES FOR HAZARDOUS LOCATIONS

## 3-6VFD DIMENSIONS AND WEIGHTS [IN MM AND (INCHES)]

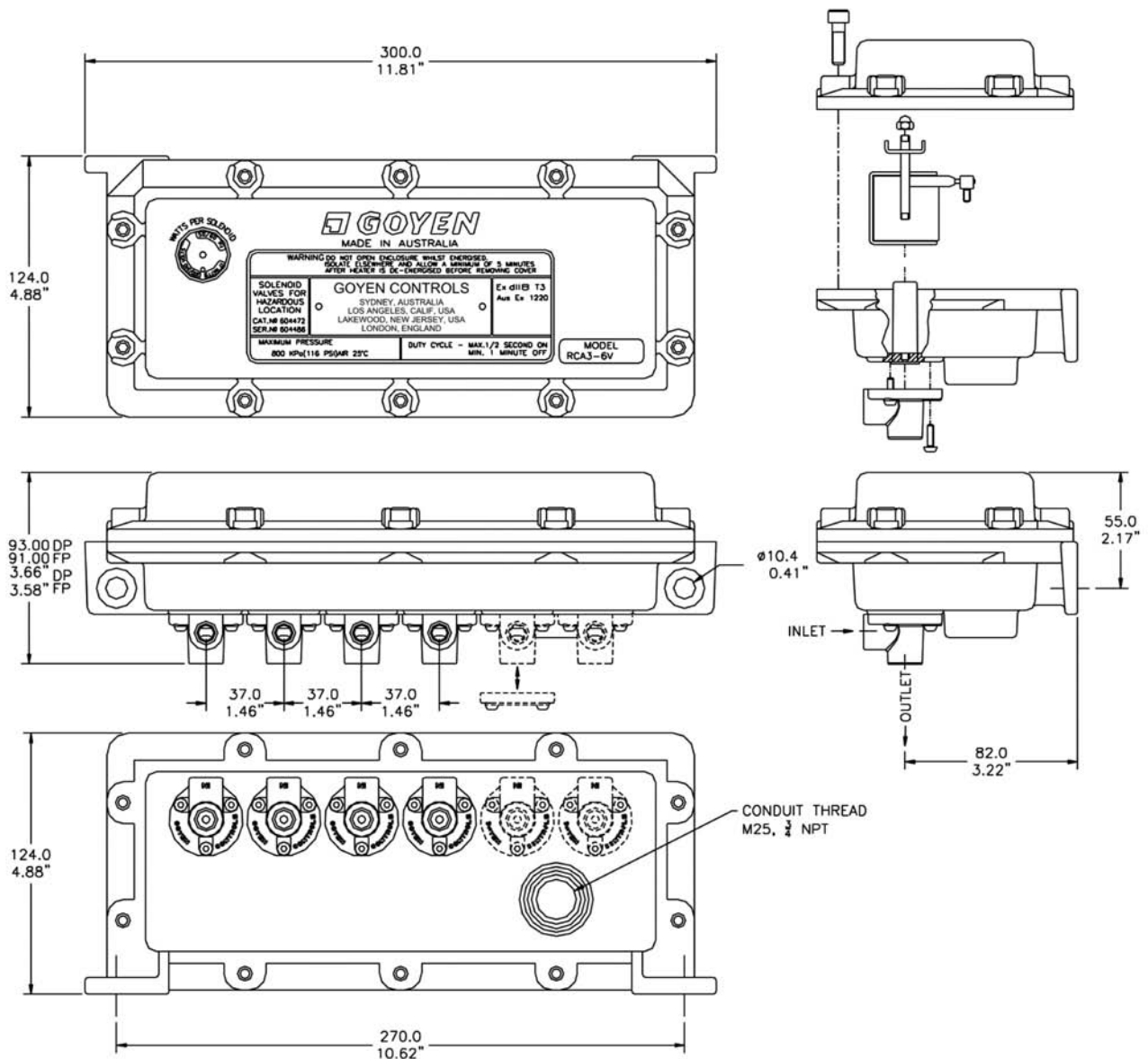

## WEIGHTS

### 3-6VFD Series

Mass = 2.21 kg + 0.08 kg per fitted pilot  
(4.87 lbs + 0.18 lbs per fitted pilot)

# PILOT VALVE ENCLOSURES FOR HAZARDOUS LOCATIONS

## INSTALLATION

**WARNING:** Ensure that power is isolated from the system prior to installing or opening this product. Where a heater kit is installed, ensure that the heater has been de-energised for a minimum of 5 minutes prior to opening the enclosure. Ensure that the enclosure is properly assembled with all flange screws fully tightened (minimum 10 Nm [7.4 ft.lbs]) prior to applying power in a hazardous area.

### Mounting

Enclosures should be mounted in a horizontal position, where the pilot valves and solenoid assemblies are in the preferred vertical orientation.

### Threads

Pilot valve inlet and exhaust outlets are offered in both 1/8" BSPP (Rp) and NPT. The enclosure base has one conduit entry with either M25 or 3/4" NPT thread.

### Electrical connections

Refer to diagram below. The included Goyen QT2 solenoids are provided with screw/spade terminals. These solenoids are neutrally linked at the factory for customer convenience.

The internal grounding terminal must be used for equipment grounding.

### Pneumatic connections

These pilot valves are connected to the dust collector reverse pulse jet valves using metric 4 mm tubing (ID 0.157") or imperial 1/4" tubing (ID 0.162") and maximum length of 1.5 m (4.9 ft).

### ANTI-CONDENSATION HEATER ELEMENTS

Enclosures can be factory fitted with a heater element to assist in the prevention of condensation within the enclosure.

Using separate power supply wiring, the choice of heater voltage can be used with any coil voltage.

Refer to the How To Order code.

### HEATER RATINGS

VOLTAGE	WATTS
24 V DC	48
110/120 V AC	100
220/240 V AC	100

### HEATER INSTALLATION

- (1) Heater retaining clip
- (2) Heater element
- (3) Wiring terminal block
- (4) Thermostat element

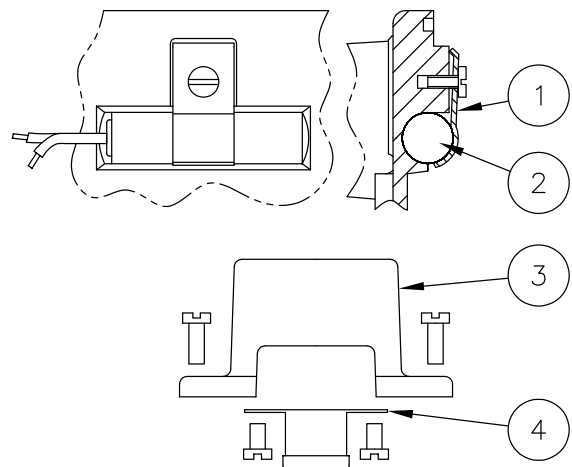

### Heater terminal block connections

