

High Voltage Boost Charge Pump

FEATURES

- Wide Input Range: 4.5V to 55V V_{IN}/V_{AUX}
- Reverse Input Protection to $-55V$
- Split Input Supplies for High Efficiency Boost Ratios
- I_{OUT} Up to 50mA
- 15 μA V_{IN} Quiescent Current
- 1 μA V_{AUX} Quiescent Current
- Stable with Ceramic Capacitors
- Short-Circuit/Thermal Protection
- Thermally Enhanced 10-Pin MSOP Package
- AECQ-100 Qualified for Automotive Applications

APPLICATIONS

- High Efficiency General Purpose High Voltage Boost Supplies
- High Side N-FET Driver
- Industrial/Automotive Power Switching
- V_{IN} Tracking Supply

DESCRIPTION

The LTC3290 is a high voltage boost charge pump with a wide 4.5V to 55V input voltage range that can deliver up to 50mA of output current.

When the V_{SET} pin is grounded, the LTC3290 operates as a standard boost charge pump, boosting the V_{OUT} output to a maximum of the sum of the V_{IN} and V_{AUX} input supplies. An external resistor divider can be used on the V_{OUT} , FB and GND pins to set the output voltage to any value between 1V and $V_{IN} + V_{AUX}$ with hysteretic Burst Mode operation.

Alternatively, the device can be configured in a V_{IN} tracking mode, in which the V_{OUT} pin regulates at a fixed offset above the V_{IN} pin. The offset voltage is programmed with external resistors, one from the V_{OUT} to the V_{SET} pin and the other from the FB pin to GND. The maximum output voltage is limited to $V_{IN} + V_{AUX}$.

The LTC3290 is available in a thermally enhanced 10-pin MSOP package.

All registered trademarks and trademarks are the property of their respective owners.

TYPICAL APPLICATION

15V Output from a 12V Input (with 5V Auxiliary Input)
Standard Boost Charge Pump Mode, $V_{SET} = 0V$

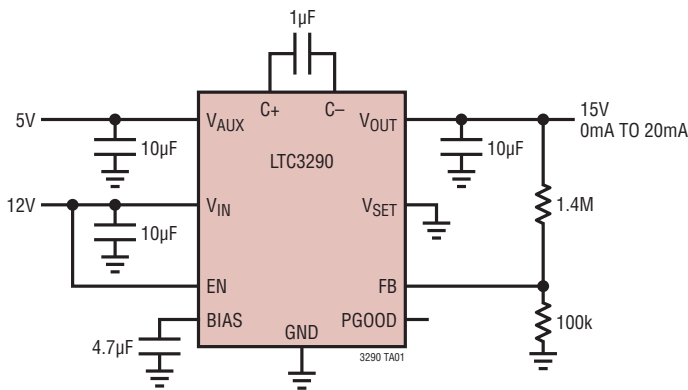

Efficiency vs Output Current

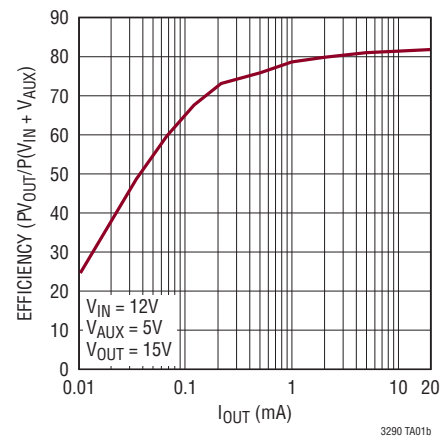

ABSOLUTE MAXIMUM RATINGS

(Notes 1, 3)

V_{IN} , EN, V_{AUX}	-60V to 60V
V_{IN} to V_{AUX} , V_{IN} to EN	60V
V_{OUT} , V_{SET}	-0.3V to 60V
FB, PGOOD	-0.3V to BIAS + 0.3V
BIAS	-0.3V to 6V
V_{OUT} Short-Circuit Duration	Indefinite
Operating Junction Temperature Range (Notes 2, 3)	-55°C to 150°C
Storage Temperature Range	-65°C to 150°C
Lead Temperature (Soldering, 10 sec)	300°C

PIN CONFIGURATION

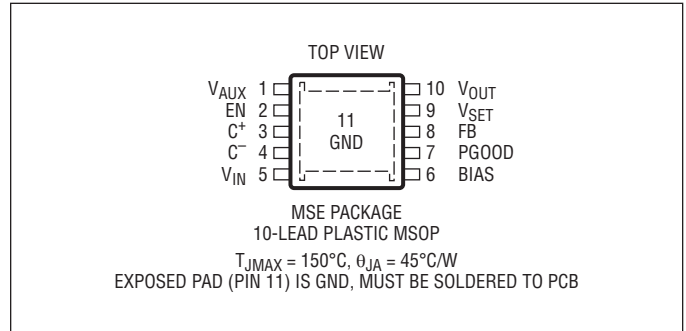

ORDER INFORMATION

LEAD FREE FINISH	TAPE AND REEL	PART MARKING*	PACKAGE DESCRIPTION	TEMPERATURE RANGE
LTC3290EMSE#PBF	LTC3290EMSE#TRPBF	LTGZW	10-Lead Plastic MSOP	-40°C to 125°C
LTC3290IMSE#PBF	LTC3290IMSE#TRPBF	LTGZW	10-Lead Plastic MSOP	-40°C to 125°C
LTC3290HMSE#PBF	LTC3290HMSE#TRPBF	LTGZW	10-Lead Plastic MSOP	-40°C to 150°C
LTC3290MPMSE#PBF	LTC3290MPMSE#TRPBF	LTGZW	10-Lead Plastic MSOP	-55°C to 150°C

AUTOMOTIVE PRODUCTS**

LTC3290HMSE#WPBF	LTC3290HMSE#WTRPBF	LTGZW	10-Lead Plastic MSOP	-40°C to 150°C
------------------	--------------------	-------	----------------------	----------------

Contact the factory for parts specified with wider operating temperature ranges. *The temperature grade is identified by a label on the shipping container.

Tape and reel specifications. Some packages are available in 500 unit reels through designated sales channels with #TRMPBF suffix.

**Versions of this part are available with controlled manufacturing to support the quality and reliability requirements of automotive applications. These models are designated with a #W suffix. Only the automotive grade products shown are available for use in automotive applications. Contact your local Analog Devices account representative for specific product ordering information and to obtain the specific Automotive Reliability reports for these models.

ELECTRICAL CHARACTERISTICS

The ● denotes the specifications which apply over the specified operating junction temperature range, otherwise specifications are at $T_A = 25^\circ\text{C}$ (Note 2), $V_{IN} = EN = 12\text{V}$, $V_{AUX} = 5\text{V}$.

SYMBOL	PARAMETER	CONDITIONS	MIN	TYP	MAX	UNITS
Boost Charge Pump						
V_{IN}	Input Supply Voltage Range		● 4.5		55	V
V_{AUX}	Auxiliary Supply Voltage Range		● 4.5		55	V
$(V_{IN} + V_{AUX})$	Sum of Input Supply Voltages		● 9		55	V
$(V_{IN} + V_{AUX})_{OV}$	Input Overvoltage Rising Threshold Hysteresis	$(V_{IN} + V_{AUX})$ Rising, $V_{SET} = \text{Hig}$ (Note 4)		63 65 4	67	V V
V_{OUT_OV}	Output Overvoltage Rising Threshold Hysteresis	V_{OUT} Rising (Note 4)		63 65 4	67	V V
I_{VIN}	V_{IN} Quiescent Current	Shutdown, $EN = 0\text{V}$ $I_{VOUT} = 0\text{mA}$		3 15	5 30	μA μA
I_{VAUX}	V_{AUX} Quiescent Current	Shutdown, $EN = 0\text{V}$ $I_{VOUT} = 0\text{mA}$		1 1	3 3	μA μA
V_{FB}	FB Regulation Voltage		● 0.98	1	1.02	V
R_{OL}	Effective Open Loop Output Resistance			65		Ω
I_{CL_VOUT}	V_{OUT} Current Limit	V_{OUT} Not in Regulation (Note 5)	● 100	150	200	mA
V_{ENH}	Enable Pin Threshold Rising		●	1.1	2	V
V_{ENL}	Enable Pin Threshold Falling		● 0.4	1		V
V_{SETH}	V_{SET} Pin Threshold Rising		●	1.1	2	V
V_{SETL}	V_{SET} Pin Threshold Falling		● 0.4	1		V
I_{EN}	Enable Pin Leakage Current			-1	0	1 μA
$V_{PG_RISE_BST}$	PGOOD Pin Threshold Rising in Boost	% of Final Regulation Voltage, $V_{SET} = \text{GND}$	●	95	98	%
$V_{PG_FALL_BST}$	PGOOD Pin Threshold Falling in Boost	% of Final Regulation Voltage, $V_{SET} = \text{GND}$	● 88	91		%
$V_{PG_RISE_TRK}$	PGOOD Pin Threshold Rising in Tracking	Offset from Programmed V_{OUT}		-1.5		V
$V_{PG_FALL_TRK}$	PGOOD Pin Threshold Falling in Tracking	Offset from Programmed V_{OUT}		-1.6		V
I_{PGOOD_HIGH}	PGOOD Output High Leakage Current	$V_{PGOOD} = 3\text{V}$	●		1	μA
V_{PGOOD_LOW}	PGOOD Output Low Voltage	$I_{PGOOD} = 0.2\text{mA}$	●	0.1	0.4	V

Note 1: Stresses beyond those listed under Absolute Maximum Ratings may cause permanent damage to the device. Exposure to any Absolute Maximum Rating condition for extended periods may affect device reliability and lifetime.

Note 2: The LTC3290 is tested under pulsed load conditions such that $T_J \approx T_A$. The LTC3290E is guaranteed to meet specifications from 0°C to 85°C junction temperature. Specifications over the -40°C to 125°C operating junction temperature range are assured by design, characterization and correlation with statistical process controls. The LTC3290I is guaranteed over the -40°C to 125°C operating junction temperature range, the LTC3290H is guaranteed over the -40°C to 150°C operating junction temperature range and the LTC3290MP is guaranteed over the -55°C to 150°C operating junction temperature range. Note that the maximum ambient temperature consistent with these specifications is determined by specific operating conditions in conjunction with board layout, the rated package thermal impedance and other environmental factors.

The junction temperature (T_J , in $^\circ\text{C}$) is calculated from the ambient temperature (T_A , in $^\circ\text{C}$) and power dissipation (P_D , in Watts) according to the formula:

$$T_J = T_A + (P_D \cdot \theta_{JA}),$$

where $\theta_{JA} = 45^\circ\text{C/W}$ is the package thermal impedance.

Note 3: This IC includes overtemperature protection that is intended to protect the device during momentary overload conditions. Junction temperatures will exceed 150°C when overtemperature protection is active. Continuous operation above the specified maximum operating junction temperature may result in device degradation or failure.

Note 4: This IC includes overvoltage protection that is intended to protect the device during momentary overload conditions. Pin voltages will exceed ABSMAX voltage ratings of the part while the protection is active. Continuous operation above the ABSMAX voltage ratings may result in device degradation or failure.

Note 5: Current limit is a protection feature. Refer to Available Output Current section in Applications Information for additional information. During a short-circuit event, the current limit is folded back further to reduce power dissipation.

TYPICAL PERFORMANCE CHARACTERISTICS

$T_A = 25^\circ\text{C}$, $C_{\text{FLY}} = 1\mu\text{F}$, $C_{\text{IN}} = C_{\text{AUX}} = C_{\text{OUT}} = 10\mu\text{F}$

unless otherwise noted.

Shutdown Current vs Temperature

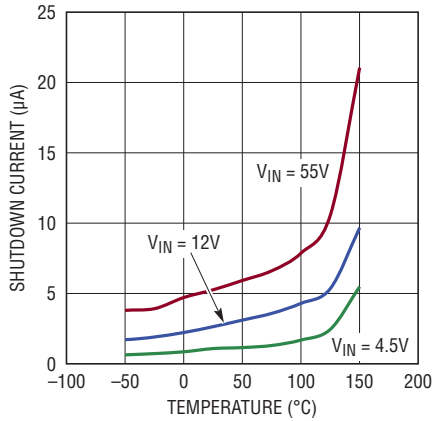

3290 G01

Quiescent Current vs Temperature (Boost Mode)

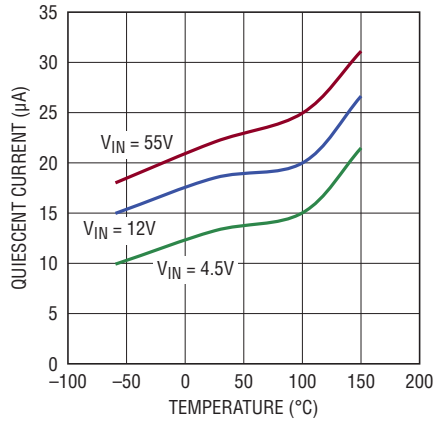

3290 G02

Quiescent Current vs Temperature (V_{IN} Tracking Mode)

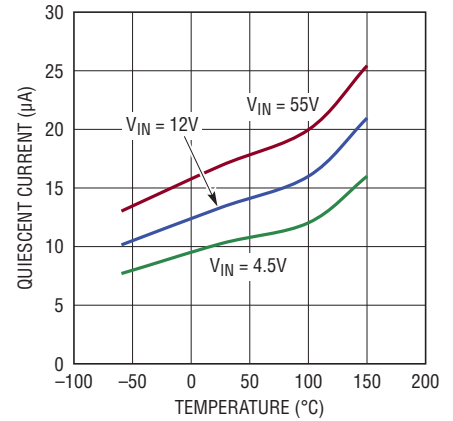

3290 G03

V_{OUT} Effective Open Loop Resistance vs Temperature

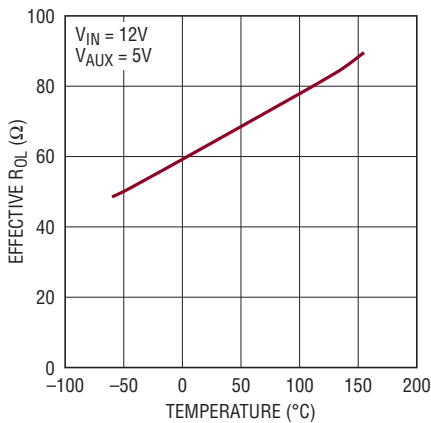

3290 G04

V_{OUT} Current Limit vs Supply Voltage

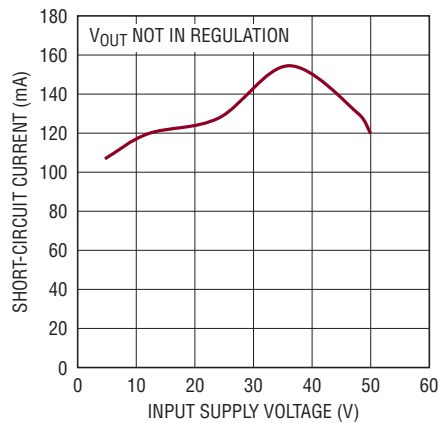

3290 G05

FB Pin Voltage vs Temperature

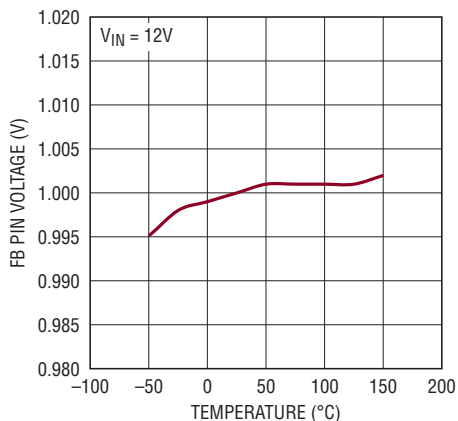

3290 G06

V_{BIAS} vs Supply Voltage

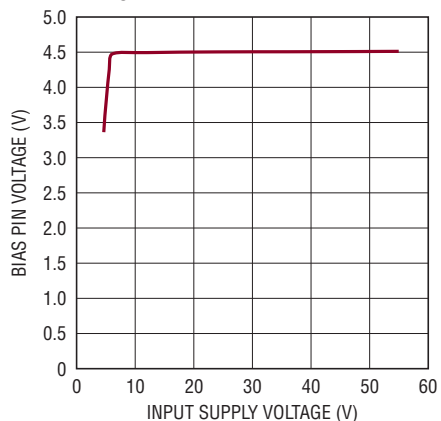

3290 G07

TYPICAL PERFORMANCE CHARACTERISTICS
 unless otherwise noted.

$T_A = 25^\circ\text{C}$, $C_{\text{FLY}} = 1\mu\text{F}$, $C_{\text{IN}} = C_{\text{AUX}} = C_{\text{OUT}} = 10\mu\text{F}$

V_{OUT} Output Ripple (Boost Mode)

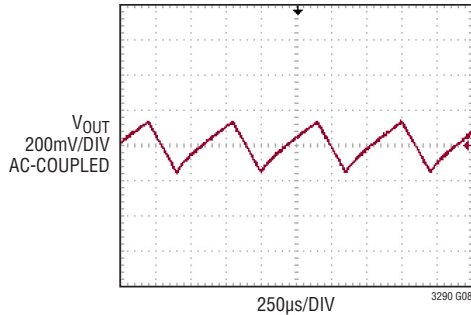

$V_{\text{IN}} = 12\text{V}$, $V_{\text{AUX}} = 5\text{V}$,
 $V_{\text{OUT}}^- = 15\text{V}$, $I_{\text{VOUT}} = 20\text{mA}$

V_{OUT} Transient (Boost Mode)

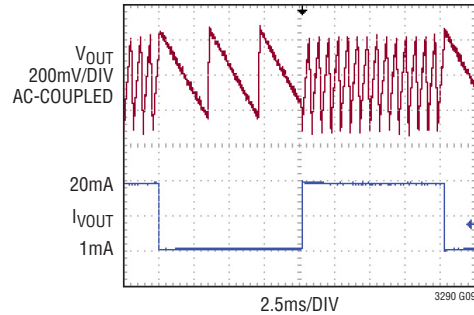

$V_{\text{IN}} = 12\text{V}$, $V_{\text{AUX}} = 5\text{V}$,
 $V_{\text{OUT}}^- = 15\text{V}$, $I_{\text{VOUT}} = 1\text{mA TO } 20\text{mA}$

V_{OUT} Output Ripple (Tracking Mode)

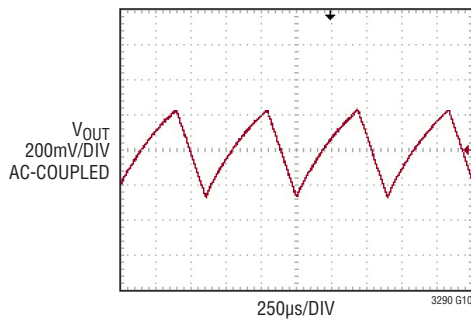

$V_{\text{IN}} = 12\text{V}$, $V_{\text{AUX}} = 12\text{V}$,
 $V_{\text{OUT}}^- = (V_{\text{IN}} + 10\text{V})$, $I_{\text{VOUT}} = 20\text{mA}$

V_{OUT} Transient (Tracking Mode)

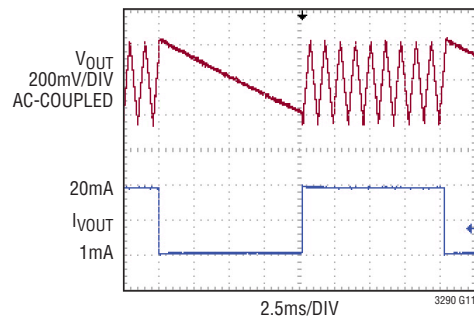

$V_{\text{IN}} = 12\text{V}$, $V_{\text{AUX}} = 12\text{V}$,
 $V_{\text{OUT}}^- = (V_{\text{IN}} + 10\text{V})$, $I_{\text{VOUT}} = 1\text{mA TO } 20\text{mA}$

PIN FUNCTIONS

V_{AUX} (Pin 1): Auxiliary Input Supply Voltage. V_{AUX} should be bypassed with a low impedance ceramic capacitor.

EN (Pin 2): Enable Logic Input. A logic high on the EN pin enables the part and regulates the output voltage to the desired value depending on the circuit configuration and the state of the V_{SET} pin. Do not float this pin.

C⁺ (Pin 3): Flying Capacitor Positive Connection.

C⁻ (Pin 4): Flying Capacitor Negative Connection.

V_{IN} (Pin 5): Input Supply Voltage. V_{IN} should be bypassed with a low impedance ceramic capacitor.

BIAS (Pin 6): Internal BIAS Voltage, 4.5V (typ). Connect this pin to a 4.7μF bypass capacitor to GND. A ceramic capacitor of at least 6.3V rating is recommended. The bias pin is for internal operation only and should not be loaded or driven externally.

PGOOD (Pin 7): Power Good Output. This open drain output is low when the part is enabled and the output is not in regulation. Once the part reaches regulation, this pin transitions to a Hi-Z state. An external resistor pull-up to a suitable voltage ≤ 3.6V is required to interface this pin with external circuitry such as a microprocessor.

FB (Pin 8): Feedback Input Voltage. When the V_{SET} pin is set to GND, the FB pin functions as a conventional feedback input pin. An external resistor divider from the V_{OUT} pin to GND sets the output voltage at the V_{OUT} pin. The FB

pin servos to 1V to achieve the desired output voltage at the V_{OUT} pin. In tracking mode, an external resistor from the FB pin to GND generates a reference current. This current is replicated at the V_{SET} pin. An external resistor from V_{OUT} to the V_{SET} pin sets the effective voltage at the V_{OUT} Pin. This configuration is used in the tracking mode, when V_{OUT} is desired to be set to a fixed offset voltage above the input voltage V_{IN}.

V_{SET} (Pin 9): Output Voltage Set Pin. An external resistor from this pin to the V_{OUT} pin sets the output voltage of the part in V_{IN} tracking mode. For conventional boost charge pump operation, this pin must be grounded. Do not float this pin.

V_{OUT} (Pin 10): Output Voltage. This pin should be bypassed with a low impedance ceramic capacitor to GND in normal boost charge pump mode or to the V_{IN} pin in V_{IN} tracking mode. When the V_{SET} pin is set to GND, the V_{OUT} pin voltage is set by an external divider between the V_{OUT}, FB and GND pins. In V_{IN} tracking mode, the V_{OUT} pin operates at a fixed offset voltage above the V_{IN} pin. The value of the offset voltage is set by a pair of external resistors, one from the V_{OUT} pin to the V_{SET} pin and another from the FB pin to GND.

GND (Exposed Pad Pin 11): Ground. The exposed package is ground and must be soldered to the PC board ground plane for proper functionality and for rated thermal performance.

BLOCK DIAGRAM

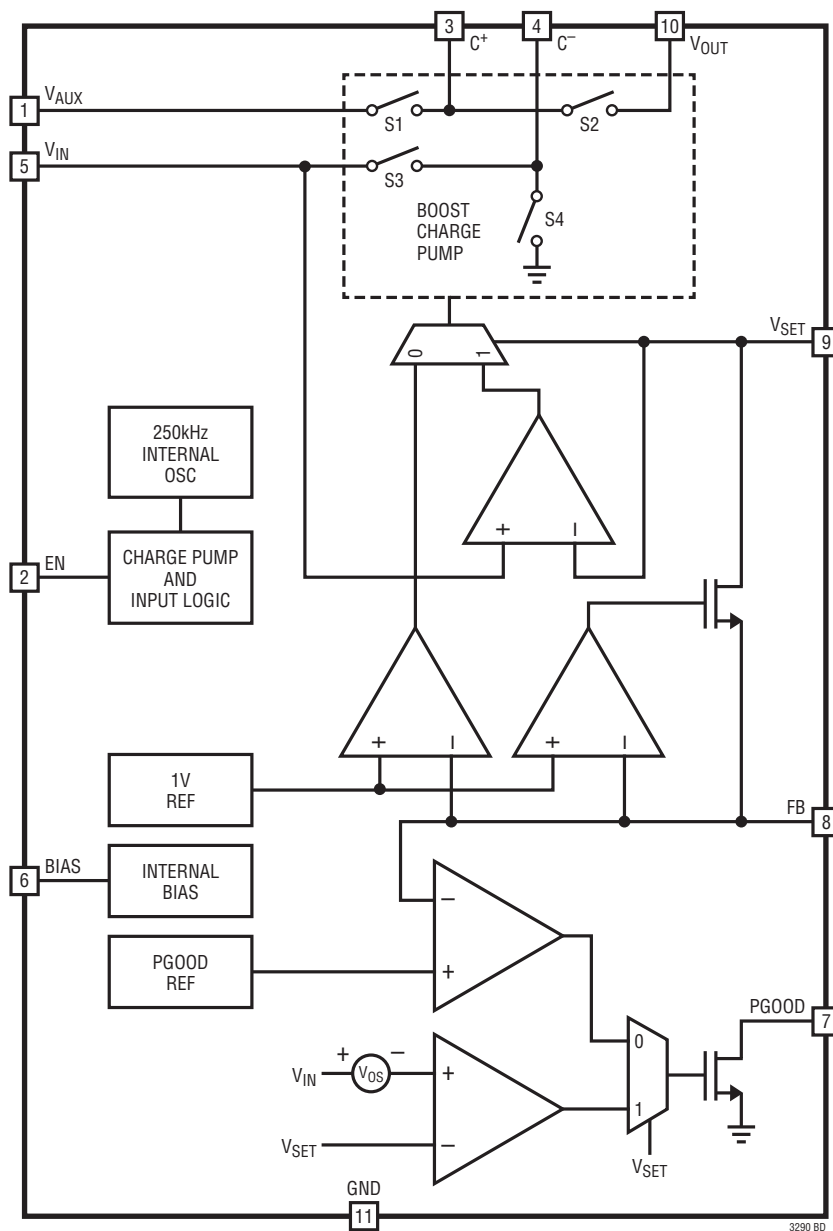

OPERATION (Refer to the Block Diagram)

The LTC3290 is a high voltage boost charge pump that uses an input power supply and an auxiliary supply to generate high efficiency boosted output voltages. It supports a wide input power supply range from 4.5V to 55V and a wide auxiliary power supply range from 4.5V to 55V to generate boosted output voltages up to 55V.

Shutdown Mode

In shutdown mode, all circuitry except the internal bias is turned off. The LTC3290 is in shutdown when a logic low is applied to the enable input (EN). The LTC3290 only draws 3µA (typ.) from the V_{IN} supply in shutdown. If the V_{AUX} pin is tied to V_{IN} it draws an additional 1µA (typ.) in shutdown.

Charge Pump Operation and V_{OUT} Regulation

The LTC3290 boost charge pump provides low power Burst Mode[®] operation. The boost charge pump and oscillator circuit are enabled using the EN pin. At the beginning of a clock cycle, switches S1 and S4 are closed. The external flying capacitor across the C⁺ and C⁻ pins is charged to the V_{AUX} supply. In the second phase of the clock cycle, switches S1 and S4 are opened, while switches S2 and S3 are closed. In this configuration the C⁻ side of the flying capacitor is connected to V_{IN} and charge is delivered through the C⁺ pin to V_{OUT}. An external resistor divider from V_{OUT} to the FB and GND pins sets the output voltage at the V_{OUT} pin.

The V_{OUT} output voltage is given by

$$V_{OUT} = 1V \cdot \left(\frac{R2}{R1} + 1 \right)$$

Once the V_{OUT} voltage reaches its programmed value, the part shuts down the internal oscillator to reduce switching losses and goes into a low current state. This state is referred to as the sleep state in which the part consumes only about 15µA from the V_{IN} pin. When the output voltage droops enough to overcome the burst comparator hysteresis, the part wakes up and commences boost charge pump cycles until the V_{OUT} output voltage exceeds the V_{OUT} programmed voltage. For low current operation, it is important to note that the external divider adds a current equal to $2 \cdot (1V/R1)$ to the total quiescent current. Recommended range of values for R1 is 100k to 500k.

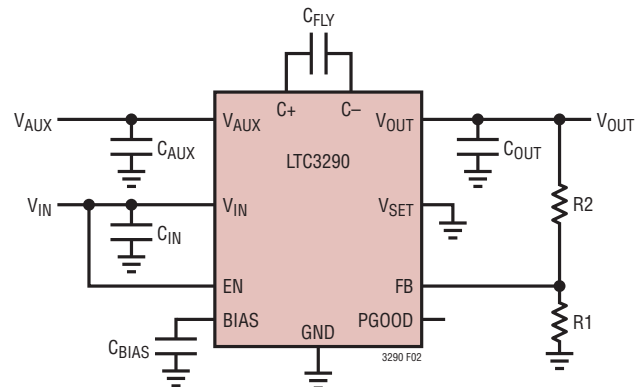

Figure 1. Boost Charge Pump with V_{OUT} Regulation

V_{IN} Tracking Mode

The LTC3290 can be configured to set the V_{OUT} voltage to track the V_{IN} voltage with a fixed offset as shown in Figure 2.

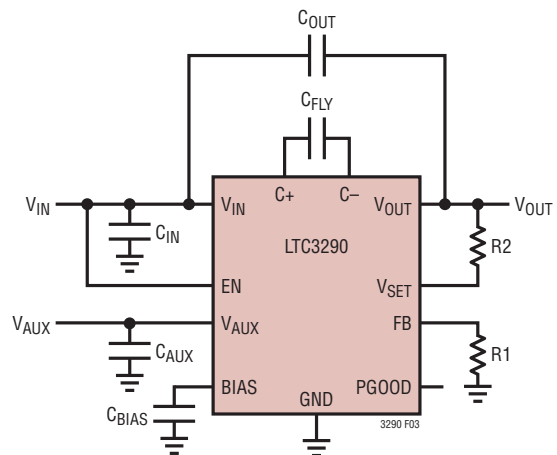

Figure 2. Boost Charge Pump with V_{IN} Tracking

The V_{OUT} output voltage in this configuration is given by

$$V_{OUT} = V_{IN} + 1V \cdot \left(\frac{R2}{R1} \right)$$

In this configuration, the FB pin serves to 1V. This voltage combined with the external resistor R1 creates a reference current which is mirrored into the other external resistor (R2) between the V_{OUT} and V_{SET} pins. The combination of these two resistors creates a fixed offset voltage above V_{IN} at the V_{OUT} pin. The magnitude of this offset is set only by external resistors R1 and R2. The auxiliary sup-

OPERATION (Refer to the Block Diagram)

ply (V_{AUX}) serves as an upper maximum for the offset voltage. R_2 and R_1 values must be chosen such that the offset voltage does not exceed V_{AUX} . For low quiescent current operation, it is important to note that the external divider adds a current equal to $2 \cdot (1V/R_1)$ to the total quiescent current. Recommended range of values for R_1 is 100k to 500k.

Soft-Start

The LTC3290 has built in soft-start circuitry to prevent excessive current flow during start-up. The soft-start is achieved by internal circuitry that slowly ramps the amount of current available at the output storage capacitors on the V_{OUT} pin. The soft-start circuitry is reset in the event of a commanded shutdown or thermal shutdown.

Short-Circuit/Thermal Protection

The LTC3290 has built-in short-circuit current limit as well as overtemperature protection. During an overcurrent condition, the part automatically limits output current from the V_{OUT} pin to 150mA (typ). In the event of a short-circuit on the V_{OUT} pin, the output current is dialed back to further reduce power dissipation. If the junction temperature exceeds approximately 175°C the thermal shutdown circuitry disables current delivery to the output. Once the junction temperature drops back to approximately 165°C, current delivery to the output resumes. When thermal protection is active the junction temperature is beyond the specified operating range. Thermal protection is intended for momentary overload conditions outside of normal operation. Continuous operation above the specified maximum operating junction temperature may impair device reliability.

APPLICATIONS INFORMATION

Available Output Current

For the LTC3290, the available output current can be calculated from the effective open-loop output resistance, R_{OL} , and the effective output voltage, $(V_{IN} + V_{AUX})_{(MIN)}$.

From Figure 3, the available current is given by:

$$I_{OUT} = \frac{(V_{IN} + V_{AUX}) - V_{OUT}}{R_{OL}}$$

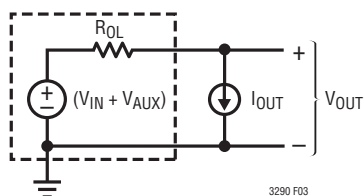

Figure 3. Equivalent Open-Loop Circuit

The value of the R_{OL} depends on many factors such as the internal oscillator frequency (f_{OSC}), the value of the flying capacitor (C_{FLY}), the nonoverlap time, the internal switch resistances (R_S) and the ESR of the external capacitors.

Typical R_{OL} values of the boost charge pump as a function of temperature are shown in Figure 4.

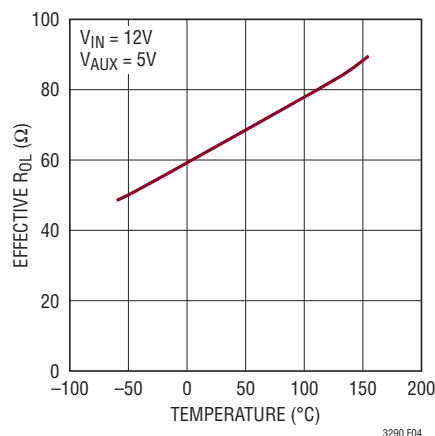

Figure 4. Typical R_{OL} vs Temperature

Input/Output Capacitor Selection

The style and value of the capacitors used with the LTC3290 determine several important parameters such as output ripple, charge pump strength and minimum turn-on time. To reduce noise and ripple, it is recommended that low ESR ceramic capacitors be used for the charge pump output. C_{OUT} should retain at least 5μF of capacitance over operating temperature and bias voltage. In Boost Mode, tantalum and aluminum capacitors can be used in parallel

APPLICATIONS INFORMATION

with a ceramic capacitor to increase the total capacitance but should not be used alone because of their high ESR. Increasing the size of C_{OUT} will reduce the output ripple at the expense of higher minimum turn-on time.

Just as the value of C_{OUT} controls the amount of output ripple, the values of C_{IN} and C_{AUX} control the amount of ripple present at the input pins (V_{IN} and V_{AUX}). The amount of bypass capacitance required at the input depends on the source impedance driving V_{IN} and V_{AUX} . For best results it is recommended that V_{IN} and V_{AUX} be bypassed with at least 5 μ F of low ESR capacitance. A high ESR capacitor such as tantalum or aluminum will have higher input noise than a low ESR ceramic capacitor. Therefore, a ceramic capacitor is recommended as the main bypass capacitance with a tantalum or aluminum capacitor used in parallel if desired.

Flying Capacitor Selection

The flying capacitor (C_{FLY}) controls the strength of the charge pumps. A 1 μ F or greater ceramic capacitor is suggested for the flying capacitor for applications requiring the full rated output current of the charge pump. Polarized capacitors such as aluminum or tantalum should not be used for C_{FLY} because the voltage on C_{FLY} can reverse during startup.

For very light load applications, the flying capacitor may be reduced to save space or cost. For example, a 0.2 μ F capacitor might be sufficient for load currents up to 10mA. A smaller flying capacitor leads to a larger effective open loop resistance (R_{OL}) and thus limits the maximum load current that can be delivered by the charge pump.

Ceramic Capacitors

Ceramic capacitors of different materials lose their capacitance with higher temperature and voltage at different rates. For example, a capacitor made of X5R or X7R material will retain most of its capacitance from -40°C to 85°C whereas a Z5U or Y5V style capacitor will lose considerable capacitance over that range. Z5U and Y5V capacitors may also have a poor voltage coefficient causing them to lose

60% or more of their capacitance when the rated voltage is applied. Therefore when comparing different capacitors, it is often more appropriate to compare the amount of achievable capacitance for a given case size rather than discussing the specified capacitance value. The capacitor manufacturer's data sheet should be consulted to ensure the desired capacitance at all temperatures and voltages. Below is a list of ceramic capacitor manufacturers and their websites.

AVX	www.avxcorp.com
Kemet	www.kemet.com
Murata	www.murata.com
Taiyo Yuden	www.t-yuden.com
Vishay	www.vishay.com
TDK	www.component.tdk.com

Layout Considerations

Due to high switching frequency and high transient currents produced by the LTC3290, careful board layout is necessary for optimum performance. A true ground plane and short connections to all the external capacitors will improve performance and ensure proper regulation under all conditions. Figure 5 shows an example layout for the LTC3290.

The flying capacitor nodes C^+ , and C^- switch large currents at a high frequency. These nodes should not be routed close to sensitive pins such as FB and V_{SET} pins.

Thermal Management

At high input voltages and maximum output current, there can be substantial power dissipation in the LTC3290. If the junction temperature increases above approximately 175°C , the thermal shutdown circuitry will automatically deactivate the output. To reduce the maximum junction temperature, a good thermal connection to the PC board ground plane is recommended. Connecting the exposed pad of the package to a ground plane under the device on two layers of the PC board can reduce the thermal resistance of the package and PC board considerably.

APPLICATIONS INFORMATION

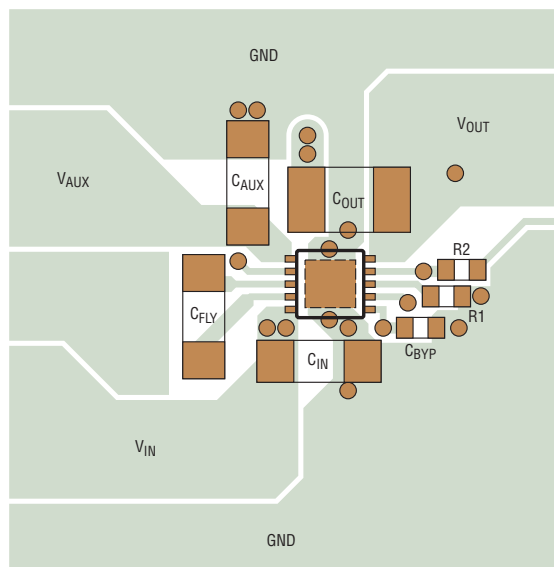

VIN TRACKING LAYOUT

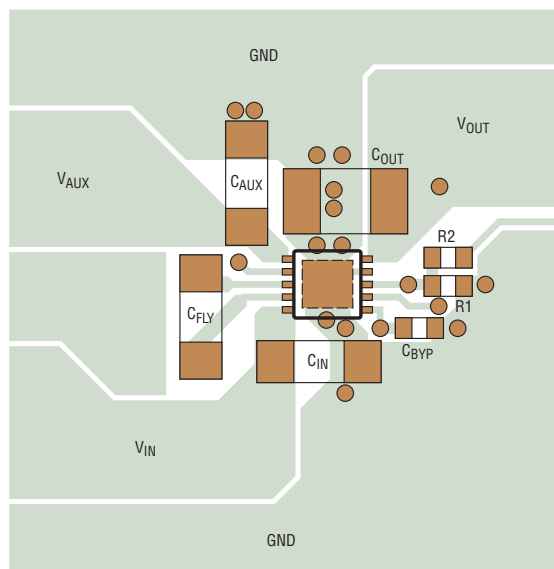

BOOST LAYOUT

Figure 5. Recommended Layout

Derating Power at High Temperatures

To prevent an overtemperature condition in high power applications, Figure 6 should be used to determine the maximum combination of ambient temperature and power dissipation.

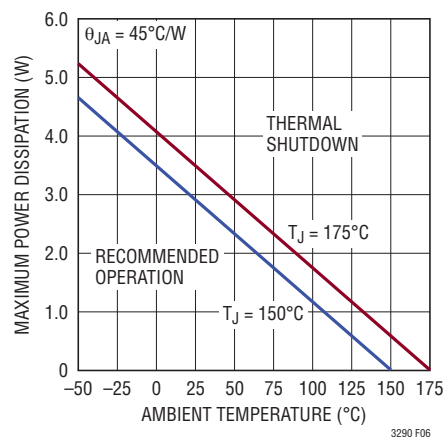

Figure 6. Maximum Power Dissipation vs Ambient Temperature

The power dissipated in the LTC3290 should always fall under the recommended operation line shown for a given ambient temperature.

Power dissipated in the LTC3290:

$$P_D = (V_{IN} + V_{AUX} - V_{OUT}) \cdot I_{OUT}$$

where I_{OUT} denotes the output load current.

The derating curve in Figure 6 assumes a maximum thermal resistance, θ_{JA} , of 45°C/W for the package. This can be achieved with a four layer PCB that includes 2oz Cu traces and six vias from the exposed pad of the LTC3290 to the ground plane.

It is recommended that the LTC3290 be operated in the region corresponding to $T_J \leq 150^\circ\text{C}$ for continuous operation as shown in Figure 6. Operation beyond 150°C should be avoided as it may degrade part performance and lifetime. At high temperatures, typically around 175°C, the part goes into thermal shutdown and all outputs are disabled. When the part cools back down to a low enough temperature, typically around 165°C, the outputs are re-enabled and the part resumes normal operation.

TYPICAL APPLICATIONS

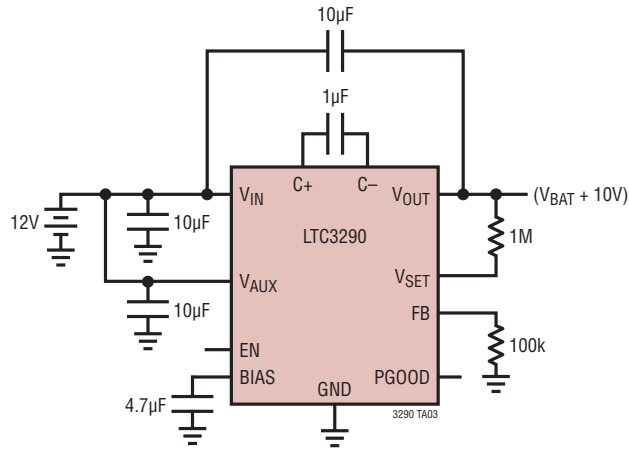

Figure 7. 10V Plus Battery Tracking Application

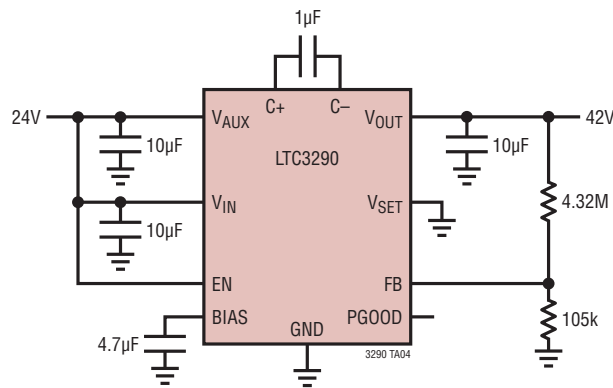

Figure 8. 24V to 42V Boost

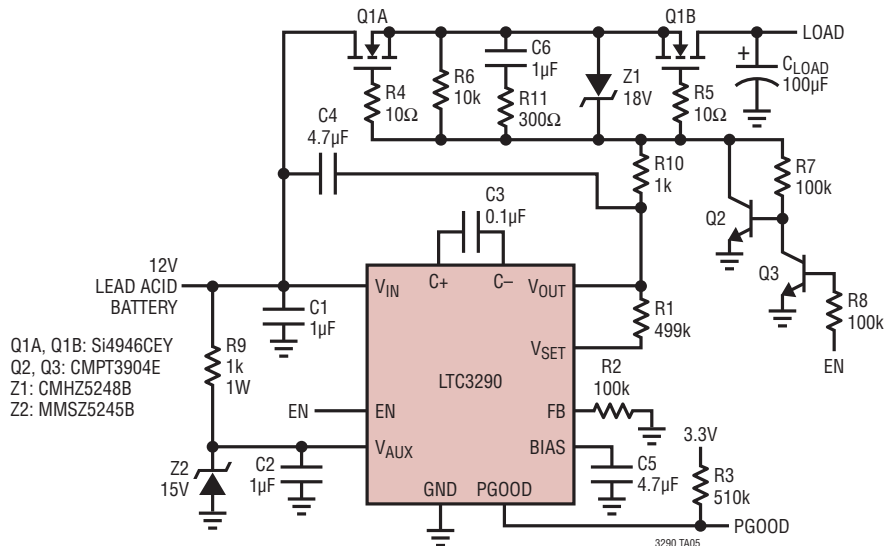
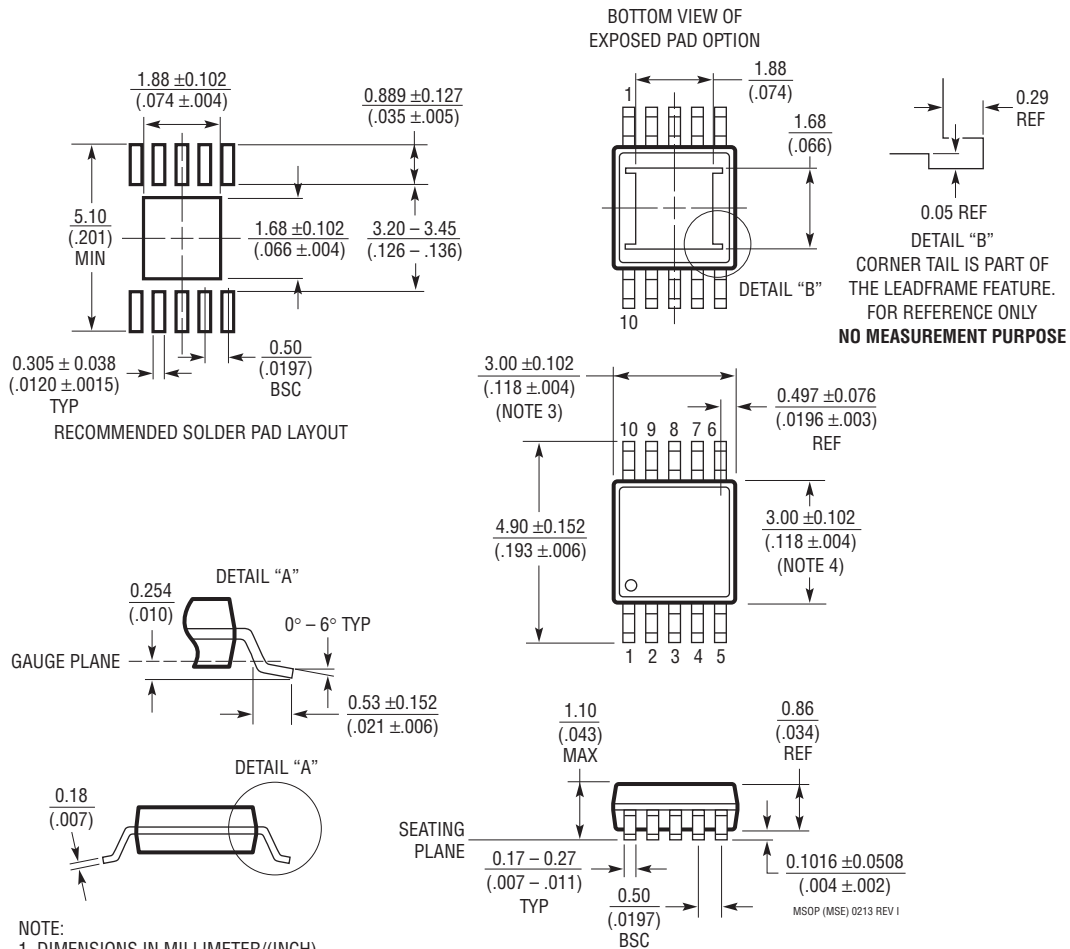

Figure 9. High Side FET Driver with Inrush Current Limiting and Load Disconnect

PACKAGE DESCRIPTION

MSE Package 10-Lead Plastic MSOP, Exposed Die Pad (Reference LTC DWG # 05-08-1664 Rev I)



NOTE:

1. DIMENSIONS IN MILLIMETER/(INCH)
2. DRAWING NOT TO SCALE
3. DIMENSION DOES NOT INCLUDE MOLD FLASH, PROTRUSIONS OR GATE BURRS.
MOLD FLASH, PROTRUSIONS OR GATE BURRS SHALL NOT EXCEED 0.152mm (.006") PER SIDE
4. DIMENSION DOES NOT INCLUDE INTERLEAD FLASH OR PROTRUSIONS.
INTERLEAD FLASH OR PROTRUSIONS SHALL NOT EXCEED 0.152mm (.006") PER SIDE
5. LEAD COPLANARITY (BOTTOM OF LEADS AFTER FORMING) SHALL BE 0.102mm (.004") MAX
6. EXPOSED PAD DIMENSION DOES INCLUDE MOLD FLASH. MOLD FLASH ON E-PAD SHALL NOT EXCEED 0.254mm (.010") PER SIDE.

REVISION HISTORY

REV	DATE	DESCRIPTION	PAGE NUMBER
A	6/24	Updated Features	1
		Updated Order Information	2

TYPICAL APPLICATION

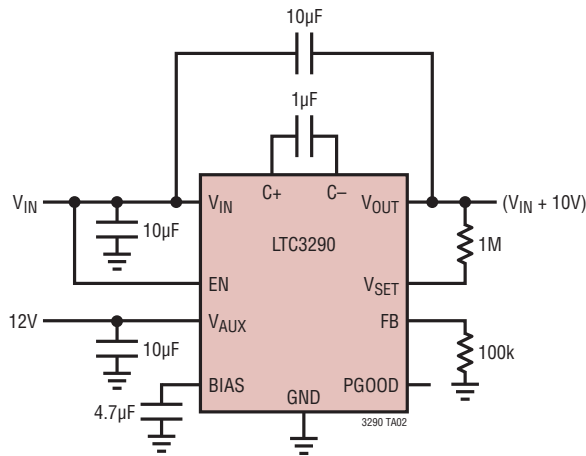
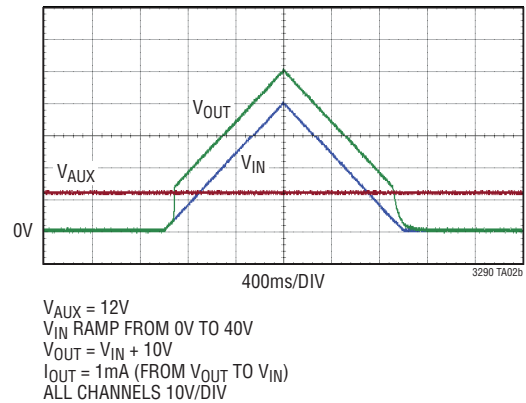
V_{OUT}, V_{IN} vs TimeFigure 10. (V_{IN} + 10V) Tracking Power Supply

RELATED PARTS

PART NUMBER	DESCRIPTION	COMMENTS
LTC1144	Switched-Capacitor Wide Input Range Voltage Converter with Shutdown	Wide Input Voltage Range: 2V to 18V, I _{SD} < 8µA, S08 Package
LTC1514/LTC1515	Step-Up/Step-Down Switched Capacitor DC/DC Converters	V _{IN} : 2V to 10V, V _{OUT} : 3.3V to 5V, I _Q = 60µA, S08 Package
LT1611	150mA Output, 1.4MHz Micropower Inverting Switching Regulator	V _{IN} : 0.9V to 10V, V _{OUT} : ±34V, ThinSOT™ Package
LT1614	250mA Output, 600kHz Micropower Inverting Switching Regulator	V _{IN} : 0.9V to 6V, V _{OUT} : ±30V, I _Q = 1mA, MS8, S08 Packages
LTC1911	250mA, 1.5MHz Inductorless Step-Down DC/DC Converter	V _{IN} : 2.7V to 5.5V, V _{OUT} : 1.5V/1.8V, I _Q = 180µA, MS8 Package
LTC3250/LTC3250-1.2/LTC3250-1.5	Inductorless Step-Down DC/DC Converter	V _{IN} : 3.1V to 5.5V, V _{OUT} : 1.2V, 1.5V, I _Q = 35µA, ThinSOT Package
LTC3251	500mA Spread Spectrum Inductorless Step-Down DC/DC Converter	V _{IN} : 2.7V to 5.5V, V _{OUT} : 0.9V to 1.6V, 1.2V, 1.5V, I _Q = 9µA, MS10E Package
LTC3252	Dual 250mA, Spread Spectrum Inductorless Step-Down DC/DC Converter	V _{IN} : 2.7V to 5.5V, V _{OUT} : 0.9V to 1.6V, I _Q = 50µA, DFN12 Package
LT1054/LT1054L	Switched Capacitor Voltage Converter with Regulator	V _{IN} : 3.5V to 15V/7V, I _{OUT} = 100mA/125mA, N8, S08, S016 Packages
LTC3260	Low Noise Dual Supply Inverting Charge Pump	V _{IN} : 4.5V to 32V, ILDO± = 50mA, DE14, MSE16 Packages
LTC3261	High Voltage, Low Quiescent Current Inverting Charge Pump	V _{IN} : 4.5V to 32V, I _{OUT} = 100mA, MSE12 Package
LTC3265	Low Noise Dual Supply with Boost and Inverting Charge Pumps	V _{IN} : 4.5V to 16V, ILDO± = 50mA, DFN18, TSSOP20 Packages
LTC3256	Wide V _{IN} Range, Dual Output 350mA Step-Down Charge Pump with Watchdog Timer	V _{IN} : 5.5V to 38V, V _{OUT} : 5V/3.3V, I _{OUT} = 100mA/250mA, MSE16 Package
LTC3245	Wide V _{IN} Range, Low Noise, 250mA Buck-Boost Charge Pump	V _{IN} : 2.7V to 38V, V _{OUT} : 2.5V to 5V/3.3V/5V, I _{OUT} = 250mA, DFN12 and MSE12 Packages
LTC3255	Wide V _{IN} Range, Fault Protected, 50mA Step-Down Charge Pump	V _{IN} : 4V to 48V, V _{OUT} : 2.4V to 12.5V, I _{OUT} = 50mA, DFN10 and MSE10 Packages