

316 hall

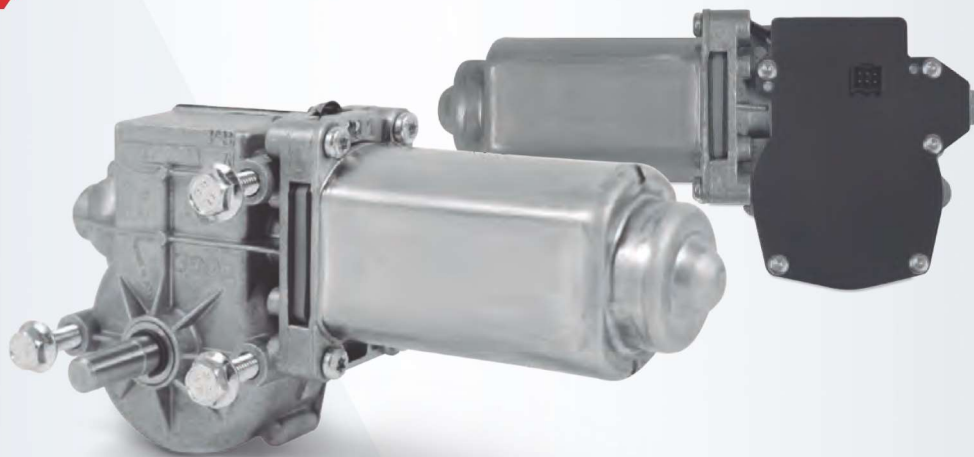

MOTOR FEATURES

REFERENCE NUMBER REFERENCIA REFERENZNUMMERN	NOMINAL VOLTAGE TENSION NOMINALE NENNSPANNUNG	NOMINAL TORQUE PAR NOMINAL COUPLE NOMINAL DREHMOMENT NOMINAL	NOMINAL SPEED VELOCIDAD NOMINAL VITESSE NOMINALE GESCHWINDIGKEIT NOMINAL	NOMINAL CURRENT CORRIENTE NOMINAL COURANT NOMINAL NOMINALSTROM	STARTING TORQUE PAR DE ARRANQUE COUPLE DE DEMARRAGE ANZUGSDREHMOMENT	STARTING CURRENT CORRIENTE DE ARRANQUE COURANT DE DEMARRAGE ANLAUFSTROM	SHAFT EJE ARBE WELLE	CONNECTIONS CONEXIONES CONNEXIONS ANSCHLUSSART	WIRING DIAGRAM ESQUEMA ELECTRICO SCHEMA ELECTRIQUE SCHALTBILD	TRANSMISSION RATIO RELACION DE REDUCCION RAPPORT DE REDUCTEUR UNTERSETZUNG	APPROXIMATE WEIGHT PESO APROXIMADO POIDS APPROXIMATIF GEWICHT (ca.)	WATER TIGHTNESS GRADO DE ESTANQUEIDAD ETANCHÉTE FEUCHTIGKEITSSCHUTZKASSE	WHEEL MATERIAL MATERIAL RUEDA MATERIAL ROUE MATERIAL DES SCHNECKENRADES	CURVE CURVA COURBE KURVE	PULSES NUM. Nº PULSOS NUM. PULSES IMPULSSANZahl
	Un (V)	Mn (N.m./lbf.in)	nn (r.p.m.)	In (A)	Ma (N.m./lbf.in)	Ia (A)				i	P (kg/lb)	IP			
31697472000	12	1.5 / 13.27	65	6.0	10 / 88.5	22	E30	C30/C44	EE4	62:1	0.90 / 1.98	IP10	PLA	57	310
31697473000	24	1.5 / 13.27	65	3.0	10 / 88.5	11	E30	C30/C44	EE4	62:1	0.90 / 1.98	IP10	PLA	57	310
31697512000	12	2 / 17.70	38	3.4	10 / 88.5	12	E30	C30/C44	EE4	62:1	0.90 / 1.98	IP10	PLA	56	310
31697513000	24	2 / 17.70	38	1.7	10 / 88.5	6	E30	C30/C44	EE4	62:1	0.90 / 1.98	IP10	PLA	56	310

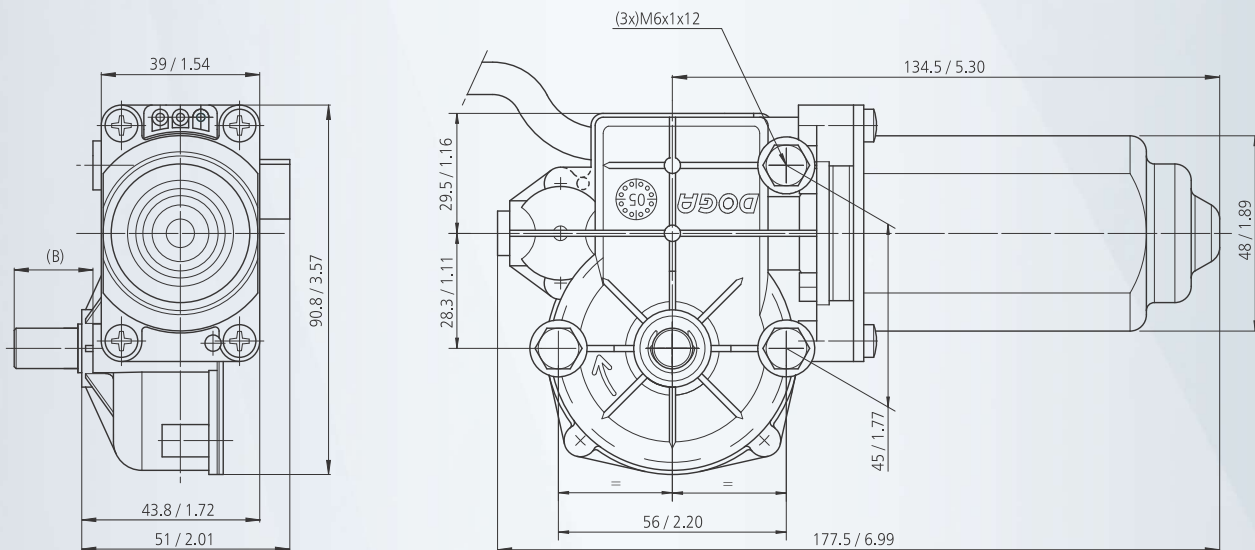

mm / inch

CONNECTIONS **CONEXIONES** CONNEXIONS ANSCHLUSSART

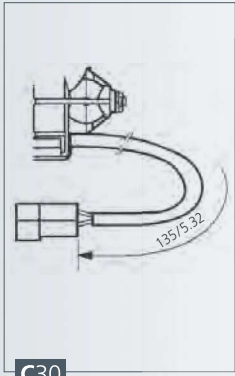

C30

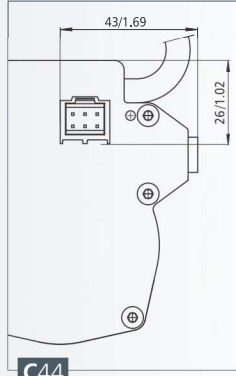

C44

PIN FUNCTION - FUNCIÓN

1	-
2	OUT A
3	OUT B
4	-
5	GND
6	VCC

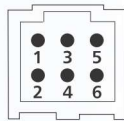

Connector MOLEX 90130-1206 and terminals 90119-2121
 Counter connector (not included) MOLEX 90142-0006

SHAFT **EJE** ARBRE **WELLE**

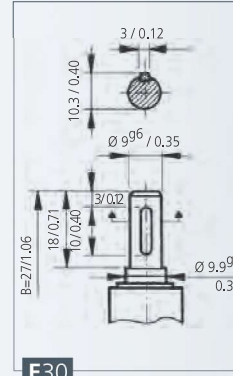

E30

WIRING DIAGRAM **ESQUEMA ELÉCTRICO** SCHEMA ÉLECTRIQUE **SCHALTBILD**

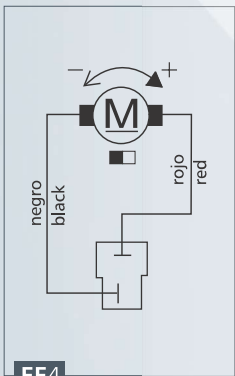

EE4

SENSOR HALL **ESQUEMA SENSOR HALL**
 SCHEMA SENSOR HALL **SCHALTBILD HALLSENSOR**

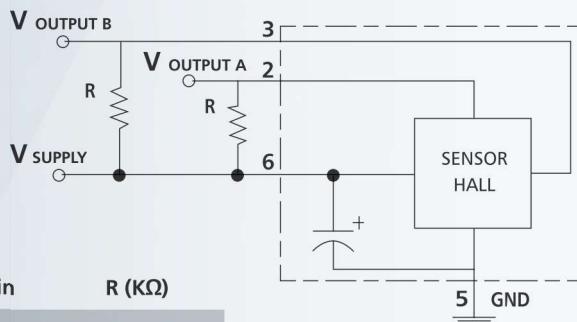

Vout = Vin R (KΩ)

5V	0.5
12V	1.2
24V	2.4

CURVES **CURVAS** COURBES **KURVEN**

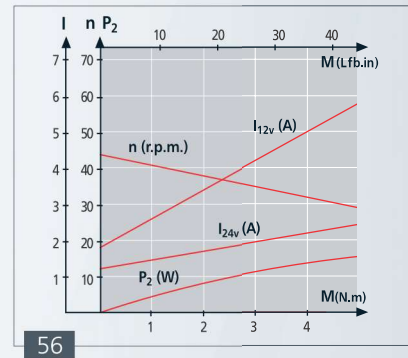

56

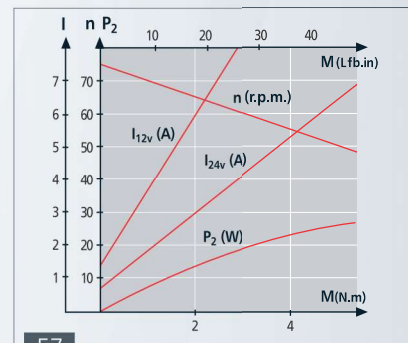

57

OUTPUT SIGNAL **SEÑAL DE SALIDA**
 SIGNALISATION DE SORTIE **AUSGANGSSIGNAL**

