

Motor-pump group

RE 51172/ 11.12

1/14

Type ABAPG

with pump type: A4VSO
Series 10, 30: Size 0040 to 0500
Electric motor frame size 180M to 400M

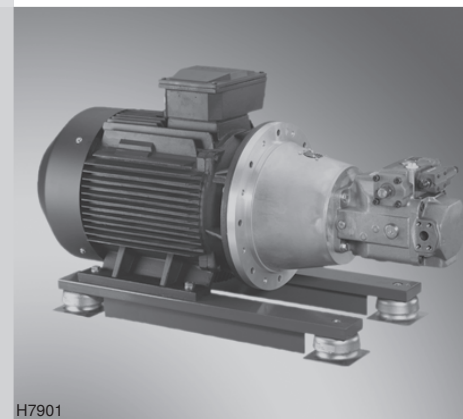

H7901

Table of contents

Contents	Page
Features	1
Ordering code	2
Set-up of the motor-pump group	2
Technical data	3, 4
Circuit diagrams	5
Standard type selection table	6
Device dimensions	7 ... 10
Pressure line connections	11
Optional accessories	11, 12
Installation information	13
Commissioning, maintenance and operating instructions	13

Features

- In the motor-pump groups, electric energy is converted into hydraulic energy.
- They have been designed for hydrostatic drives in open circuits.
- Electric motor, design IM B3/B5 (ABAPG)
 - Pump fastened at the electric motor with rigid pump carrier and coupling
 - Versatile possible applications on tank, base frame or separate installation
 - Clear, maintenance-friendly set-up
 - With axial piston pump A4VSO (variable displacement pump)
 - Adjustment of DR (pressure controller) and DRG (pressure controller, hydraulically remote controlled for size 355)

Ordering code

ABAPG – A4VSO P P / CB 4 5 2 3 / S E HOY

Assembly

with motor design B35 = ABAPG

Pump type

Axial piston pump A4VSO
According to data sheet 92050 = A4VSO

Displacement

40 ... 500 cm³ per rotation = 40 ... 500

Control and adjustment device

e.g.
Pressure controller (size 0040–250, 500) = DR
Hydraulically remote controlled pressure controller (size 0355) = DRG

Seal material (according to DIN ISO 1629)

NBR = P

Shaft end version

Cylindrical with fitting key DIN 6885 = P

Mounting flange

ISO 4-hole = B
ISO 8-hole = H

Motor supplier

HOY = Hoyer Motors (preferred)
SIE = Siemens
VEM = VEM

Damping bearing design

E = Elastic damping bearing

Pump carrier design

S = Rigid pump carrier AB 03337

Motor protection

3 = PTC resistor with 3 temperature sensors

Efficiency class

2 = IE 2

Rated frequency

5 = 50 Hz

Number of pole pairs

4 = 4-pole

Rated voltage

CB = 400/690 at 50 Hz

Motor power

15 ... 400 = 15 ... 400 kW

Order example:

ABAPG-A4VSO180DRPPB/110CB4523/SE HOY

Set-up of the motor-pump group

ABAPG design

- Pump
- Electric motor
- Pump carrier
- Coupling
- Strips
- Damping bearing

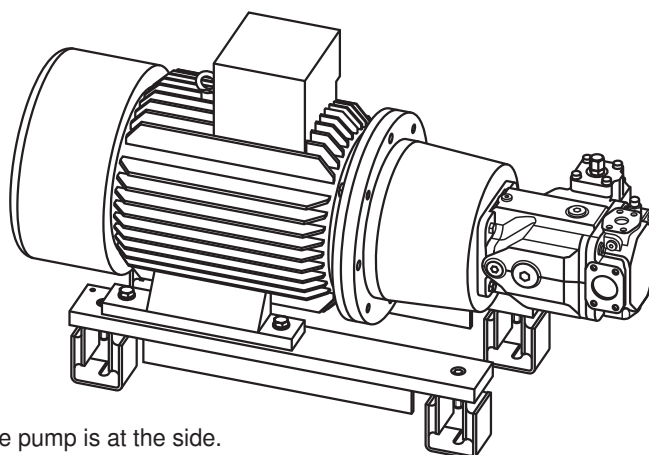

By default, the suction port of the pump is at the side.
Pump can be turned in 90° steps.

STEP files of the relevant assemblies on request

Technical data (For applications outside these parameters, please consult us!)

Line connections	See table Line connections on page 11		
Hydraulic fluid	Mineral oil HLP according to DIN 51524; part 2 e.g. with operating temperature 50 °C ISO VG46 DIN ISO 3448 (other fluids on request!) <ul style="list-style-type: none"> • Please observe our provisions according to data sheet 90220, 90221, 90223. • Different oil types must not be mixed as this might result in degradation and deterioration of the lubricity. • According to the operating conditions, the fluid must be renewed at certain intervals. 		
Pump type	A4VSO according to data sheet 92050		
– Direction of rotation	R = clockwise		
Operating pressure, absolute			
– Inlet	$p_{\min-\max}$	bar	0.8 to 30
– Output	p_{nom}	bar	350
– Peak pressure	p_{\max}	bar	400
– Leakage port	p_{\max}	bar	4
Hydraulic fluid temperature range, observe viscosity range	ϑ		–25 to +90
– T_{optimal} with HLP 46 (DIN 51524)	ϑ	°C	+40 to +50
– T_{\max} in continuous operation	ϑ	°C	< +65
For start-up at low temperatures a heating can be provided. For cooling, you can either provide an oil/water or an oil/air cooler. See data sheet 50126 (ABUKG) and 50112 (KOL/KOLP).			
Cleanliness classes according to ISO code	Maximum admissible degree of contamination of the hydraulic fluid according to ISO 4406 (c) depending on the pump type used ¹⁾ . At least cleanliness class 20/18/15 must be achieved.		
Viscosity range	ν	mm ² /s	16 to 36 optimally 10 to 1000 for short periods (see data sheet 92050)
Electric motor	– Motor type	Three-phase asynchronous motor	
	– Efficiency class	IE2	
	– Number of pole pairs	4	
	– Voltage according to IEC 38 U	V	400 / 690 at 50 Hz (CB)
	– Speed	$n \text{ min}^{-1}$	1450 at 50 Hz
	– Protection class	IP	55
	– Installation position	Horizontal	
Surface treatment	By default, all steel components and components are at least provided with temporary corrosion protection (e.g. for transport).		

¹⁾ The cleanliness classes specified for the components must be adhered to in hydraulic systems. Effective filtration prevents faults and at the same time increases the life cycle of the components.

For selecting the filters, see data sheet 51501.

 **Notice:** For assembly, commissioning and maintenance of hydraulic systems please observe the data sheet 07900. The motor-pump group is constructed and manufactured in accordance with the harmonized EN standards/specifications.

Technical data: Hydraulic fluid

(For applications outside these parameters, please consult us!)

Operating viscosity range

The unit can be operated within the operating viscosity range of 16...100 mm²/s without limitation of the technical data.

We recommend selecting the operating viscosity (at operating temperature) in the optimal range for efficiency and service life of

$$v_{\text{opt}} = \text{opt. operating viscosity } 16\text{...}36 \text{ mm}^2/\text{s},$$

relating to the tank temperature (open circuit).

Limit viscosity range

The following values apply to limit operating conditions:

$$v_{\text{min}} = 10 \text{ mm}^2/\text{s}$$

for short periods ($t < 3 \text{ min}$) at max. admissible leakage temperature

$$t_{\text{max}} = +90^\circ \text{C}$$

$$v_{\text{max}} = 1000 \text{ mm}^2/\text{s}$$

for start-up only (cold start, within 15 min. an operating viscosity of less than 100 mm²/s should be reached)

$$t_{\text{min}} \text{ to } -25^\circ \text{C}$$

For detailed information on the use at low temperatures see data sheet 90300-03-B.

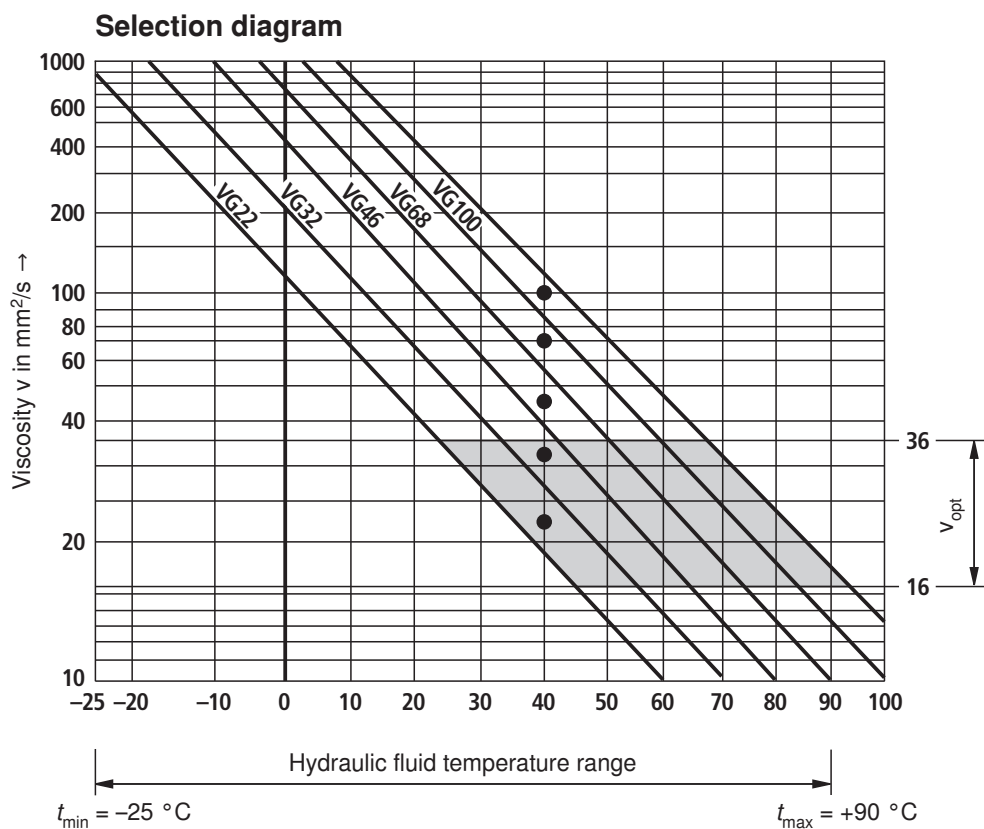

Notes on hydraulic fluid selection

The hydraulic fluid should be selected so as to ensure that, within the operating temperature range, the operating viscosity is within the optimal range (v_{opt}), see selection diagram, grayed-out field.

We recommend choosing the next higher viscosity class.

Temperature range (compare selection diagram)

$$t_{\text{min}} = -25^\circ \text{C}$$

$$t_{\text{max}} = +90^\circ \text{C}$$

Example:

At an ambient temperature of X °C the tank has an operating temperature of 60 °C. Within the optimal operating viscosity range (v_{opt} ; grayed-out field) this corresponds to the viscosity classes VG 46 or VG 68; to select: VG 68.

Note:

The leakage temperature, influenced by pressure and speed, is always higher than the tank temperature. However, the temperature must never exceed 90 °C at any point of the system.

Circuit diagrams

Axial piston pump DR controller

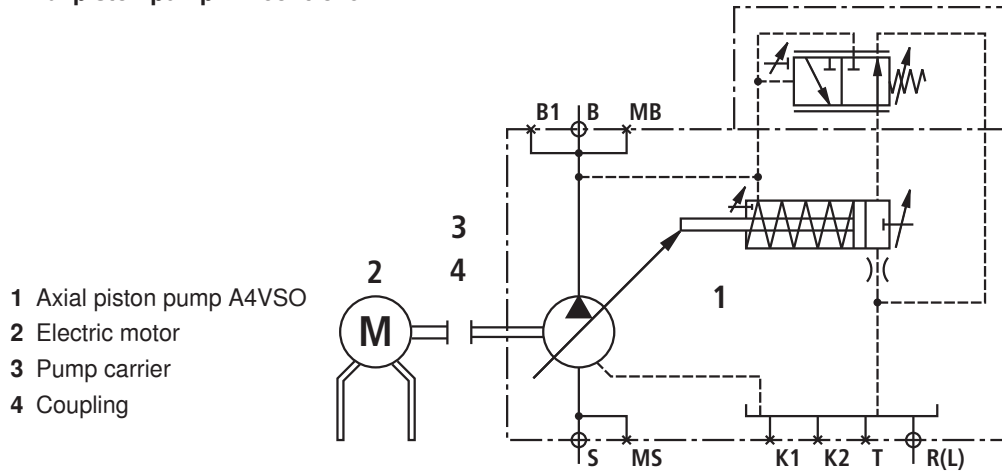

Axial piston pump DRG controller

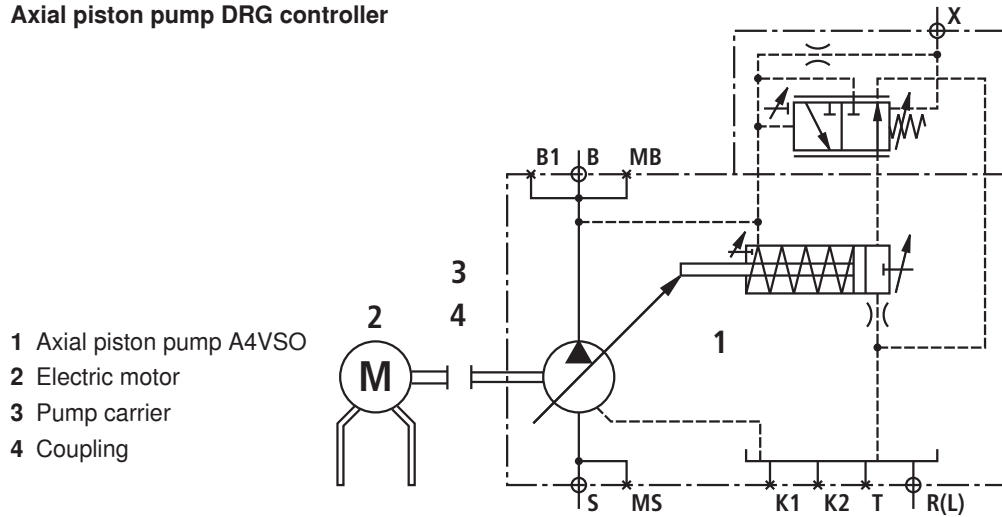

Standard type selection table ABAPG – A4VSO

Pump A4VSO...	Frequency		$P_{max.}$ in bar	Power in kW	Electric motor frame size	ABAPG Material no. (motor B35)			ABAPG Material no. (motor B35) prepared for PSBD ¹⁾		
	$q_{v, max}$ in l/min	50 Hz 1450 min ⁻¹				HOYER Motors	VEM	SIEMENS	HOYER Motors	VEM	SIEMENS
40	55	156	18.5	180M	R901317969	R901318008	R901318043	R901318101	R901318212	R901318256	
		195	22.0	180L	R901317970	R901318009	R901318044	R901318102	R901318213	R901318257	
		278	30.0	200L	R901317971	R901318010	R901318045	R901318103	R901318214	R901318258	
		348	37.0	225S	R901317972	R901318011	R901318046	R901318104	R901318215	R901318259	
		350	45.0	225M	R901317973	R901318012	R901318048	R901318105	R901318216	R901318260	
71	98	150	30.0	200L	R901317974	R901318013	R901318049	R901318106	R901318217	R901318261	
		185	37.0	225S	R901317975	R901318014	R901318050	R901318107	R901318218	R901318262	
		238	45.0	225M	R901317976	R901318015	R901318051	R901318108	R901318219	R901318263	
		295	55.0	250M	R901317977	R901318016	R901318053	R901318109	R901318220	R901318264	
		350	75.0	280S	R901317978	R901318017	R901318054	R901318110	R901318221	R901318265	
125	172	162	55.0	250M	R901317979	R901318018	R901318055				
		227	75.0	280S	R901317980	R901318019	R901318056				
		276	90.0	280M	R901317981	R901318020	R901318057		-		
		342	110.0	315S	R901317982	R901318021	R901318058				
		350	132.0	315M	R901317983	R901318022	R901318059				
180	248	160	75.0	280S	R901317984	R901318023	R901318060				
		193	90.0	280M	R901317985	R901318024	R901318061				
		237	110.0	315S	R901317986	R901318025	R901318062				
		282	132.0	315M	R901317987	R901318026	R901318063		-		
		344	160.0	315L	R901317988	R901318027	R901318064				
		350	200.0	315L/315M	R901317989	R901318028	On request				
250	344	167	110.0	315S	R901317990	R901318029	R901318066				
		203	132.0	315M	R901317991	R901318030	R901318067				
		249	160.0	315L	R901317992	R901318031	R901318068		-		
		311	200.0	315L/315M	R901317993	R901318032	On request				
		350	250.0	355M/315L	R901317994	R901318033	R901318070				
355	489	169	160.0	315L	R901317995	R901318034	R901318072				
		212	200.0	315L/315M	R901317996	R901318035	On request				
		267	250.0	355M/315L	R901317997	R901318036	R901318074		-		
		334	315.0	355L/315L	R901317998	R901318037	R901318076				
500	689	150	200.0	315L/315M	R901317999	R901318038	On request				
		191	250.0	355M/315L	R901318000	R901318039	R901318078				
		247	315.0	355L/315L	R901318001	R901318040	R901318079		-		
		274	355.0	355L	R901318003	On request	On request				
		314	400.0	400M	R901318005	On request	On request				

All types are part of the standard delivery range (A3)
Device dimensions see page 7-10

¹⁾ Other degree of hardness of the damping bearings. Pump manifold block PSBD02 (data sheet 62300) must be ordered separately.

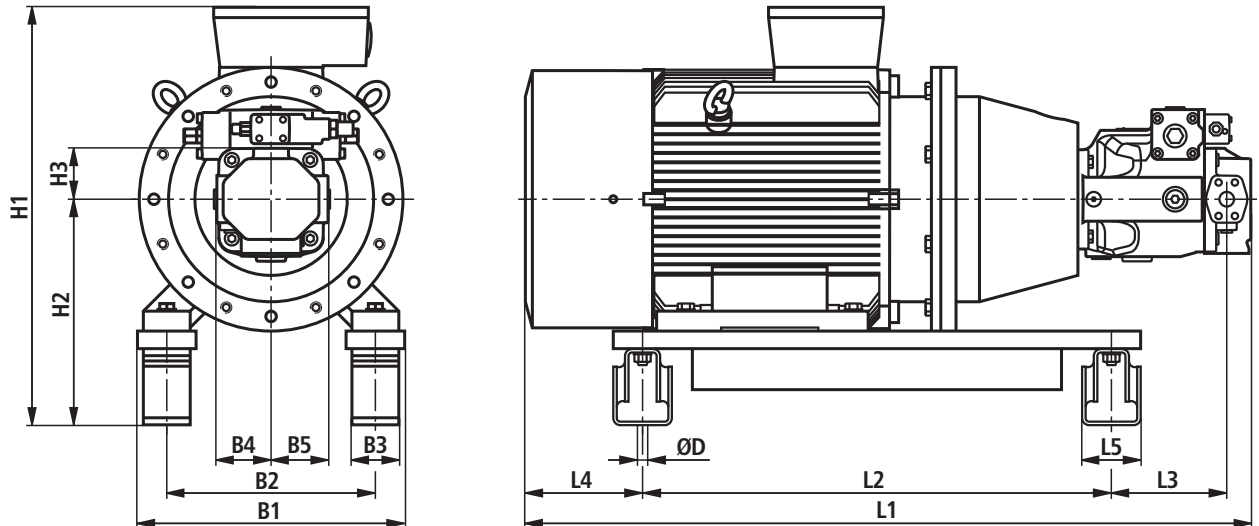
Device dimensions: Type ABAPG-A4VSO 40DR – 125DR (dimensions in mm)

ABAPG-A4VSO with motor supplier HOYER-MOTORS

Pump A4VSO...	Electric motor kW / frame size	Dimensions													Weight [kg]
		B1	B2	B3	B4/B5	ØD	H1	H2	H3	L1	L2	L3	L4	L5	
40DR	18 / 180M	369	279	65	80	17.5	588	313	75	1170	620	247	264	87	254
	22 / 180L	369	279	65	80	17.5	588	313	75	1210	620	247	304	87	281
	30 / 200L	418	318	80	80	17.5	665	360	75	1240	700	214	287	100	361
	37 / 225S	456	356	80	80	17.5	720	385	75	1315	800	170	306	100	456
	45 / 225M	456	356	80	80	17.5	720	385	75	1345	800	170	336	100	475
71DR	30 / 200L	418	318	80	92.5	17.5	665	360	85	1293	700	265	287	100	377
	37 / 225S	456	356	80	92.5	17.5	720	385	85	1344	800	197	306	100	472
	45 / 225M	456	356	80	92.5	17.5	720	385	85	1374	800	197	336	100	491
	55 / 250M	526	406	80	92.5	17.5	785	420	85	1458	850	229	338	100	586
125DR	55 / 250M	526	406	80	113	17.5	785	420	100	1535	850	302	338	100	629

ABAPG-A4VSO with motor supplier VEM

Pump A4VSO...	Electric motor kW / frame size	Dimensions													Weight [kg]
		B1	B2	B3	B4/B5	ØD	H1	H2	H3	L1	L2	L3	L4	L5	
40DR	18 / 180M	369	279	65	80	17.5	574	313	75	1150	620	247	244	87	290
	22 / 180L	369	279	65	80	17.5	574	313	75	1150	620	247	244	87	360
	30 / 200L	418	318	80	80	17.5	660	360	75	1197	700	214	244	100	380
	37 / 225S	456	356	80	80	17.5	685	385	75	1257	800	170	248	100	437
	45 / 225M	456	356	80	80	17.5	709	385	75	1362	800	170	353	100	502
71DR	30 / 200L	418	318	80	92.5	17.5	660	360	85	1250	700	265	244	100	396
	37 / 225S	456	356	80	92.5	17.5	685	385	85	1286	800	197	248	100	453
	45 / 225M	456	356	80	92.5	17.5	709	385	85	1391	800	197	353	100	518
	55 / 250M	526	406	80	92.5	17.5	806	420	85	1467	850	229	347	100	699
125DR	55 / 250M	526	406	80	113	17.5	806	420	100	1544	850	302	347	100	742

ABAPG-A4VSO with motor supplier SIEMENS

Pump A4VSO...	Electric motor kW / frame size	Dimensions													Weight [kg]
		B1	B2	B3	B4/B5	ØD	H1	H2	H3	L1	L2	L3	L4	L5	
40DR	18 / 180M	369	279	65	80	17.5	575	313	75	1139	620	247	233	87	235
	22 / 180L	369	279	65	80	17.5	757	313	75	1190	620	247	284	87	265
	30 / 200L	418	318	80	80	17.5	660	360	75	1190	700	214	237	100	325
	37 / 225S	456	356	80	80	17.5	713	385	75	1289	800	170	280	100	397
	45 / 225M	456	356	80	80	17.5	713	385	75	1349	800	170	340	100	427
71DR	30 / 200L	418	318	80	92.5	17.5	660	360	85	1243	700	265	237	100	341
	37 / 225S	456	356	80	92.5	17.5	713	385	85	1318	800	197	280	100	413
	45 / 225M	456	356	80	92.5	17.5	713	385	85	1378	800	197	340	100	443
	55 / 250M	526	406	80	92.5	17.5	812	420	85	1494	850	229	374	100	595
125DR	55 / 250M	526	406	80	113	17.5	812	420	100	1571	850	302	374	100	637

Device dimensions: Type ABAPG-A4VSO 71DR – 500DR HOYER-MOTORS

(dimensions in mm)

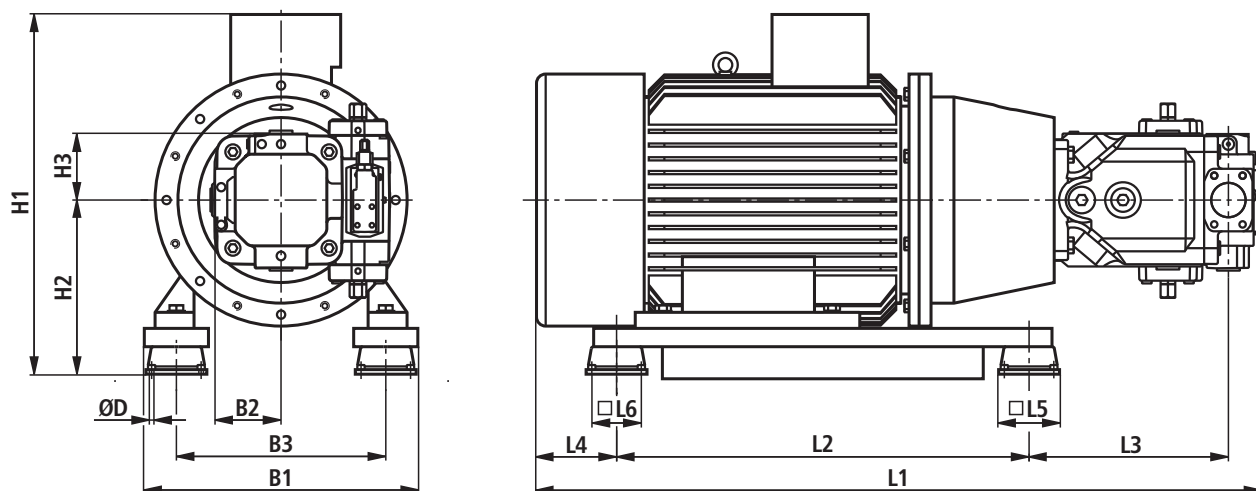
**ABAPG-A4VSO with motor supplier HOYER-MOTORS**

Pump A4VSO...	Electric motor kW / frame size	Dimensions													Weight [kg]
		B1	B2	B3	ØD	H1	H2	H3	L1	L2	L3	L4	L5	L6	
71DR	75 / 280S	597	92.5	457	11.9	780	380	85	1535	900	279	315	133	108	867
125DR	75 / 280S	597	113	457	11.9	780	380	100	1595	900	335	315	133	108	910
	90 / 280M	597	113	457	11.9	780	380	100	1645	900	335	365	133	108	910
	110 / 315S	648	113	508	13.5	972	442	100	1910	1100	251	514	175	143	1265
	132 / 315M	648	113	508	13.5	972	442	100	2020	1100	251	624	175	143	1475
180DR	75 / 280S	597	116	457	11.9	780	380	100	1615	900	343	315	133	108	922
	90 / 280M	597	116	457	11.9	780	380	100	1665	900	343	365	133	108	922
	110 / 315S	648	116	508	13.5	972	442	100	1930	1100	259	514	175	143	1310
	132 / 315M	648	116	508	13.5	972	442	100	2040	1100	259	624	175	143	1490
	160 / 315L	648	116	508	13.5	972	442	100	2060	1100	329	574	175	143	1605
250DR	200 / 315L	648	116	508	13.5	972	442	100	2060	1100	329	574	175	143	1660
	110 / 315S	648	144	508	13.5	972	442	133	2010	1100	341	514	175	143	1395
	132 / 315M	648	144	508	13.5	972	442	133	2120	1100	341	624	175	143	1575
	160 / 315L	648	144	508	13.5	972	442	133	2120	1100	391	574	175	143	1645
	200 / 315L	648	144	508	13.5	972	442	133	2120	1100	391	574	175	143	1700
355DRG	250 / 355M	770	144	610	13.5	1147	492	133	2315	1400	299	561	175	143	2380
	160 / 315L	648	144	508	13.5	972	442	133	2149	1100	404	574	175	143	1660
	200 / 315L	648	144	508	13.5	972	442	133	2149	1100	404	574	175	143	1715
	250 / 355M	770	144	610	13.5	1147	492	133	2389	1400	357	561	175	143	2410
500DR	315 / 355L	770	144	610	13.5	1147	492	133	2389	1400	357	561	175	143	2580
	200 / 315L	648	180	508	13.5	972	442	190	2270	1100	517	574	175	143	1880
	250 / 355M	770	180	610	13.5	1147	492	190	2460	1400	420	561	175	143	2510
	315 / 355L	770	180	610	13.5	1147	492	190	2508	1400	468	561	175	143	2670
	355 / 355L	770	180	610	13.5	1147	492	190	2508	1400	468	561	175	143	3250
400 / 400M	886	180	686	13.5	1267	567	190	2880	1700	391	710	175	143	4840	

Device dimensions: Type ABAPG-A4VSO 71DR – 500DR VEM

(dimensions in mm)

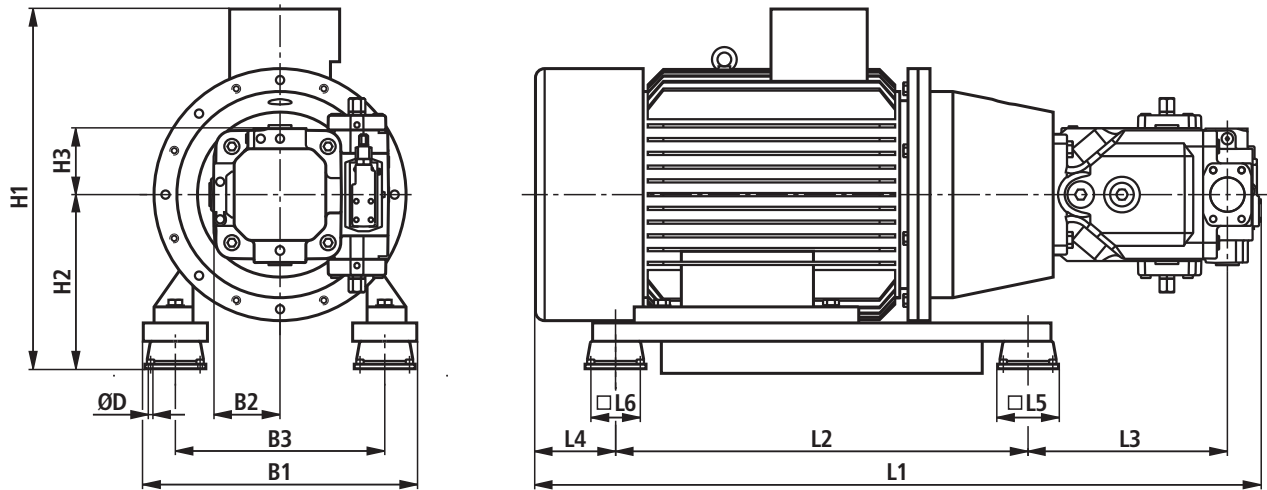

ABAPG-A4VSO with motor supplier VEM

Pump A4VSO...	Electric motor kW / frame size	Dimensions												Weight [kg]	
		B1	B2	B3	ØD	H1 ¹⁾	H2 ¹⁾	H3	L1	L2	L3	L4	L5		L6
71DR	75 / 280S	597	92.5	457	11.9	766	380	85	1484	900	279	264	133	108	749
125DR	75 / 280S	597	113	457	11.9	766	380	100	1544	900	335	264	133	108	792
	90 / 280M	597	113	457	11.9	766	380	100	1590	900	335	310	133	108	847
	110 / 315S	648	113	508	13.5	858	442	100	1745	1100	251	349	175	143	1050
	132 / 315M	648	113	508	13.5	858	442	100	1800	1100	251	404	175	143	1170
180DR	75 / 280S	597	116	457	11.9	766	380	100	1564	900	343	264	133	108	804
	90 / 280M	597	116	457	11.9	766	380	100	1610	900	343	310	133	108	859
	110 / 315S	648	116	508	13.5	858	442	100	1765	1100	259	349	175	143	1095
	132 / 315M	648	116	508	13.5	858	442	100	1820	1100	259	404	175	143	1185
	160 / 315L	648	116	508	13.5	858	442	100	1900	1100	259	484	175	143	1310
250DR	200 / 315L	648	116	508	13.5	936	442	100	2005	1100	279	569	175	143	1660
	110 / 315S	648	144	508	13.5	858	442	133	1845	1100	341	349	175	143	1180
	132 / 315M	648	144	508	13.5	858	442	133	1900	1100	341	404	175	143	1270
	160 / 315L	648	144	508	13.5	858	442	133	1980	1100	341	484	175	143	1405
	200 / 315L	648	144	508	13.5	936	442	133	2065	1100	341	569	175	143	1695
355DRG	250 / 355M	648	144	508	13.5	936	442	133	2185	1100	391	639	175	143	1905
	160 / 315L	648	144	508	13.5	858	442	133	2009	1100	354	484	175	143	1420
	200 / 315L	648	144	508	13.5	936	442	133	2094	1100	354	569	175	143	1715
	250 / 355M	648	144	508	13.5	936	442	133	2214	1100	404	639	175	143	1895
500DR	315 / 355L	648	144	508	13.5	936	442	133	2374	1100	444	759	175	143	2135
	200 / 315L	648	180	508	13.5	936	442	190	2215	1100	467	569	175	143	1880
	250 / 355M	648	180	508	13.5	936	442	190	2335	1100	517	639	175	143	2055
	315 / 355L	648	180	508	13.5	936	442	190	2455	1100	517	759	175	143	2235

¹⁾ -15 or -20

Device dimensions: Type ABAPG-A4VSO 71DR – 500DR SIEMENS

(dimensions in mm)

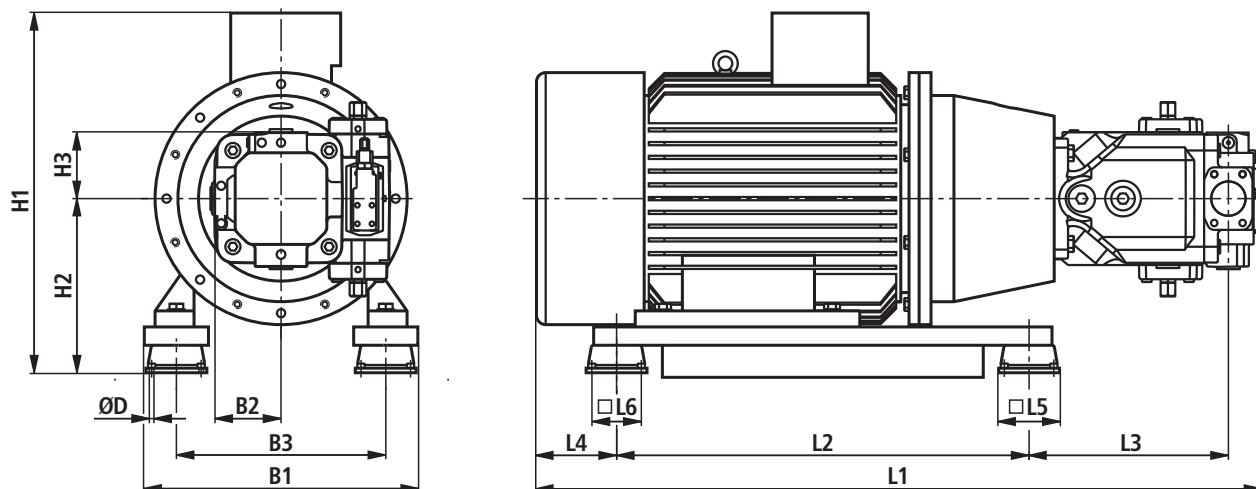
**ABAPG-A4VSO with motor supplier SIEMENS**

Pump A4VSO...	Electric motor kW / frame size	Dimensions													Weight [kg]
		B1	B2	B3	ØD	H1	H2	H3	L1	L2	L3	L4	L5	L6	
71DR	75 / 280S	597	92.5	457	11.9	812	380	85	1520	900	279	300	133	108	767
125DR	75 / 280S	597	113	457	11.9	812	380	100	1580	900	335	300	133	108	810
	90 / 280M	597	113	457	11.9	812	380	100	1690	900	335	410	133	108	882
	110 / 315S	648	113	508	13.5	942	442	100	1767	1100	251	371	175	143	1040
	132 / 315M	648	113	508	13.5	942	442	100	1927	1100	251	531	175	143	1190
180DR	75 / 280S	597	116	457	11.9	812	380	100	1600	900	343	300	133	108	822
	90 / 280M	597	116	457	11.9	812	380	100	1710	900	343	410	133	108	894
	110 / 315S	648	116	508	13.5	942	442	100	1787	1100	259	371	175	143	1085
	132 / 315M	648	116	508	13.5	942	442	100	1947	1100	259	531	175	143	1205
	160 / 315L	648	116	508	13.5	942	442	100	1967	1100	329	481	175	143	1340
250DR	110 / 315S	648	144	508	13.5	942	442	133	1867	1100	341	371	175	143	1170
	132 / 315M	648	144	508	13.5	942	442	133	2027	1100	341	531	175	143	1290
	160 / 315L	648	144	508	13.5	942	442	133	2027	1100	391	481	175	143	1380
	250 / 355M	648	144	508	13.5	942	442	133	2167	1100	391	621	175	143	1725
355DRG	160 / 315L	648	144	508	13.5	942	442	133	2056	1100	404	481	175	143	1395
	250 / 355M	648	144	508	13.5	942	442	133	2196	1100	404	621	175	143	1715
	315 / 355L	648	144	508	13.5	942	442	133	2236	1100	444	621	175	143	1985
500DR	250 / 355M	648	180	508	13.5	942	442	190	2317	1100	517	621	175	143	1875
	315 / 355L	648	180	508	13.5	942	442	190	2317	1100	517	621	175	143	2085

Line connections

Pump type	Line connections			
	Pressure connection B	Suction port S	Leakage oil connection L / L1	Pilot oil port X
A4VSO40	DIN ISO 6162-2 - 3/4" ²⁾	DIN ISO 6162-1 - 1 1/2" ¹⁾	DIN 3852-1 - M22X1.5	-
A4VSO71	DIN ISO 6162-2 - 1" ²⁾	DIN ISO 6162-1 - 2" ¹⁾	DIN 3852-1 - M27X2	-
A4VSO125	DIN ISO 6162-2 - 1 1/4" ²⁾	DIN ISO 6162-1 - 2 1/2" ¹⁾	DIN 3852-1 - M33X2	-
A4VSO180	DIN ISO 6162-2 - 1 1/4" ²⁾	DIN ISO 6162-1 - 3" ¹⁾	DIN 3852-1 - M33X2	-
A4VSO250	DIN ISO 6162-2 - 1 1/2" ²⁾	DIN ISO 6162-1 - 3" ¹⁾	DIN 3852-1 - M42X2	DIN 3852-1 - M14x1.5
A4VSO355	DIN ISO 6162-2 - 1 1/2" ²⁾	DIN ISO 6162-1 - 4" ¹⁾	DIN 3852-1 - M42X2	DIN 3852-1 - M14x1.5
A4VSO500	DIN ISO 6162-2 - 2" ²⁾	DIN ISO 6162-1 - 5" ¹⁾	DIN 3852-1 - M48X2	DIN 3852-1 - M14x1.5

¹⁾ Standard pressure SAE flange figure with metric mounting screws

²⁾ High pressure SAE flange figure with metric mounting screws

Optional accessories at the pressure connection

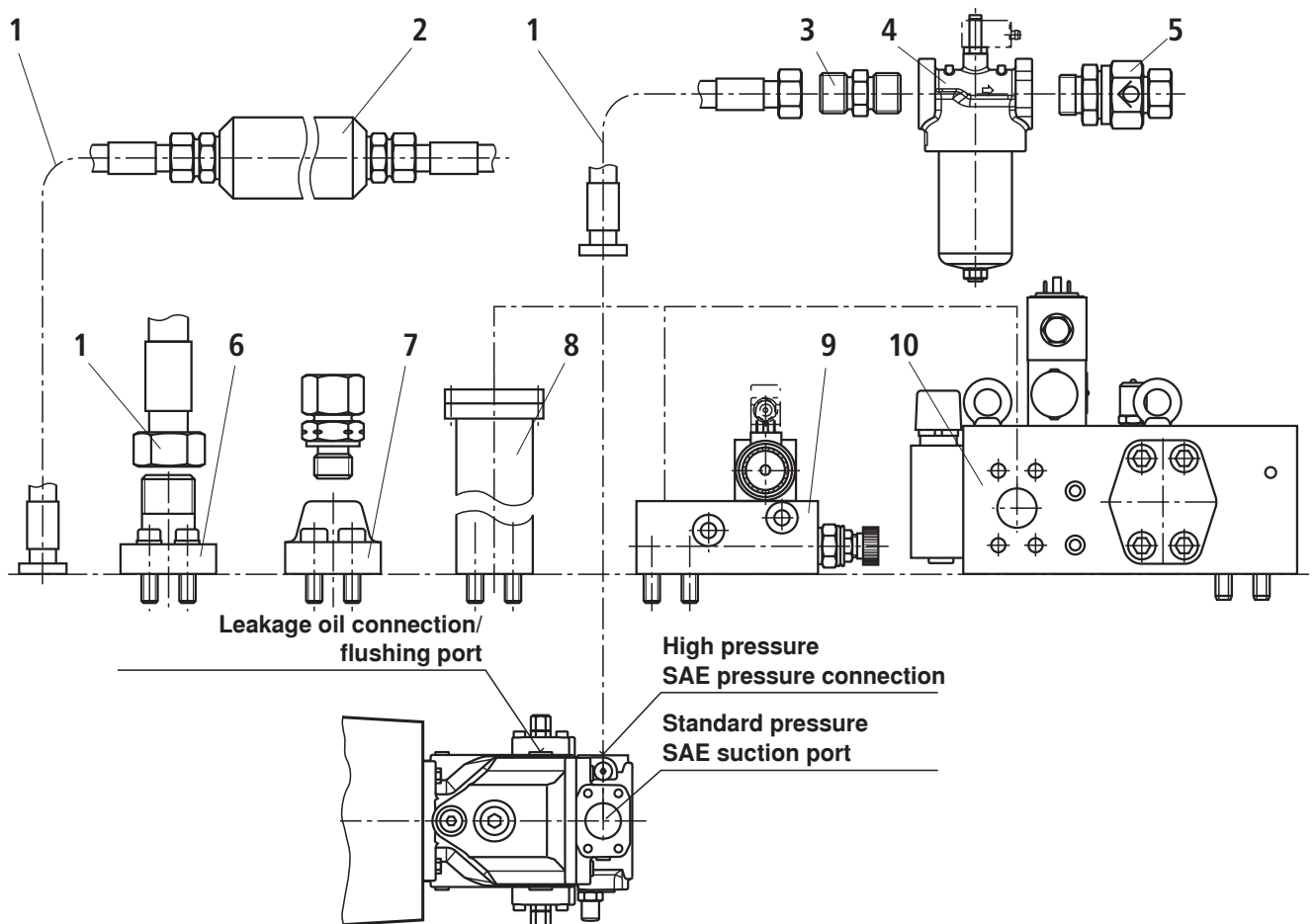

1 Hose line AB 02314, AB 02316

2 Shock and vibration absorber data sheet 29253

3 Fitting ZN 11001-11-AN1 to A4VSO71

4 Inline filter data sheet 51422

5 Check valve AB 02112 to A4VSO71

6 SAE flange high pressure AB 02214

7 SAE flange high pressure AB 02213

8 Shock and vibration absorber data sheet 50142 to A4VSO250

9 Pump safety block data sheet 25891 to A4VSO180

10 Pump manifold block data sheet 62300 to A4VSO355

Items 1 to 10 as optional accessories upon request

Optional accessories at the suction port and leakage oil connection

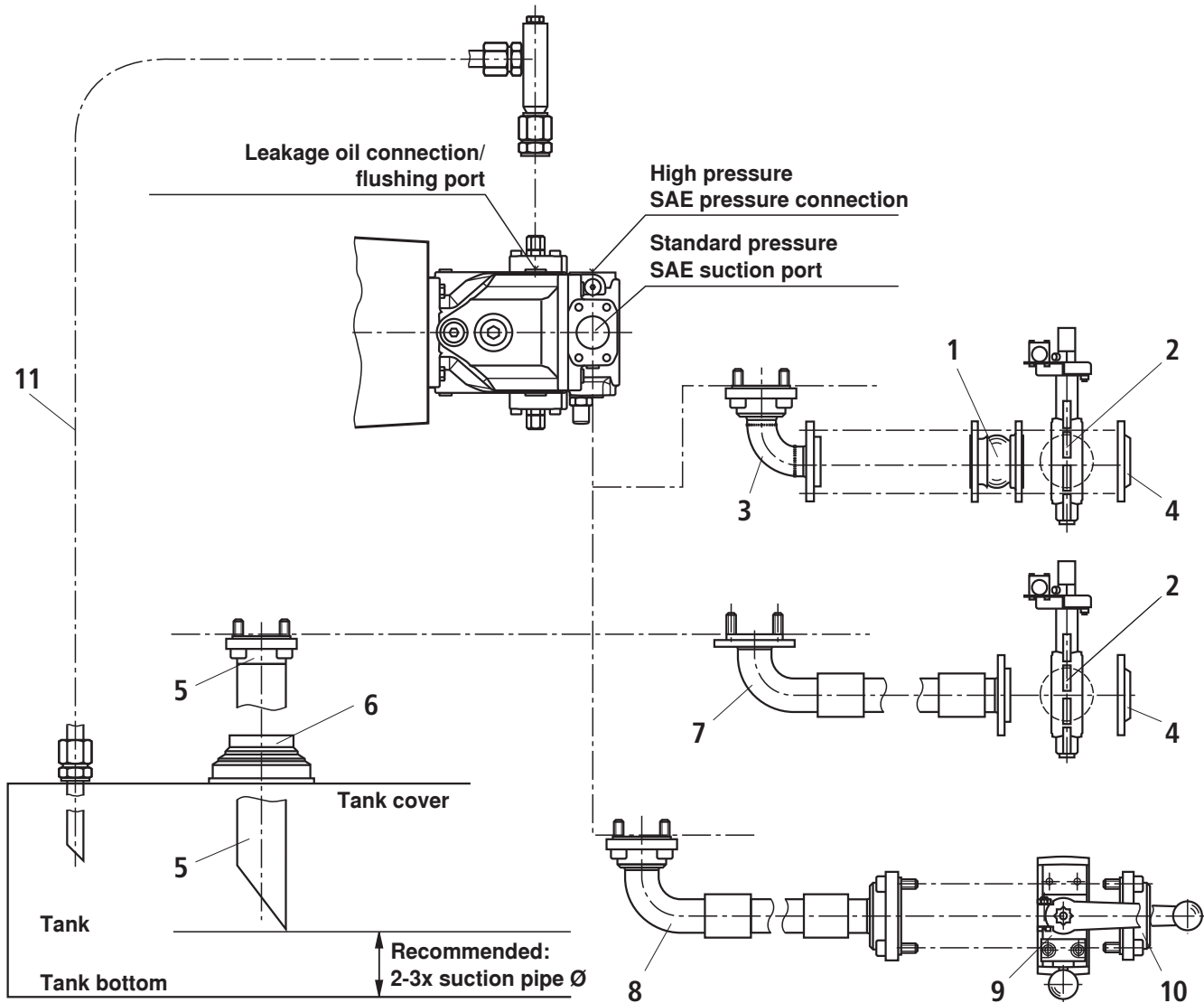

- 1 Compensator DIN AB 02231
- 2 Shut-off valve DIN AB 02129
- 3 Flange bend SAE-DIN AB 02229
- 4 DIN flange AB 02204
- 5 Suction pipe AB 02303
- 6 Elastic pipe fitting AB 01203
- 7 Suction tube SAE-DIN AB 02315

- 8 Suction tube SAE-SAE AB 02315
- 9 Shut-off valve SAE (on request)
- 10 SAE flange AB 02215
- 11 Drain line

Items 1 to 11 as optional accessories upon request

Optional accessories for damping bearing AB33-11

Accessories: Plate

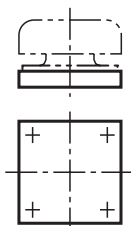

Weld-on plate

Accessories: Clip

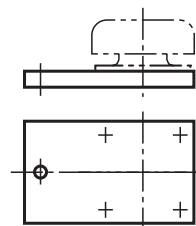

Clip for foundation installation

Installation information

Fluid tank

- Adjust useful volume of the tank to the operating conditions.
- The admissible fluid temperature must not be exceeded; use coolers, if necessary.
- Suction and return line are to be designed so that the largest distance possible between these two lines is guaranteed. Return fluid must not be directly sucked in again.
- The return flow exit must always be below the oil level.

Lines and connections

- Observe all instructions regarding pipe laying dependent on the installation position of the motor-pump group in the hydraulic system according to 92050-01-B.
- Ensure that the pump housing is completely filled with hydraulic fluid during commissioning and operation.
- Remove the protective plug at the pump.
- Select the clear width of the pipes according to the connections (suction speed 0.8 m/s).
- Pipelines and fittings must be carefully cleaned before assembly. Observe the installation information of the manufacturers.
- Connections between pump and further hydraulic systems must be elastic.
- Ensure tight assembly of the pipelines.
- Observe admissible leakage pressure.

Installation position

- Horizontal according to the dimensional drawing. Deviating designs only after coordination with the manufacturer.
- Exclusive use in stationary systems.

Filtration of the hydraulic fluid

- Use return flow and/or pressure filters.
- The finer the filtration, the better the achieved cleanliness class of the hydraulic fluid, the longer the life cycle of the axial piston unit.
- In order to guarantee functional safety of the axial piston unit, at least cleanliness class 20/18/15 in accordance with ISO 4406 is necessary for the hydraulic fluid.

Hydraulic fluid

- Please observe the instructions according to data sheets 90220 and 90221.
- Brand-name hydraulic oils are recommended. In order to guarantee functional safety, at least cleanliness class 20/18/15 in accordance with ISO 4406 is necessary.
- Different oil types must not be mixed as this might result in degradation and deterioration of the lubricity.
- We recommend checking the hydraulic fluid at regular intervals by means of an oil analysis. The measures resulting therefrom are to be implemented.

Commissioning, maintenance and operating instructions

In this connection, please observe the instructions contained in the following documents:

- Data sheet 07009
- Data sheet 07009-MON
- Data sheet 92050
- Data sheet 92050-01-B

Legal provisions

- In Germany, the Ordinance on Industrial Safety and Health (BetrSichV) applies.
- The EU Regulation 640/2009 on the environmentally friendly design of electric motors.

Notice pursuant to the EC Machinery Directive 2006/42/EC, according to annex II part 1, section A, manufacturer's declaration:

- The assemblies were manufactured in accordance with the harmonized standards DIN EN ISO 4413, DIN EN ISO 12100 and DIN EN 60204-1.
- The commissioning is prohibited until it was confirmed that the machine into which the assemblies are to be integrated complies with the regulations laid down in the EC Directives.

Notes

Notes

Bosch Rexroth AG
Hydraulics
Zum Eisengießer 1
97816 Lohr am Main, Germany
Phone +49 (0) 93 52 / 18-0
documentation@boschrexroth.de
www.boschrexroth.de

© This document, as well as the data, specifications and other information set forth in it, are the exclusive property of Bosch Rexroth AG. It may not be reproduced or given to third parties without its consent. The data specified above only serve to describe the product. No statements concerning a certain condition or suitability for a certain application can be derived from our information. The information given does not release the user from the obligation of own judgment and verification. It must be remembered that our products are subject to a natural process of wear and aging.

Notes
